



- C - 526 | Top Clamp Toolholders (C)
- C - 541 | Dimple Lock Toolholders (D)
- C - 547 | Wedge Clamp (M) & Double Lock (M-K) Toolholders
- C - 562 | Lever Lock Toolholders (P)
- C - 585 | Center Screw Toolholders (S)

EXTERNAL TURNING



TURNING

Insert selection

Overview

Negative inserts

Positive inserts

PCBN & PCD inserts

Heavy turning

External Toolholders

Internal Toolholders

Automatic Lathes

Spare Parts

Technical Data

CLAMPING SYSTEMS FOR EXTERNAL TOOLHOLDERS

Sistemas De Fixação Para Ferramentas De Torneamento Externo | Sistemas De Fijación Para Herramientas De Torneado Exterior

(C) TOP CLAMP SYSTEM

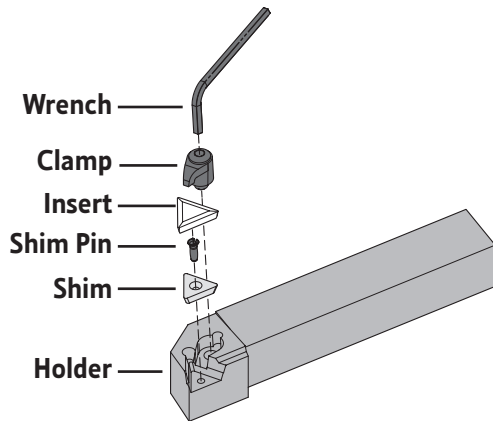

(D) DIMPLE LOCK SYSTEM

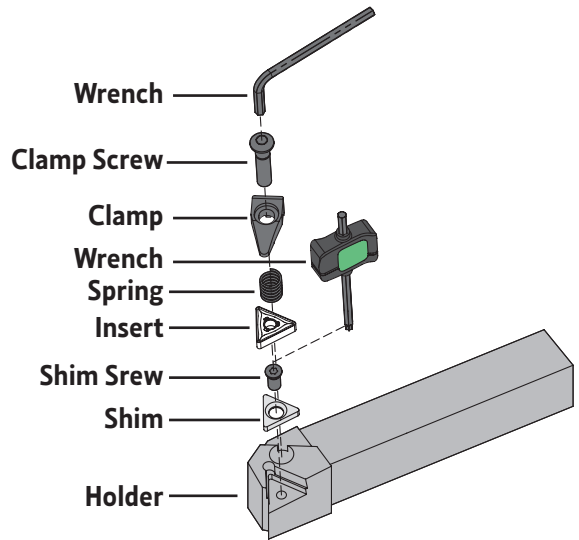

(M) WEDGE CLAMP SYSTEM

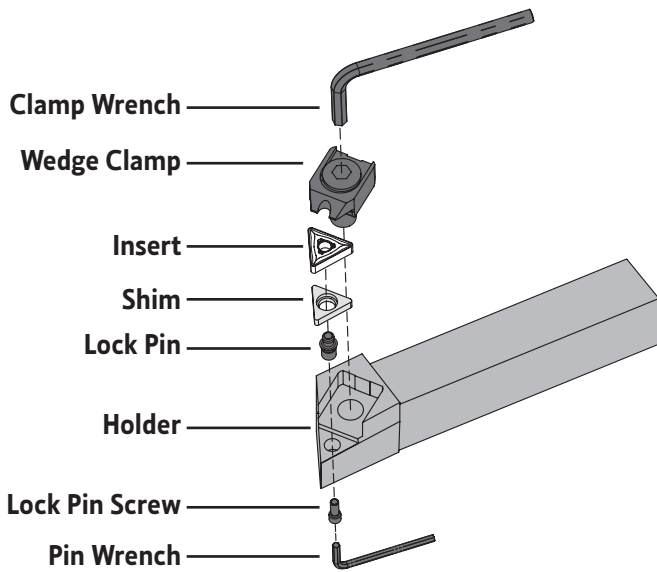

(M-K) DOUBLE LOCK SYSTEM

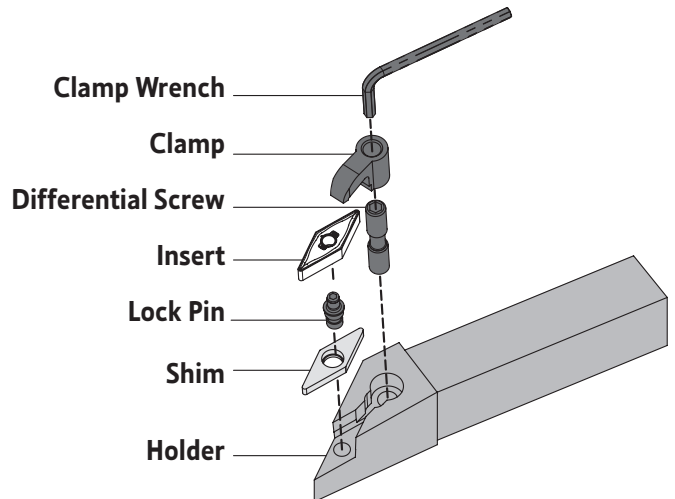

(P) LEVER LOCK SYSTEM

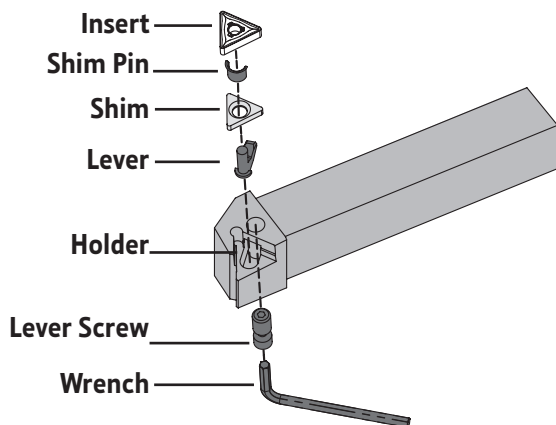

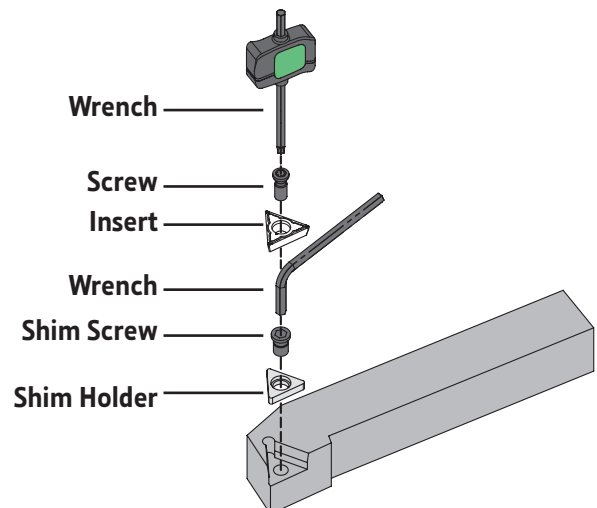

(S) CENTER SCREW SYSTEM



TURNING
 Insert selection
 Overview
 Negative inserts
 Positive inserts
 PCBN & PCD inserts
 Heavy turning
 External Toolholders
 Internal Toolholders
 Automatic Lathes
 Spare Parts
 Technical Data

SUITABLE CLAMPING SYSTEM DEFINITION

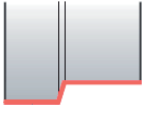
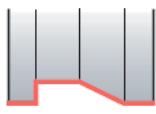
Definição do sistema de fixação | Definición del sistema de Fijación

Operation		Longitudinal turning	Profiling	Facing	Plunging
					
Negative inserts	(C) TOP CLAMP SYSTEM	●	●	●	●
	(D) DIMPLE LOCK SYSTEM	● ●	● ●	● ●	
	(M) WEDGE CLAMP SYSTEM = (M-K) DOUBLE LOCK SYSTEM	●	●	●	
	(P) LEVER LOCK SYSTEM	●	●	●	
Positive inserts	(C) TOP CLAMP SYSTEM	●	●	●	●
	(P) LEVER LOCK SYSTEM		●		
	(S) CENTER SCREW SYSTEM	● ●	● ●	● ●	

● ● Recommended Insert Shape ● Alternative Insert Shape

(D) DIMPLE LOCK SYSTEM

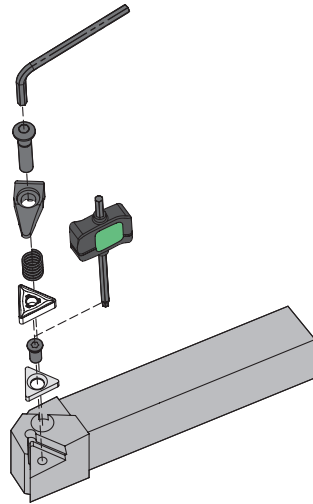

Positive inserts	Negative inserts	Overview	Insert selection	TURNING
<p>DCLN 95°</p> <p>PAGE C - 542 CN.. 1204.. CN.. 1906..</p>	<p>DDJN 93°</p> <p>PAGE C - 543 DN.. 1104.. DN.. 1506..</p>	<p>DSSN 45°</p> <p>PAGE C - 544 SN.. 1204.. SN.. 1906..</p>	<p>DTGN 90°</p> <p>PAGE C - 545 TN.. 1604.. TN.. 2204..</p>	<p>DWLN 95°</p> <p>PAGE C - 546 WN.. 0604.. WN.. 0804..</p>

(M) WEDGE CLAMP SYSTEM

(M-K) DOUBLE LOCK SYSTEM

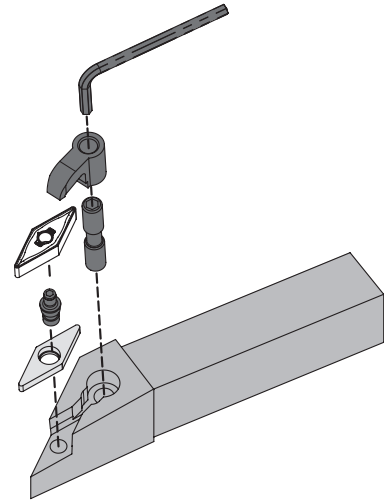
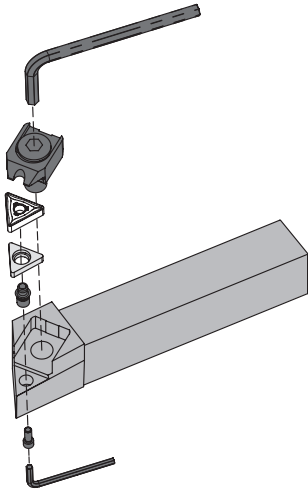

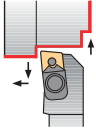
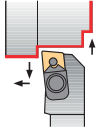
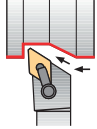
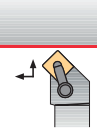
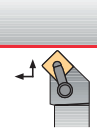
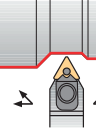
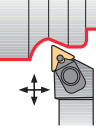
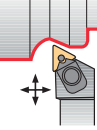
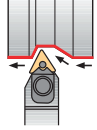
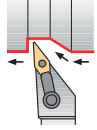
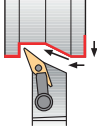
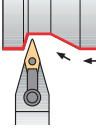
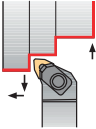
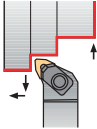
<p>MCLN 95°</p>  <p>PAGE C - 548 CN.. 1204.. CN.. 1906..</p>	<p>MCLN-K 95°</p>  <p>PAGE C - 549 CN.. 1204.. CN.. 1906..</p>	<p>MDJN-K 93°</p>  <p>PAGE C - 550 DN.. 1506..</p>	<p>MSSN-K 45°</p>  <p>PAGE C - 551 SN.. 1204..</p>	<p>MSSN 45°</p>  <p>PAGE C - 552 SN.. 1204.. SN.. 1906..</p>	<p>MTEN 60°</p>  <p>PAGE C - 553 TN.. 1604.. TN.. 2204..</p>
<p>MTJN 93°</p>  <p>PAGE C - 554 TN.. 1604.. TN.. 2204..</p>	<p>MTJN-K 93°</p>  <p>PAGE C - 555 TN.. 1604.. TN.. 2204..</p>	<p>MTNN 63°</p>  <p>PAGE C - 556 TN.. 1604.. TN.. 2204..</p>	<p>MVJN-K 93°</p>  <p>PAGE C - 557 VN.. 1604..</p>	<p>MVQN-K 117°30'</p>  <p>PAGE C - 558 VN.. 1604..</p>	<p>MVVN-K 72°30'</p>  <p>PAGE C - 559 VN.. 1604..</p>
<p>MWLN 95°</p>  <p>PAGE C - 560 WN.. 0604.. WN.. 0804..</p>	<p>MWLN-K 95°</p>  <p>PAGE C - 561 WN.. 0804..</p>				

(P) LEVER LOCK SYSTEM

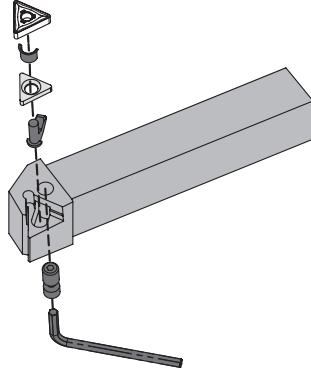

<p>PCBN 75°</p> <p>PAGE C - 563 CN.. 1204.. CN.. 1606.. CN.. 1906.. CN..2509..</p>	<p>PCFN 90°</p> <p>PAGE C - 564 CN.. 1204.. CN.. 1606.. CN.. 1906..</p>	<p>PCKN 75°</p> <p>PAGE C - 565 CN.. 1204... CN.. 1906.. CN.. 2506..</p>	<p>PCLN 95°</p> <p>PAGE C - 566 CN..0903.. ... CN..2509..</p>	<p>PCMN 50°</p> <p>PAGE C - 568 SN.. 1204.. SN.. 1906..</p>	<p>PCSN 45°</p> <p>PAGE C - 569 CN.. 1204.. CN.. 1606.. CN.. 1906..</p>
<p>PDJN 93°</p> <p>PAGE C - 570 DN.. 1104.. DN.. 1504.. DN.. 1506..</p>	<p>PDNN 63°</p> <p>PAGE C - 571 DN.. 1504.. DN.. 1506..</p>	<p>PRDC</p> <p>PAGE C - 572 RC.. 1003M0 ... RC.. 3209M0</p>	<p>PRSC</p> <p>PAGE C - 574 RC.. 10..32</p>	<p>PRSN</p> <p>PAGE C - 575 RN.. 09..25</p>	<p>PSBN 75°</p> <p>PAGE C - 576 SN.. 0903.. ... SN.. 2507..</p>
<p>PSDN 45°</p> <p>PAGE C - 577 SN.. 0903.. ... SN.. 2507..</p>	<p>PSKN 75°</p> <p>PAGE C - 578 SN.. 0903.. ... SN.. 2507..</p>	<p>PSSN 45°</p> <p>PAGE C - 579 SN.. 0903.. ... SN.. 2507..</p>	<p>PTDN 45°</p> <p>PAGE C - 580 TN.. 2204..</p>	<p>PTFN 90°</p> <p>PAGE C - 581 TN.. 1604.. TN.. 2204.. TN.. 2706..</p>	<p>PTGN 90°</p> <p>PAGE C - 582 TN.. 1604.. ... TN.. 3307..</p>
<p>PTTN 60°</p> <p>PAGE C - 583 TN.. 1604.. TN.. 2204..</p>	<p>PWLN 95°</p> <p>PAGE C - 584 WN.. 0604.. WN.. 0804..</p>				

(S) CENTER SCREW SYSTEM

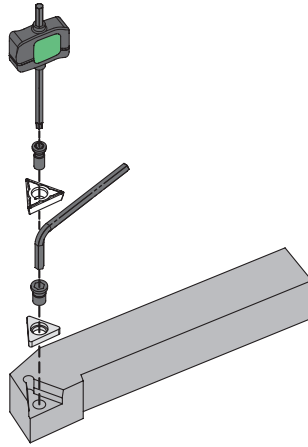

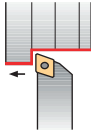
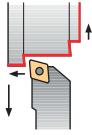
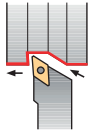
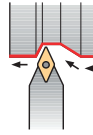
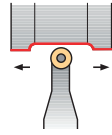
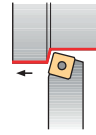
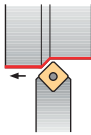
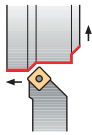
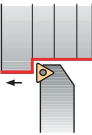
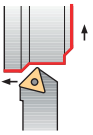
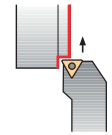
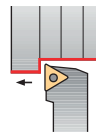
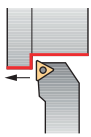
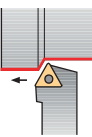
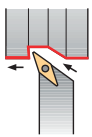
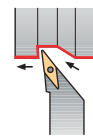
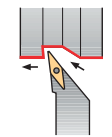
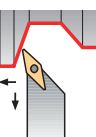
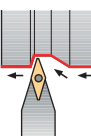
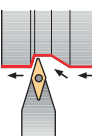
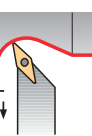
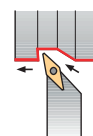
<p>SCAC 90°</p>  <p>PAGE C - 586 CC.. 0602.. CC.. 09T3.. CC.. 1204..</p>	<p>SCLC 95°</p>  <p>PAGE C - 587 CC.. 0602.. CC.. 09T3.. CC.. 1204..</p>	<p>SDJC 93°</p>  <p>PAGE C - 588 DC.. 0702.. DC.. 11T3..</p>	<p>SDNC 62°30'</p>  <p>PAGE C - 589 DC.. 0702.. DC.. 11T3..</p>	<p>SRDC</p>  <p>PAGE C - 590 RC.. 0602M0.. ... RC.. 1204M0..</p>	<p>SSBC 75°</p>  <p>PAGE C - 591 SC.. 09T3.. SC.. 1204..</p>
<p>SSDC 45°</p>  <p>PAGE C - 592 SC.. 09T3.. SC.. 1204..</p>	<p>SSSC 45°</p>  <p>PAGE C - 593 SC.. 09T3.. SC.. 1204..</p>	<p>STAC 90°</p>  <p>PAGE C - 594 TC.. 0902.. TC.. 1102.. TC.. 16T3..</p>	<p>STDC 45°</p>  <p>PAGE C - 595 TC.. 0902.. TC.. 1102.. TC.. 16T3..</p>	<p>STFC 90°</p>  <p>PAGE C - 596 TC.. 0902.. TC.. 1102.. TC.. 16T3..</p>	<p>STGC 90°</p>  <p>PAGE C - 597 TC.. 0902.. TC.. 1102.. TC.. 16T3..</p>
<p>STJC 93°</p>  <p>PAGE C - 598 TC.. 0902.. TC.. 1102.. TC.. 16T3..</p>	<p>STTC 60°</p>  <p>PAGE C - 599 TC.. 0902.. TC.. 1102.. TC.. 16T3..</p>	<p>SVHC 107°30'</p>  <p>PAGE C - 600 VC.. 1604..</p>	<p>SVJB 93°</p>  <p>PAGE C - 601 VB.. 1604..</p>	<p>SVJC 93°</p>  <p>PAGE C - 602 VC.. 1103.. VC.. 1604..</p>	<p>SVLC 95°</p>  <p>PAGE C - 603 VC.. 1303..</p>
<p>SVVB 72°30'</p>  <p>PAGE C - 604 VB.. 1604..</p>	<p>SVVC 72°30'</p>  <p>PAGE C - 605 VC.. 1103.. VC.. 1604..</p>	<p>SVXC 113°</p>  <p>PAGE C - 606 VC.. 1803..</p>	<p>SVZC 100°</p>  <p>PAGE C - 607 VC.. 1604..</p>		



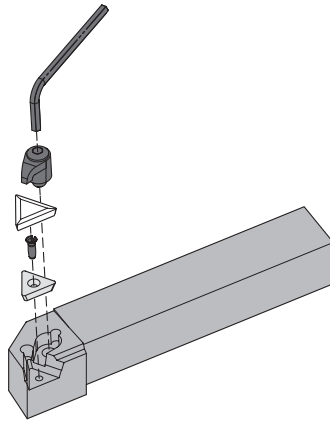





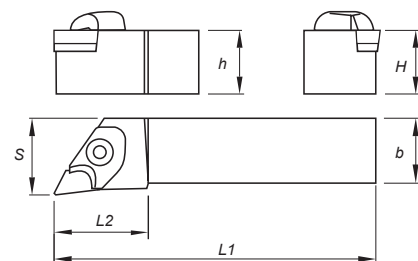
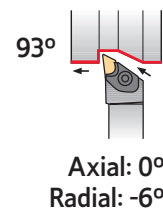
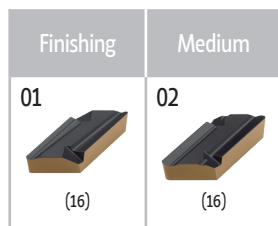

(C) TOP CLAMP SYSTEM



<p>CKJN 93°</p> <p>PAGE C - 527 KNUX 1604..</p>	<p>CKNN 63°</p> <p>PAGE C - 528 KNUX 1604..</p>	<p>CSBP 75°</p> <p>PAGE C - 529 SP. 0903.. SP. 1203.. SP. 1904..</p>	<p>CSDP 45°</p> <p>PAGE C - 530 SP. 0903.. SP. 1203..</p>	<p>CSKP 75°</p> <p>PAGE C - 531 SP. 0903.. SP. 1203.. SP. 1904..</p>	<p>CSSP 45°</p> <p>PAGE C - 532 SP. 0903.. SP. 1203.. SP. 1904..</p>
<p>CSTP 60°</p> <p>PAGE C - 533 SP.0903.. SP.1203..</p>	<p>CTBP 75°</p> <p>PAGE C - 534 TP. 1103.. TP. 1603.. TP. 2204..</p>	<p>CTCP N 90°</p> <p>PAGE C - 535 TP. 1103.. TP. 1603.. TP. 2204..</p>	<p>CTCP 90°</p> <p>PAGE C - 536 TP. 1103.. TP. 1603.. TP. 2204..</p>	<p>CTDP 45°</p> <p>PAGE C - 537 TP. 1103.. TP. 1603.. TP. 2204..</p>	<p>CTFP 90°</p> <p>PAGE C - 538 TP. 1103.. TP. 1603.. TP. 2204..</p>
<p>CTGP 90°</p> <p>PAGE C - 539 TP. 1103.. TP. 1603.. TP. 2204..</p>	<p>CTTP 60°</p> <p>PAGE C - 540 TP. 0902.. TP. 1103.. TP. 2204..</p>				

(C) TOP CLAMP TOOLHOLDERS









































































Order Code		Reference	Dimensions (mm)					Insert	Kg	Stock	
R	L		H=h	b	L1	L2	S			R	L
212034800	212034900	CKJN R/L 2020 K16	20	20	125	34	30	KNUX 1604..	0,390		
212026300	212035000	CKJN R/L 2525 M16	25	25	150	34	32	KNUX 1604..	0,700		
212010300	212260400	CKJN R/L 3225 P16	32	25	170	34	32	KNUX 1604..	1,000		
212260500	212260600	CKJN R/L 3232 P16	32	32	170	34	40	KNUX 1604..	1,250		
212260700	212260800	CKJN R/L 4025 R16	40	25	200	34	32	KNUX 1604..	1,500		

 Stock Items | Itens de stock





 Available under request | Disponível sob consulta | Disponible bajo consulta

SPARE PARTS || Complementos | Repuestos

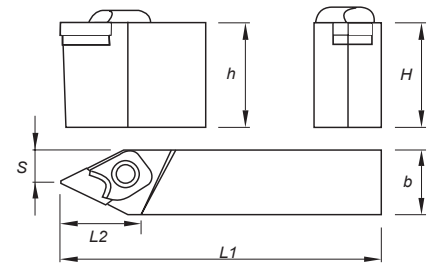
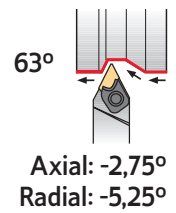
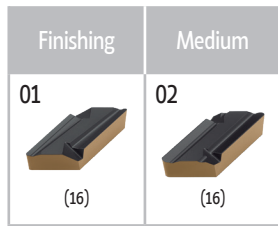
Cutter Reference	Order separately						
	Shim	Shim Pin	Shim Pin Punch	Spring	Clamp	Screw	Wrench
CKJN R 2020 K16	 CK160500	 BE03000	 BF04813	 M09513	 GAW1400	 DW142600	 SS40
CKJN R 2525 M16	 CK160500	 BE03000	 BF04815	 M09513	 GAW1400	 DW142600	 SS40
CKJN R 3225 P16	 CK160500	 BE03000	 BF04815	 M09513	 GAW1400	 DW142600	 SS40
CKJN R 3232 P16	 CK160500	 BE03000	 BF04815	 M09513	 GAW1400	 DW142600	 SS40
CKJN R 4025 R16	 CK160500	 BE03000	 BF04815	 M09513	 GAW1400	 DW142600	 SS40
CKJN L 2020 K16	 CK160501	 BE03000	 BF04813	 M09513	 GAW1401	 DW142600	 SS40
CKJN L 2525 M16	 CK160501	 BE03000	 BF04815	 M09513	 GAW1401	 DW142600	 SS40
CKJN L 3225 P16	 CK160501	 BE03000	 BF04815	 M09513	 GAW1401	 DW142600	 SS40
CKJN L 3232 P16	 CK160501	 BE03000	 BF04815	 M09513	 GAW1401	 DW142600	 SS40
CKJN L 4025 R16	 CK160501	 BE03000	 BF04815	 M09513	 GAW1401	 DW142600	 SS40

(C) TOP CLAMP TOOLHOLDERS









Order Code		Reference	Dimensions (mm)					Insert	Kg	Stock	
R	L		H-h	b	L1	L2	S			R	L
212260900	212261000	CKNN R/L 4025 R16	40	25	200	37	14,3	KNUX 1604..	1,500		
212261100	212261200	CKNN R/L 5032 S16	50	32	250	37	16,8	KNUX 1604..	3,000		



 Stock Items | Itens de stock

Available under request | Disponível sob consulta | Disponible bajo consulta









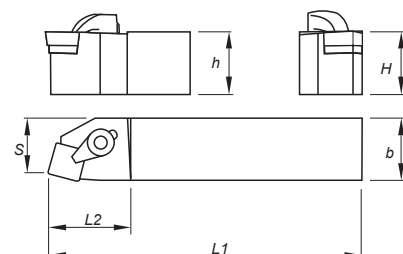
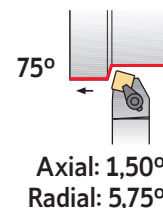









SPARE PARTS || Complementos | Repuestos

Cutter Reference	Order separately						
	Shim	Shim Pin	Shim Pin Punch	Spring	Clamp	Screw	Wrench
CKNN R 4025 R16							
CKNN R 5032 S16	CK160500	BE03000	BF04815	M09513	GAW1400	DW142600	SS40
CKNN L 4025 R16	CK160501	BE03000	BF04815	M09513	GAW1401	DW142600	SS40
CKNN L 5032 S16	CK160501	BE03000	BF04815	M09513	GAW1401	DW142600	SS40

(C) TOP CLAMP TOOLHOLDERS

Medium to Finishing	Finishing to Fine Finishing	Medium
Flat  (09-12-19)	12  (09-12)	13  (09-12)









Order Code		Reference	Dimensions (mm)					Insert	Kg	Stock	
R	L		H=h	b	L1	L2	S			R	L
212042000	212261300	CSBP R/L 1212 F09	12	12	80	22	11	SP..0903..	0,070		
212261400	212261500	CSBP R/L 1616 H09	16	16	100	22	13	SP..0903..	0,200		
212261600	212261700	CSBP R/L 2020 K09	20	20	125	22	17	SP..0903..	0,400		
212261800	212033900	CSBP R/L 2020 K12	20	20	125	34	17	SP..1203..	0,400		
212034000	212034100	CSBP R/L 2525 M12	25	25	150	34	22	SP..1203..	0,700		
212261900	212262000	CSBP R/L 3225 P12	32	25	170	34	22	SP..1203..	1,000		
212262100	212262200	CSBP R/L 3232 P19	32	32	170	40	27	SP..1904..	1,250		
212262300	212262400	CSBP R/L 4040 S19	40	40	250	40	35	SP..1904..	3,000		
212262500	212262600	CSBP R/L 5050 T19	50	50	300	40	43	SP..1904..	5,650		

 Stock Items | Itens de stock

 Available under request | Disponível sob consulta | Disponible bajo consulta

SPARE PARTS || Complementos | Repuestos



Complementary Accessories - Flat Inserts

Cutter Reference	Shim	Shim Pin	Clamp	Wrench	Clamp	Chip Breaker 1	Chip Breaker 2
							
CSBP R/L 1212 F09	CS090300	BE02100	GS05001	SS25	GS05004	QCS0900	-
CSBP R/L 1616 H09	CS090300	BE02100	GS05001	SS25	GS05004	QCS0900	-
CSBP R/L 2020 K09	CS090300	BE02100	GS05001	SS25	GS05004	QCS0900	-
CSBP R/L 2020 K12	CS120300	BE02100	GS06000	SS30	GS05005	QCS1200	QCS1201
CSBP R/L 2525 M12	CS120300	BE02100	GS06000	SS30	GS05005	QCS1200	QCS1201
CSBP R/L 3225 P12	CS120300	BE02100	GS06000	SS30	GS05005	QCS1200	QCS1201
CSBP R/L 3232 P19	CS190300	BE03000	GS08000	SS40	GS08001	QCS1900	QCS1901
CSBP R/L 4040 S19	CS190300	BE03000	GS08000	SS40	GS08001	QCS1900	QCS1901
CSBP R/L 5050 T19	CS190300	BE03000	GS08000	SS40	GS08001	QCS1900	QCS1901

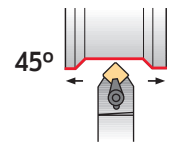







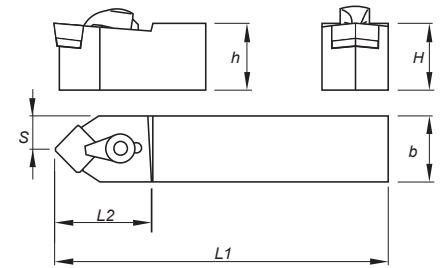





(C) TOP CLAMP TOOLHOLDERS



Axial: 4,25°
Radial: 4,25°

Medium to Finishing	Finishing to Fine Finishing	Medium
Flat  (09-12)	12  (09-12)	13  (09-12)









Order Code		Reference	Dimensions (mm)					Insert	Kg	Stock	
R	L		H=h	b	L1	L2	S			R	L
212262700	212262800	CSDP R/L 1010 E09	10	10	70	22	5,6	SP.. 0903..	0,030		
212262900	212263000	CSDP R/L 1212 F09	12	12	80	22	7,6	SP.. 0903..	0,070		
212263100	212263200	CSDP R/L 1616 H09	16	16	100	22	11,6	SP.. 0903..	0,200		
212263300	212263400	CSDP R/L 2020 K12	20	20	125	28	14,0	SP.. 1203..	0,400		
212263500	212263600	CSDP R/L 2525 M12	25	25	150	28	19,0	SP.. 1203..	0,700		
212263700		CSDP N 1010 E09	10	10	70	22	5,0	SP.. 0903..	0,030		
212263800		CSDP N 1212 F09	12	12	80	22	6,0	SP.. 0903..	0,070		
212263900		CSDP N 1616 H09	16	16	100	22	8,0	SP.. 0903..	0,200		
212018400		CSDP N 2020 K12	20	20	125	28	10,0	SP.. 1203..	0,400		
212264000		CSDP N 2525 M12	25	25	150	28	12,5	SP.. 1203..	0,700		

 Stock Items | Itens de stock

 Available under request | Disponível sob consulta | Disponible bajo consulta

SPARE PARTS | Complementos | Repuestos

Complementary Accessories - Flat Inserts

Cutter Reference	Shim 	Shim Pin 	Clamp 	Wrench 	Clamp 	Chip Breaker 1 	Chip Breaker 2 
CSDP R/L 1010 E09	-	-	GS05000	SS25	-	QCS0901	QCS0902
CSDP R/L 1212 F09	CS090300	BE02100	GS05001	SS25	GS05004	QCS0901	QCS0902
CSDP R/L 1616 H09	CS090300	BE02100	GS05001	SS25	GS05004	QCS0901	QCS0902
CSDP R/L 2020 K12	CS120300	BE02100	GS06000	SS30	GS05005	QCS1202	QCS1203
CSDP R/L 2525 M12	CS120300	BE02100	GS06000	SS30	GS05005	QCS1202	QCS1203
CSDP N 1010 E09	-	-	GS05000	SS25	-	QCS0901	QCS0902
CSDP N 1212 F09	CS090300	BE02100	GS05001	SS25	GS05004	QCS0901	QCS0902
CSDP N 1616 H09	CS090300	BE02100	GS05001	SS25	GS05004	QCS0901	QCS0902
CSDP N 2020 K12	CS120300	BE02100	GS06000	SS30	GS05005	QCS1202	QCS1203
CSDP N 2525 M12	CS120300	BE02100	GS06000	SS30	GS05005	QCS1202	QCS1203

(C) TOP CLAMP TOOLHOLDERS

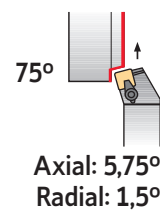

Medium to Finishing	Finishing to Fine Finishing	Medium
Flat (09-12-19)	12 (09-12)	13 (09-12)

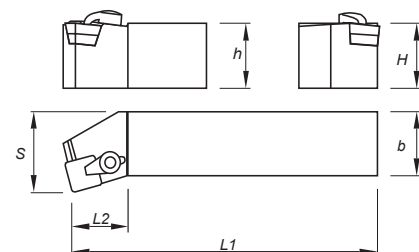

Order Code		Reference	Dimensions (mm)					Insert	Kg	Stock	
R	L		H=h	b	L1	L2	S			R	L
212042100	212264100	CSKP R/L 1212 F09	12	12	80	18	16	SP.0903..	0,070		
212264200	212264300	CSKP R/L 1616 H09	16	16	100	22	20	SP.0903..	0,200		
212264400	212264500	CSKP R/L 2020 K09	20	20	125	22	25	SP.0903..	0,400		
212034200	212034300	CSKP R/L 2020 K12	20	20	125	28	25	SP.1203..	0,400		
212036000	212034400	CSKP R/L 2525 M12	25	25	150	28	32	SP.1203..	0,700		
212264600	212264700	CSKP R/L 3225 P12	32	25	170	28	32	SP.1203..	1,000		
212264800	212264900	CSKP R/L 3232 P19	32	32	170	42	40	SP.1904..	1,250		
212265000	212265100	CSKP R/L 4040 S19	40	40	250	42	50	SP.1904..	3,000		
212265200	212265300	CSKP R/L 5050 T19	50	50	300	42	60	SP.1904..	5,650		

Stock Items | Itens de stock

Available under request | Disponível sob consulta | Disponible bajo consulta

SPARE PARTS || Complementos | Repuestos

Complementary Accessories - Flat Inserts

Cutter Reference	Shim	Shim Pin	Clamp	Wrench	Clamp	Chip Breaker 1	Chip Breaker 2
CSKP R/L 1212 F09	CS090300	BE02100	GS05001	SS25	GS05004	QCS0900	-
CSKP R/L 1616 H09	CS090300	BE02100	GS05001	SS25	GS05004	QCS0900	-
CSKP R/L 2020 K09	CS090300	BE02100	GS05001	SS25	GS05004	QCS0900	-
CSKP R/L 2020 K12	CS120300	BE02100	GS06000	SS30	GS05005	QCS1200	QCS1201
CSKP R/L 2525 M12	CS120300	BE02100	GS06000	SS30	GS05005	QCS1200	QCS1201
CSKP R/L 3225 P12	CS120300	BE02100	GS06000	SS30	GS05005	QCS1200	QCS1201
CSKP R/L 3232 P19	CS190300	BE03000	GS08000	SS40	GS08001	QCS1900	QCS1901
CSKP R/L 4040 S19	CS190300	BE03000	GS08000	SS40	GS08001	QCS1900	QCS1901
CSKP R/L 5050 T19	CS190300	BE03000	GS08000	SS40	GS08001	QCS1900	QCS1901

C
TURNING
Insert selection
Overview
Negative inserts
Positive inserts
PCBN & PCD inserts
Heavy turning
External Toolholders
Internal Toolholders
Automatic Lathes
Spare Parts
Technical Data

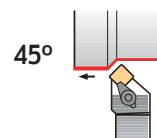

Axial: 4,25°
Radial: 4,25°

Medium to Finishing	Finishing to Fine Finishing	Medium
Flat (09-12-19)	12 (09-12)	13 (09-12)

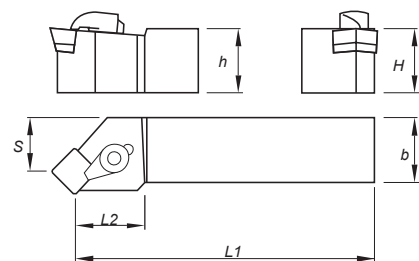



Order Code		Reference	Dimensions (mm)					Insert	Kg	Stock	
R	L		H=h	b	L1	L2	S			R	L
212019000	212018800	CSSP R/L 1212 F09	12	12	80	22	16	SP.. 0903..	0,070		
212265400	212265500	CSSP R/L 1616 H09	16	16	100	22	20	SP.. 0903..	0,200		
212034500	212034600	CSSP R/L 2020 K12	20	20	125	22	25	SP.. 1203..	0,400		
212036100	212034700	CSSP R/L 2525 M12	25	25	150	28	32	SP.. 1203..	0,700		
212265600	212265700	CSSP R/L 3225 P12	32	25	170	28	32	SP.. 1203..	1,000		
212265800	212265900	CSSP R/L 3232 P19	32	32	170	42	40	SP.. 1904..	1,250		
212266000	212266100	CSSP R/L 4040 S19	40	40	250	42	50	SP.. 1904..	3,000		

Stock Items | Itens de stock







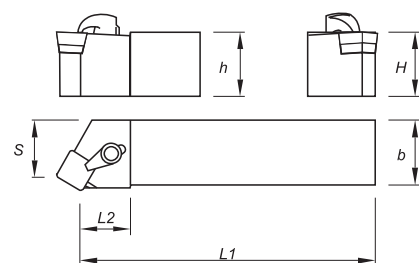
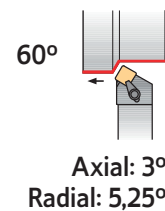

Available under request | Disponivel sob consulta | Disponible bajo consulta

Complementary Accessories - Flat Inserts

Cutter Reference	Shim	Shim Pin	Clamp	Wrench	Clamp	Chip Breaker 1	Chip Breaker 2
CSSP R/L 1212 F09							
CSSP R/L 1616 H09	CS090300	BE02100	GS05001	SS25	GS05004	QCS0901	QCS0902
CSSP R/L 2020 K12	CS120300	BE02100	GS06000	SS30	GS05005	QCS1202	QCS1203
CSSP R/L 2525 M12	CS120300	BE02100	GS06000	SS30	GS05005	QCS1202	QCS1203
CSSP R/L 3225 P12	CS120300	BE02100	GS06000	SS30	GS05005	QCS1202	QCS1203
CSSP R/L 3232 P19	CS190300	BE03000	GS08000	SS40	GS08001	QCS1902	QCS1903
CSSP R/L 4040 S19	CS190300	BE03000	GS08000	SS40	GS08001	QCS1902	QCS1903

Medium to Finishing	Finishing to Fine Finishing	Medium
Flat	12	13
		
(09-12)	(09-12)	(09-12)









Order Code		Reference	Dimensions (mm)					Insert	Kg	Stock	
R	L		H=h	b	L1	L2	S			R	L
212266200	212266300	CSTP R/L 1616 H09	16	16	100	22	13	SP.0903..	0,200		
212266400	212266500	CSTP R/L 2020 K09	20	20	125	22	17	SP.0903..	0,350		
212266600	212266700	CSTP R/L 2020 K12	20	20	125	28	17	SP.1203..	0,400		
212266800	212266900	CSTP R/L 2525 M12	25	25	150	28	22	SP.1203..	0,700		



 Stock Items | Itens de stock

Available under request | Disponível sob consulta | Disponible bajo consulta

Complementary Accessories - Flat Inserts

Cutter Reference	Shim	Shim Pin	Clamp	Wrench	Clamp	Chip Breaker 1	Chip Breaker 2
							
CSTP R/L 1616 H09	CS090300	BE02100	GS05001	SS25	GS05004	QCS0900	-
CSTP R/L 2020 K09	CS090300	BE02100	GS05001	SS25	GS05004	QCS0900	-
CSTP R/L 2020 K12	CS120300	BE02100	GS06000	SS30	GS05005	QCS1200	QCS1201
CSTP R/L 2525 M12	CS120300	BE02100	GS06000	SS30	GS05005	QCS1200	QCS1201





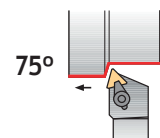

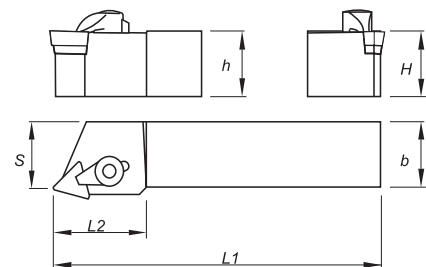

TURNING
Insert selection
Overview
Negative inserts
Positive inserts
PCBN & PCD inserts
Heavy turning
External Toolholders
Internal Toolholders
Automatic Lathes
Spare Parts
Technical Data

Medium to Finishing	Finishing to Fine Finishing	Medium
Flat  (11-16)	12  (11-16)	13  (11-16)



Axial: 1,5°
Radial: 5,75°









Order Code		Reference	Dimensions (mm)					Insert	Kg	Stock	
R	L		H=h	b	L1	L2	S			R	L
212267000	212267100	CTBP R/L 1212 F11	12	12	80	18	11	TP. 1103..	0,070		
212267200	212267300	CTBP R/L 1616 H11	16	16	100	22	13	TP. 1103..	0,200		
212267400	212267500	CTBP R/L 2020 K16	20	20	125	28	17	TP. 1603..	0,400		
212267600	212267700	CTBP R/L 2525 M16	25	25	150	28	22	TP. 1603..	0,700		





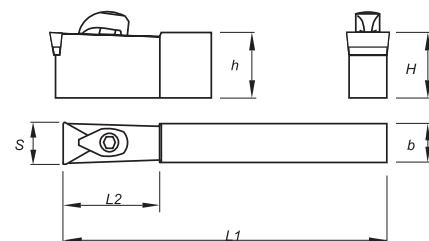
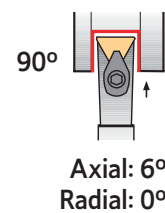
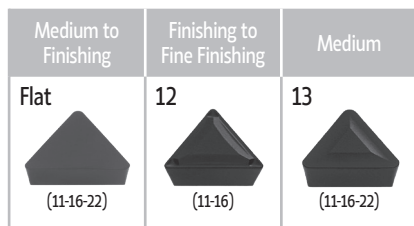

 Stock Items | Itens de stock

 Available under request | Disponível sob consulta | Disponible bajo consulta

Complementary Accessories - Flat Inserts







Cutter Reference	Shim	Shim Pin	Clamp	Wrench	Clamp	Chip Breaker 1	Chip Breaker 2
							
CTBP R/L 1212 F11	-	-	GS05001	SS25	GS05004	QCT1100	-
CTBP R/L 1616 H11	-	-	GS05001	SS25	GS05004	QCT1100	-
CTBP R/L 2020 K16	CT160301	BE02100	GS06000	SS30	GS05005	QCT1600	QCT1601
CTBP R/L 2525 M16	CT160301	BE02100	GS06000	SS30	GS05005	QCT1600	QCT1601



Order Code	Reference	Dimensions (mm)					Insert	Kg	Stock
		H=h	b	L1	L2	S			
212267800	CTCP N 1009 E11	10	9	70	22	11	TP.. 1103..	0,040	
212267900	CTCP N 2009 K11	20	9	125	22	11	TP.. 1103..	0,150	
212268000	CTCP N 2509 R11	25	9	200	22	11	TP.. 1103..	0,350	
212268100	CTCP N 2513 R16	25	13	200	28	16	TP.. 1603..	0,500	
212268200	CTCP N 2518 R22	25	18	200	34	22	TP.. 2204..	0,650	
212268300	CTCP N 4018 R22	40	18	200	34	22	TP.. 2204..	1,100	

 Stock Items | Itens de stock

 Available under request | Disponível sob consulta | Disponible bajo consulta

Cutter Reference	Shim	Shim Pin	Clamp	Wrench	Chip Breaker 1	Chip Breaker 2
						
CTCP N 1009 E11	-	-	GS04000	SS25	QCT1100	QCT1101
CTCP N 2009 K11	-	-	GS04000	SS25	QCT1100	QCT1101
CTCP N 2509 R11	-	-	GS04000	SS25	QCT1100	QCT1101
CTCP N 2513 R16	CT160301	BE02100	GS05002	SS30	QCT1600	QCT1601
CTCP N 2518 R22	CT220301	BE03000	GS08000	SS40	QCT2200	QCT2201
CTCP N 4018 R22	CT220301	BE03000	GS08000	SS40	QCT2200	QCT2201

(C) TOP CLAMP TOOLHOLDERS

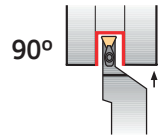

Axial: 6°
Radial: 0°

Medium to Finishing	Finishing to Fine Finishing	Medium
Flat (11-16-22)	12 (11-16)	13 (11-16-22)

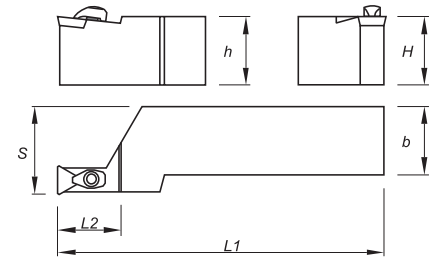

Order Code		Reference	Dimensions (mm)					Insert	Kg	Stock	
R	L		H=h	b	L1	L2	S			R	L
212268400	212268500	CTCP R/L 1212 F11	12	12	80	22	16	TP.. 1103..	0,070		
212268600	212268700	CTCP R/L 1616 H11	16	16	100	22	20	TP.. 1103..	0,200		
212268800	212268900	CTCP R/L 2020 K11	20	20	125	22	25	TP.. 1103..	0,400		
212269000	212269100	CTCP R/L 2525 M11	25	25	150	22	32	TP.. 1103..	0,700		
212269200	212269300	CTCP R/L 3225 P16	32	32	170	28	32	TP.. 1603..	1,000		
212269400	212269500	CTCP R/L 3232 P16	32	32	170	28	40	TP.. 1603..	1,250		
212269600	212269700	CTCP R/L 3225 P22	32	25	170	34	32	TP.. 2204..	1,000		
212269800	212269900	CTCP R/L 3232 P22	32	32	170	34	40	TP.. 2204..	1,250		



Stock Items | Itens de stock

Available under request | Disponível sob consulta | Disponible bajo consulta

SPARE PARTS || Complementos | Repuestos

Cutter Reference	Shim 	Shim Pin 	Clamp 	Wrench 	Chip Breaker 1 	Chip Breaker 2
CTCP R/L 1212 F11	-	-	GS04000	SS25	QCT1100	QCT1101
CTCP R/L 1616 H11	-	-	GS04000	SS25	QCT1100	QCT1101
CTCP R/L 2020 K11	-	-	GS04000	SS25	QCT1100	QCT1101
CTCP R/L 2525 M11	-	-	GS04000	SS25	QCT1100	QCT1101
CTCP R/L 3225 P16	CT160301	BE02100	GS05002	SS30	QCT1600	QCT1601
CTCP R/L 3232 P16	CT160301	BE02100	GS05002	SS30	QCT1600	QCT1601
CTCP R/L 3225 P22	CT220301	BE03000	GS08000	SS40	QCT2200	QCT2201
CTCP R/L 3232 P22	CT220301	BE03000	GS08000	SS40	QCT2200	QCT2201

(C) TOP CLAMP TOOLHOLDERS

Medium to Finishing	Finishing to Fine Finishing	Medium
Flat  (11-16-22)	12  (11-16)	13  (11-16-22)

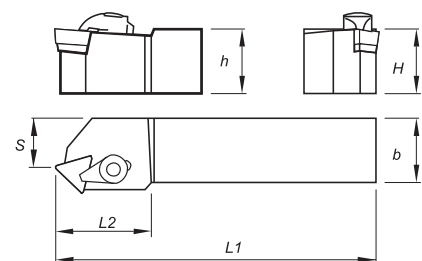
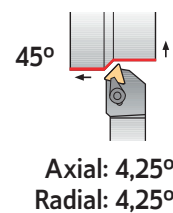

Order Code		Reference	Dimensions (mm)					Insert	Kg	Stock	
R	L		H=h	b	L1	L2	S			R	L
212270000	212270100	CTDP R/L 1212 F11	12	12	80	20	6,3	TP.. 1103..	0,070		
212019400	212270200	CTDP R/L 1616 H11	16	16	100	22	10,3	TP.. 1103..	0,200		
212270300	212270400	CTDP R/L 2020 K16	20	20	125	28	12,2	TP.. 1603..	0,400		
212270500	212019300	CTDP R/L 2525 M16	25	25	150	28	17,2	TP.. 1603..	0,700		
212270600	212270700	CTDP R/L 3232 P16	32	32	170	28	23,5	TP.. 1603..	1,250		
212270800	212270900	CTDP R/L 3232 P22	32	32	170	34	20,5	TP.. 2204..	1,250		



Stock Items | Itens de stock

Available under request | Disponível sob consulta | Disponible bajo consulta

SPARE PARTS | Complementos | Repuestos

Cutter Reference	Complementary Accessories - Flat Inserts						
	Shim	Shim Pin	Clamp	Wrench	Clamp	Chip Breaker 1	Chip Breaker 2
CTDP R/L 1212 F11	-	-	GS05001	SS25	GS05004	QCT1100	QCT1101
CTDP R/L 1616 H11	-	-	GS05001	SS25	GS05004	QCT1100	QCT1101
CTDP R/L 2020 K16	CT160301	BE02100	GS06000	SS30	GS05005	QCT1600	QCT1601
CTDP R/L 2525 M16	CT160301	BE02100	GS06000	SS30	GS05005	QCT1600	QCT1601
CTDP R/L 3232 P16	CT160301	BE02100	GS06000	SS30	GS05005	QCT1600	QCT1601
CTDP R/L 3232 P22	CT220301	BE03000	GS08000	SS40	GS08001	QCT2200	QCT2201





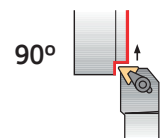



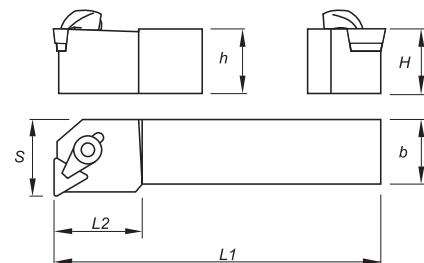

















(C) TOP CLAMP TOOLHOLDERS

Medium to Finishing	Finishing to Fine Finishing	Medium
Flat  (11-16-22)	12  (11-16)	13  (11-16-22)



Axial: 6°
Radial: 0°









Order Code		Reference	Dimensions (mm)					Insert	Kg	Stock	
R	L		H=h	b	L1	L2	S			R	L
212271000	212271100	CTFP R/L 1010 E11	10	10	70	16	12	TP.. 1103..	0,030		
212019800	212271200	CTFP R/L 1212 F11	12	12	80	18	16	TP.. 1103..	0,070		
212019900	212271300	CTFP R/L 1616 H11	16	16	100	22	20	TP.. 1103..	0,200		
212033600	212019500	CTFP R/L 2020 K11	20	20	125	22	25	TP.. 1103..	0,400		
212033700	212024000	CTFP R/L 2020 K16	20	20	125	22	25	TP.. 1603..	0,400		
212035900	212033800	CTFP R/L 2525 M16	25	25	150	22	32	TP.. 1603..	0,700		
212271400	212271500	CTFP R/L 3225 P16	32	25	170	22	32	TP.. 1603..	1,000		
212271600	212271700	CTFP R/L 3232 P16	32	32	170	28	40	TP.. 1603..	1,250		
212271800	212271900	CTFP R/L 4040 S16	40	40	250	34	50	TP.. 1603..	3,000		
212272000	212272100	CTFP R/L 5050 T16	50	50	300	34	60	TP.. 1603..	5,650		
212272200	212272300	CTFP R/L 3232 P22	32	32	170	34	40	TP.. 2204..	1,250		
212272400	212272500	CTFP R/L 4040 S22	40	40	250	34	50	TP.. 2204..	3,000		
212272600	212272700	CTFP R/L 5050 T22	50	50	300	34	60	TP.. 2204..	5,650		

 Stock Items | Itens de stock



 Available under request | Disponivel sob consulta | Disponible bajo consulta

SPARE PARTS | Complementos | Repuestos









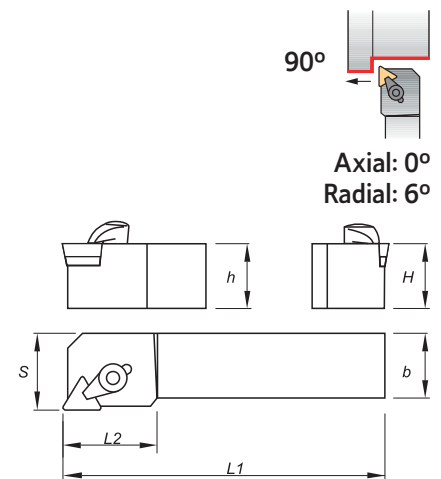











Complementary Accessories - Flat Inserts

Cutter Reference	Shim	Shim Pin	Clamp	Wrench	Clamp	Chip Breaker 1	Chip Breaker 2
							
CTFP R/L 1010 E11	-	-	GS03000	SS15	-	-	-
CTFP R/L 1212 F11	-	-	GS05001	SS25	GS05004	QCT1100	QCT1101
CTFP R/L 1616 H11	-	-	GS05001	SS25	GS05004	QCT1100	QCT1101
CTFP R/L 2020 K11	-	-	GS05001	SS25	GS05004	QCT1100	QCT1101
CTFP R/L 2020 K16	CT160301	BE02100	GS06000	SS30	GS05005	QCT1600	QCT1601
CTFP R/L 2525 M16	CT160301	BE02100	GS06000	SS30	GS05005	QCT1600	QCT1601
CTFP R/L 3225 P16	CT160301	BE02100	GS06000	SS30	GS05005	QCT1600	QCT1601
CTFP R/L 3232 P16	CT160301	BE02100	GS06000	SS30	GS05005	QCT1600	QCT1601
CTFP R/L 4040 S16	CT160301	BE02100	GS06000	SS30	GS05005	QCT1600	QCT1601
CTFP R/L 5050 T16	CT160301	BE02100	GS06000	SS30	GS05005	QCT1600	QCT1601
CTFP R/L 3232 P22	CT220301	BE03000	GS08000	SS40	GS08001	QCT2200	QCT2201
CTFP R/L 4040 S22	CT220301	BE03000	GS08000	SS40	GS08001	QCT2200	QCT2201
CTFP R/L 5050 T22	CT220301	BE03000	GS08000	SS40	GS08001	QCT2200	QCT2201

(C) TOP CLAMP TOOLHOLDERS

Medium to Finishing	Finishing to Fine Finishing	Medium
Flat  (11-16-22)	12  (11-16)	13  (11-16-22)









Order Code		Reference	Dimensions (mm)					Insert	Kg	Stock	
R	L		H=h	b	L1	L2	S			R	L
212272800	212272900	CTGP R/L 1010 E11	10	10	70	16	12	TP.. 1103..	0,030		
212273000	212020200	CTGP R/L 1212 F11	12	12	80	18	16	TP.. 1103..	0,070		
212273100	212273200	CTGP R/L 1616 H11	16	16	100	22	20	TP.. 1103..	0,200		
212033100	212033200	CTGP R/L 2020 K11	20	20	125	22	25	TP.. 1103..	0,400		
212033300	212033400	CTGP R/L 2020 K16	20	20	125	28	25	TP.. 1603..	0,400		
212035800	212033500	CTGP R/L 2525 M16	25	25	150	28	32	TP.. 1603..	0,700		
212273300	212273400	CTGP R/L 3225 P16	32	25	170	28	32	TP.. 1603..	1,000		
212273500	212273600	CTGP R/L 3232 P22	32	32	170	34	40	TP.. 2204..	1,250		
212273700	212273800	CTGP R/L 4040 S22	40	40	250	34	50	TP.. 2204..	3,000		
212273900	212274000	CTGP R/L 5050 T22	50	50	300	34	60	TP.. 2204..	5,650		

 Stock Items | Itens de stock



 Available under request | Disponível sob consulta | Disponible bajo consulta

SPARE PARTS | Complementos | Repuestos









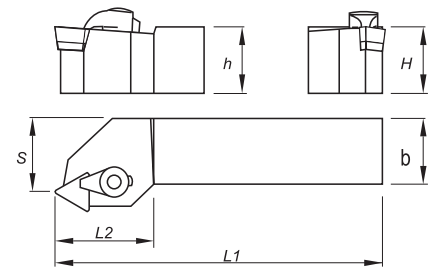
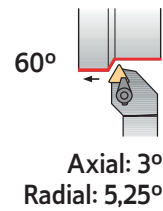







Complementary Accessories - Flat Inserts

Cutter Reference	Shim	Shim Pin	Clamp	Wrench	Clamp	Chip Breaker 1	Chip Breaker 2
							
CTGP R/L 1010 E11	-	-	GS03000	SS15	-	-	-
CTGP R/L 1212 F11	-	-	GS05001	SS25	GS05004	QCT1100	QCT1101
CTGP R/L 1616 H11	-	-	GS05001	SS25	GS05004	QCT1100	QCT1101
CTGP R/L 2020 K11	-	-	GS05001	SS25	GS05004	QCT1100	QCT1101
CTGP R/L 2020 K16	CT160301	BE02100	GS06000	SS30	GS05005	QCT1600	QCT1601
CTGP R/L 2525 M16	CT160301	BE02100	GS06000	SS30	GS05005	QCT1600	QCT1601
CTGP R/L 3225 P16	CT160301	BE02100	GS06000	SS30	GS05005	QCT1600	QCT1601
CTGP R/L 3232 P22	CT220301	BE03000	GS08000	SS40	GS08001	QCT2200	QCT2201
CTGP R/L 4040 S22	CT220301	BE03000	GS08000	SS40	GS08001	QCT2200	QCT2201
CTGP R/L 5050 T22	CT220301	BE03000	GS08000	SS40	GS08001	QCT2200	QCT2201

(C) TOP CLAMP TOOLHOLDERS

Medium to Finishing	Finishing to Fine Finishing	Medium
Flat  (11-16)	12  (09-11-16)	13  (09-11-16)



Order Code		Reference	Dimensions (mm)					Insert	Kg	Stock	
R	L		H=h	b	L1	L2	S			R	L
212249500	212274100	CTTP R/L 0808 D09	8	8	60	16	7	TP.. 0902..	0,020		
212274200	212274300	CTTP R/L 1010 E09	10	10	70	16	9	TP.. 0902..	0,030		
212274400	212274500	CTTP R/L 1010 E11	10	10	70	16	9	TP.. 1103..	0,030		
212274600	212274700	CTTP R/L 1212 F11	12	12	80	18	11	TP.. 1103..	0,070		
212274800	212274900	CTTP R/L 1616 H11	16	16	100	22	13	TP.. 1103..	0,200		
212275000	212275100	CTTP R/L 2020 K11	20	20	125	22	17	TP.. 1103..	0,400		
212275200	212275300	CTTP R/L 2020 K16	20	20	125	28	17	TP.. 1603..	0,400		
212247400	212275400	CTTP R/L 2525 M16	25	25	150	28	22	TP.. 1603..	0,700		

 Stock Items | Itens de stock

 Available under request | Disponível sob consulta | Disponible bajo consulta

SPARE PARTS | Complementos | Repuestos

Complementary Accessories - Flat Inserts

Cutter Reference	Shim	Shim Pin	Clamp	Wrench	Clamp	Chip Breaker 1	Chip Breaker 2
							
CTTP R/L 0808 D09	-	-	GS03000	SS15	-	-	-
CTTP R/L 1010 E09	-	-	GS03000	SS15	-	-	-
CTTP R/L 1010 E11	-	-	GS03000	SS15	GS05004	QCT1100	QCT1101
CTTP R/L 1212 F11	-	-	GS05001	SS25	GS05004	QCT1100	QCT1101
CTTP R/L 1616 H11	-	-	GS05001	SS25	GS05004	QCT1100	QCT1101
CTTP R/L 2020 K11	-	-	GS05001	SS25	GS05004	QCT1100	QCT1101
CTTP R/L 2020 K16	CT160301	BE02100	GS06000	SS30	GS05005	QCT1600	QCT1601
CTTP R/L 2525 M16	CT160301	BE02100	GS06000	SS30	GS05005	QCT1600	QCT1601

(D) DIMPLE LOCK SYSTEM

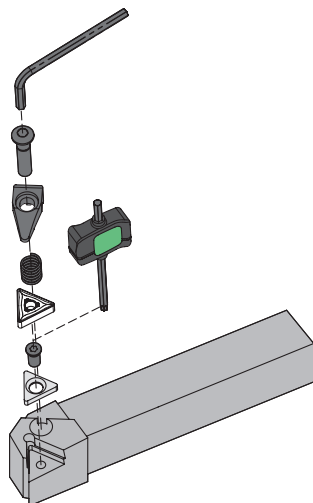

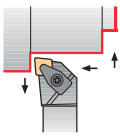
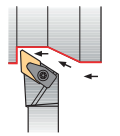
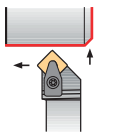
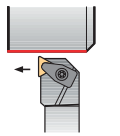
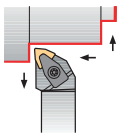
<p>DCLN 95°</p>  <p>PAGE C - 542 CN.. 1204.. CN.. 1906..</p>	<p>DDJN 93°</p>  <p>PAGE C - 543 DN.. 1104.. DN.. 1506..</p>	<p>DSSN 45°</p>  <p>PAGE C - 544 SN.. 1204.. SN.. 1906..</p>	<p>DTGN 90°</p>  <p>PAGE C - 545 TN.. 1604.. TN.. 2204..</p>	<p>DWLN 95°</p>  <p>PAGE C - 546 WN.. 0604.. WN.. 0804..</p>
--	--	--	--	--

(D) DIMPLE LOCK TOOLHOLDERS

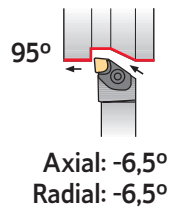

Roughing	Finishing	Medium to Finishing	Medium to Finishing	Medium	Medium	Medium
Flat Flat (12-19)	MF (12)	SF (12)	LC (12)	MS (12)	MR (12-19)	PM (12)
Medium	Medium Wiper	Roughing to Medium	Roughing	Roughing	Heavy to Roughing	Heavy to Roughing
ST (12-19)	MW (12)	SS (12-19)	HR (12-19)	RP (19)	HY (19)	HZ (19)

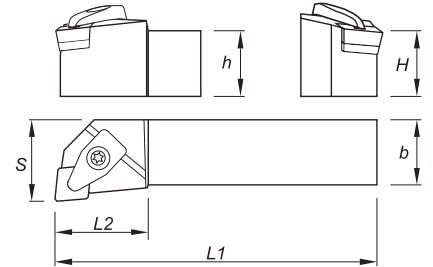

Order Code		Reference	Dimensions (mm)					Insert	Kg	Stock	
R	L		H=h	b	L1	L2	S			R	L
212275500	212275600	DCLN R/L 2020 K12	20	20	125	28	25	CN.. 1204..	0,400		
212219600	212246600	DCLN R/L 2525 M12	25	25	150	28	32	CN.. 1204..	0,750		
212275700	212249200	DCLN R/L 3232 P12	32	32	170	28	40	CN.. 1204..	1,300		
212275800	212275900	DCLN R/L 3232 P19	32	32	170	42	40	CN.. 1906..	1,300		
212276000	212276100	DCLN R/L 4040 S19	40	40	250	45	50	CN.. 1906..	3,050		















Stock Items | Itens de stock

Available under request | Disponível sob consulta | Disponible bajo consulta







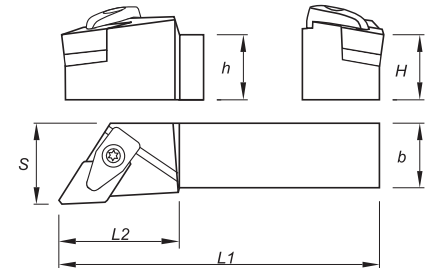
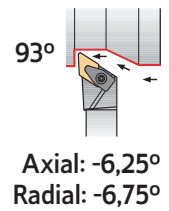

SPARE PARTS | Complementos | Repuestos

Cutter Reference	Shim	Shim Screw	Spring	Clamp	Clamp Screw	Wrench
DCLN R/L 2020 K12	CC120600	T06010000	M09513	GA07002	D0602900	SS40
DCLN R/L 2525 M12	CC120600	T06010000	M09513	GA07002	D0602900	SS40
DCLN R/L 3232 P12	CC120600	T06010000	M09513	GA07002	D0602900	SS40
DCLN R/L 3232 P19	CC190502	T06015000	M09513	GA07003	D0602900	SS40
DCLN R/L 4040 S19	CC190502	T06015000	M09513	GA07003	D0602900	SS40

(D) DIMPLE LOCK TOOLHOLDERS

Roughing	Finishing	Medium to Finishing	Medium to Finishing	Medium	Medium	Medium	Medium
Flat	MF	SF	LC	MS	MR	PM	ST
 (11-15)	 (11-15)	 (11-15)	 (15)	 (15)	 (11-15)	 (15)	 (11-15)
Medium Wiper	Roughing to Medium	Roughing	Roughing	Roughing to Medium	Medium to Finishing	Medium to Finishing	
MW	SS	HR	RP	O1	O2	O3	
 (15)	 (11-15)	 (15)	 (15)	 (15)	 (15)	 (15)	









Order Code		Reference	Dimensions (mm)					Insert	Kg	Stock	
R	L		H=h	b	L1	L2	S			R	L
212422900	212423000	DDJN R/L 2020 K11	20	20	125	34	25,0	DN.. 1104..	0,400		
212065900	212276200	DDJN R/L 2020 K15	20	20	125	34	25	DN.. 1506..	0,400		
212219300	212168000	DDJN R/L 2525 M15	25	25	150	34	32	DN.. 1506..	0,750		
212276300	212249400	DDJN R/L 3232 P15	32	32	170	34	40	DN.. 1506..	1,300		











 Stock Items | Itens de stock

 Available under request | Disponível sob consulta | Disponible bajo consulta









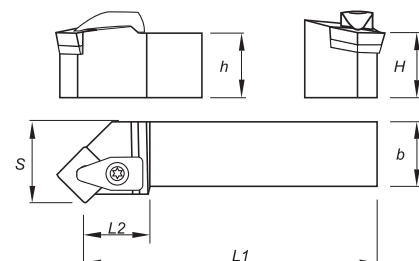
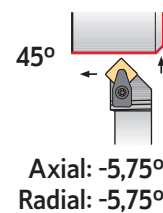

SPARE PARTS | Complementos | Repuestos

Cutter Reference	Shim	Shim Screw	Spring	Clamp	Clamp Screw	Wrench
						
DDJN R/L 2020 K11	CD110302	T05008000	M06511	GA05001	D0500801	SS40
DDJN R/L 2020 K15	CD150501	T06010000	M09513	GA07002	D0602900	SS40
DDJN R/L 2525 M15	CD150501	T06010000	M09513	GA07002	D0602900	SS40
DDJN R/L 3232 P15	CD150501	T06010000	M09513	GA07002	D0602900	SS40

(D) DIMPLE LOCK TOOLHOLDERS







Roughing	Finishing	Medium	Medium	Medium	Medium
Flat  (12-19)	MF  (12)	SF  (12)	MR  (12-19)	PM  (12)	ST  (12-19)
Roughing to Medium	Roughing	Roughing	Heavy to Roughing	Heavy to Roughing	
SS  (12-19)	HR  (12-19)	RP  (19)	HY  (19)	HZ  (19)	













Order Code		Reference	Dimensions (mm)					Insert	Kg	Stock	
R	L		H=h	b	L1	L2	S			R	L
212066000	212276400	DSSN R/L 2020 K12	20	20	125	28	25	SN.. 1204..	0,400		
212245800	212276500	DSSN R/L 2525 M12	25	25	150	28	32	SN.. 1204..	0,750		
212276600	212276700	DSSN R/L 3225 P12	32	25	170	28	32	SN.. 1204..	1,050		
212276800	212276900	DSSN R/L 3232 P19	32	32	170	42	40	SN.. 1906..	1,300		
212277000	212277100	DSSN R/L 4040 S19	40	40	250	45	50	SN.. 1906..	3,050		

 Stock Items | Itens de stock  Available under request | Disponível sob consulta | Disponible bajo consulta  Stock available until sold out | Stock disponível até acabar o stock | Stock disponible hasta acabar el stock







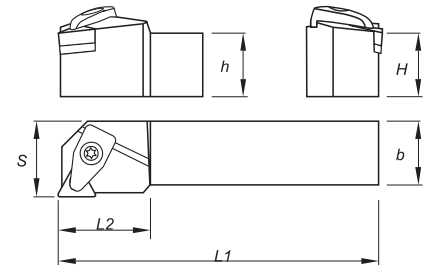
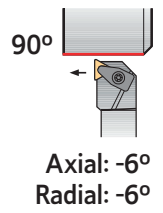

SPARE PARTS || Complementos | Repuestos

Cutter Reference	Shim	Shim Screw	Spring	Clamp	Clamp Screw	Wrench
DSSN R/L 2020 K12						
DSSN R/L 2525 M12	CS120600	T06010000	M09513	GA07002	D0602900	SS40
DSSN R/L 3225 P12	CS120600	T06010000	M09513	GA07002	D0602900	SS40
DSSN R/L 3232 P19	CS190501	T06015000	M09513	GA07003	D0602900	SS40
DSSN R/L 4040 S19	CS190400	P0801411	M09513	GA07001	D0702800	SS40

(D) DIMPLE LOCK TOOLHOLDERS

Roughing	Finishing	Medium to Finishing	Medium to Finishing	Medium	Medium
Flat	MF	SF	LC	MS	MR
 (16-22)	 (16-22)	 (16-22)	 (16-22)	 (16)	 (16-22)
Medium	Medium	Roughing to Medium	Roughing	Medium to Finishing	
PM	ST	SS	HR	O1	
 (16-22)	 (16-22)	 (16-22)	 (16-22)	 (16)	









Order Code		Reference	Dimensions (mm)					Insert	Kg	Stock	
R	L		H=h	b	L1	L2	S			R	L
212277200	212277300	DTGN R/L 2020 K16	20	20	125	28	25	TN.. 1604..	0,400		
212219500	212277400	DTGN R/L 2525 M16	25	25	150	28	32	TN.. 1604..	0,750		
212277500	212277600	DTGN R/L 2525 M22	25	25	150	34	32	TN.. 2204..	0,750		
212277700	212277800	DTGN R/L 3232 P22	32	32	170	34	40	TN.. 2204..	1,300		

 Stock Items | Itens de stock

 Available under request | Disponivel sob consulta | Disponible bajo consulta

SPARE PARTS | Complementos | Repuestos

Cutter Reference	Shim	Shim Screw	Spring	Clamp	Clamp Screw	Wrench
DTGN R/L 2020 K16						
DTGN R/L 2525 M16	CT160600	T05008000	M06511	GA05001	D0500801	SS40
DTGN R/L 2525 M22	CT220600	T06010000	M09513	GA07002	D0602900	SS40
DTGN R/L 3232 P22	CT220600	T06010000	M09513	GA07002	D0602900	SS40

(D) DIMPLE LOCK TOOLHOLDERS

Roughing	Finishing	Medium to Finishing	Medium to Finishing	Medium to Finishing	Medium
Flat (06-08)	MF (06-08)	SF (06-08)	LC (08)	MS (06-08)	PM (06-08)
Medium	Medium	Medium Wiper	Roughing to Medium	Roughing	
MR (06-08)	ST (08)	MW (06-08)	SS (06-08)	HR (08)	

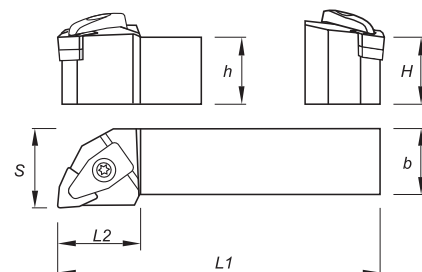
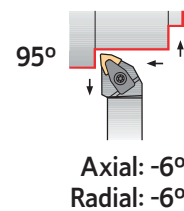

Order Code		Reference	Dimensions (mm)					Insert	Kg	Stock	
R	L		H=h	b	L1	L2	S			R	L
212425100	212425200	DWLN R/L 2020 K06	20	20	125	34	25	WN.. 0604..	0,400		
212425300	212425400	DWLN R/L 2525 M06	25	25	150	34	25	WN.. 0604..	0,400		
212277900	212278000	DWLN R/L 2020 K08	20	20	125	34	25	WN.. 0804..	0,400		
212219400	212246300	DWLN R/L 2525 M08	25	25	150	34	32	WN.. 0804..	0,750		
212278100	212278200	DWLN R/L 3232 P08	32	32	170	34	40	WN.. 0804..	1,300		





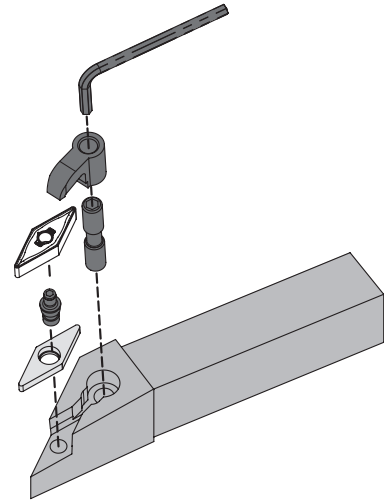
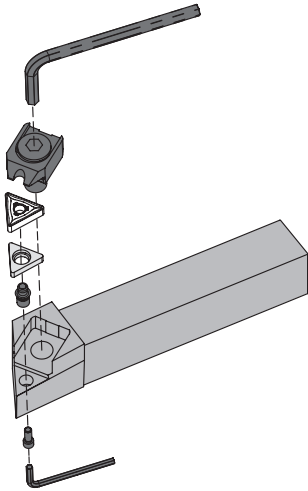









Stock Items | Itens de stock Available under request | Disponível sob consulta | Disponible bajo consulta

Cutter Reference	Shim	Shim Screw	Spring	Clamp	Clamp Screw	Wrench
DWLN R/L 2020 K06	CW060302	T05008000	M06511	GA05001	D0500801	SS40
DWLN R/L 2525 M06	CW060302	T05008000	M06511	GA05001	D0500801	SS40
DWLN R/L 2020 K08	CW080500	T06010000	M09513	GA07002	D0602900	SS40
DWLN R/L 2525 M08	CW080500	T06010000	M09513	GA07002	D0602900	SS40
DWLN R/L 3232 P08	CW080500	T06010000	M09513	GA07002	D0602900	SS40









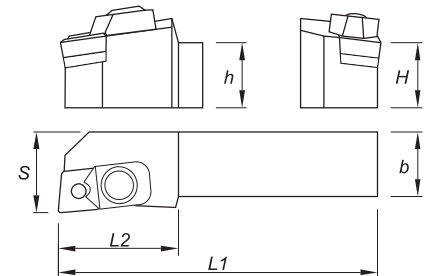
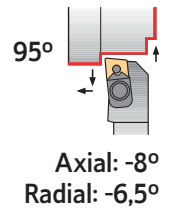





MCLN 95° PAGE C - 548 CN.. 1204.. CN.. 1906..	MCLN-K 95° PAGE C - 549 CN.. 1204.. CN.. 1906..	MDJN-K 93° PAGE C - 550 DN.. 1506..	MSSN-K 45° PAGE C - 551 SN.. 1204..	MSSN 45° PAGE C - 552 SN.. 1204.. SN.. 1906..	MTEN 60° PAGE C - 553 TN.. 1604.. TN.. 2204..
MTJN 93° PAGE C - 554 TN.. 1604.. TN.. 2204..	MTJN-K 93° PAGE C - 555 TN.. 1604.. TN.. 2204..	MTNN 63° PAGE C - 556 TN.. 1604.. TN.. 2204..	MVJN-K 93° PAGE C - 557 VN.. 1604..	MVQN-K 117°30' PAGE C - 558 VN.. 1604..	MVVN-K 72°30' PAGE C - 559 VN.. 1604..
MWLN 95° PAGE C - 560 WN.. 0604.. WN.. 0804..	MWLN-K 95° PAGE C - 561 WN.. 0804..				

(M) WEDGE CLAMP SYSTEM

Roughing	Finishing	Medium to Finishing	Medium to Finishing	Medium	Medium	Medium
Flat  (12-19)	MF  (12)	SF  (12)	LC  (12)	MS  (12)	MR  (12-19)	PM  (12)
Medium	Medium Wiper	Roughing to Medium	Roughing	Roughing	Heavy to Roughing	Heavy to Roughing
ST  (12-19)	MW  (12)	SS  (12-19)	HR  (12-19)	RP  (19)	HY  (19)	HZ  (19)







Order Code		Reference	Dimensions (mm)					Insert	Kg	Stock	
R	L		H=h	b	L1	L2	S			R	L
212245900	212278300	MCLN R/L 2020 K12	20	20	125	34	25	CN.. 1204..	0,450		
212246000	212010500	MCLN R/L 2525 M12	25	25	150	34	32	CN.. 1204..	0,800		
212278400	212278500	MCLN R/L 3225 P12	32	25	170	34	32	CN.. 1204..	1,200		
212278600	212278700	MCLN R/L 2525 M19	25	25	150	42	32	CN.. 1906..	0,800		
212278800	212278900	MCLN R/L 3225 P19	32	25	170	42	32	CN.. 1906..	1,200		
212279000	212279100	MCLN R/L 4040 S19	40	40	250	42	50	CN.. 1906..	3,100		















 Stock Items | Itens de stock

 Available under request | Disponível sob consulta | Disponible bajo consulta









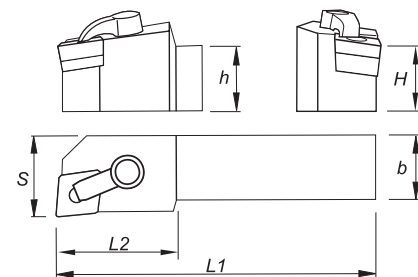
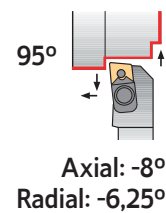

SPARE PARTS | Complementos | Repuestos

Cutter Reference	Shim 	Lock Pin 	lock Pin Screw 	Wedge Clamp 	Wrench 
MCLN R/L 2020 K12	CC120500	BC06000	D0400900	GW08002	SS50
MCLN R/L 2525 M12	CC120500	BC06000	D0400900	GW08002	SS50
MCLN R/L 3225 P12	CC120500	BC06000	D0400900	GW08002	SS50
MCLN R/L 2525 M19	CC190500	BC08000	D0602200	GW08003	SS50
MCLN R/L 3225 P19	CC190500	BC08000	D0602200	GW08003	SS50
MCLN R/L 4040 S19	CC190500	BC08000	D0602200	GW08003	SS50

(M-K) DOUBLE LOCK SYSTEM

Roughing	Finishing	Medium to Finishing	Medium to Finishing	Medium	Medium	Medium
Flat  (12-19)	MF  (12)	SF  (12)	LC  (12)	MS  (12)	MR  (12-19)	PM  (12)
Medium	Medium Wiper	Roughing to Medium	Roughing	Roughing	Heavy to Roughing	Heavy to Roughing
ST  (12-19)	MW  (12)	SS  (12-19)	HR  (12-19)	RP  (19)	HY  (19)	HZ  (19)

































Order Code		Reference	Dimensions (mm)					Insert	Kg	Stock	
R	L		H=h	b	L1	L2	S			R	L
212286200	212286300	MCLN R/L 2020 K12-K	20	20	125	28	25	CN.. 1204..	0,450		
212286400	212286500	MCLN R/L 2525 M12-K	25	25	150	28	32	CN.. 1204..	0,800		
212286600	212286700	MCLN R/L 3225 P12-K	32	25	170	28	32	CN.. 1204..	1,200		
212286800	212286900	MCLN R/L 2525 M19-K	25	25	150	42	32	CN.. 1906..	0,800		
212287000	212287100	MCLN R/L 3232 P19-K	32	32	170	42	40	CN.. 1906..	1,400		

 Stock Items | Itens de stock

 Available under request | Disponível sob consulta | Disponible bajo consulta

SPARE PARTS | Complementos | Repuestos

Cutter Reference	Shim	Lock Pin	Lock Pin Wrench	Clamp	Differential Screw	Clamp Wrench
MCLN R/L 2020 K12-K	 CC120500	 BS1-400	 SS25	 GA06000	 F0602900	 SS30
MCLN R/L 2525 M12-K	 CC120500	 BS1-400	 SS25	 GA06000	 F0602900	 SS30
MCLN R/L 3225 P12-K	 CC120500	 BS1-400	 SS25	 GA06000	 F0602900	 SS30
MCLN R/L 2525 M19-K	 CC190502	 BS3-800	 SS40	 GA06003	 F0802900	 SS40
MCLN R/L 3232 P19-K	 CC190502	 BS3-800	 SS40	 GA06003	 F0802900	 SS40



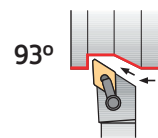

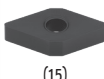
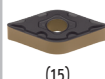
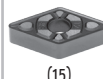
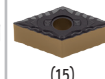
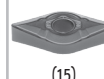
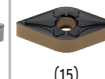
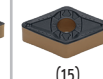
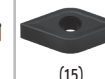
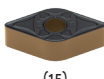
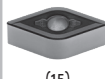
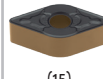
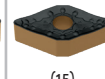
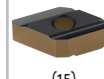
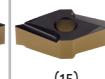
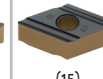

(M-K) DOUBLE LOCK SYSTEM

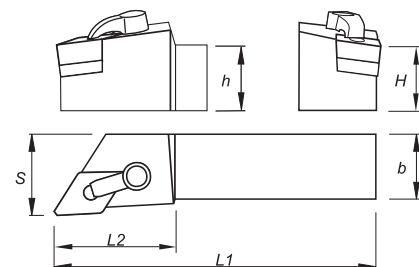

Axial: -6°
Radial: -7°

Roughing	Finishing	Medium to Finishing	Medium to Finishing	Medium	Medium	Medium	Medium
Flat	MF	SF	LC	MS	MR	PM	ST
 (15)	 (15)	 (15)	 (15)	 (15)	 (15)	 (15)	 (15)
Medium Wiper	Roughing to Medium	Roughing	Roughing	Roughing to Medium	Medium to Finishing	Medium to Finishing	
MW	SS	HR	RP	O1	O2	O3	
 (15)	 (15)	 (15)	 (15)	 (15)	 (15)	 (15)	









Order Code		Reference	Dimensions (mm)					Insert	Kg	Stock	
R	L		H=h	b	L1	L2	S			R	L
212287200	212287300	MDJN R/L 2020 K15-K	20	20	125	34	25	DN.. 1506..	0,450		
212287400	212287500	MDJN R/L 2525 M15-K	25	25	150	34	32	DN.. 1506..	0,800		
212287600	212287700	MDJN R/L 3225 P15-K	32	25	170	34	32	DN.. 1506..	1,200		









 Stock Items | Itens de stock

 Available under request | Disponível sob consulta | Disponible bajo consulta





SPARE PARTS | Complementos | Repuestos

Cutter Reference	Shim	Lock Pin	Lock Pin Wrench	Clamp	Differential Screw	Clamp Wrench
						
MDJN R/L 2020 K15-K	CD150501	BS1-401	SS25	GA06001	F0602900	SS30
MDJN R/L 2525 M15-K	CD150501	BS1-401	SS25	GA06001	F0602900	SS30
MDJN R/L 3225 P15-K	CD150501	BS1-401	SS25	GA06001	F0602900	SS30

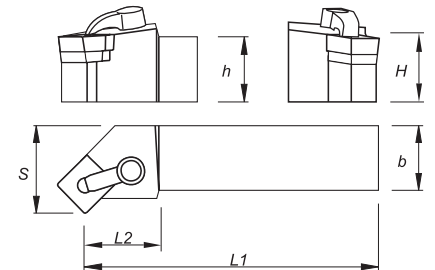
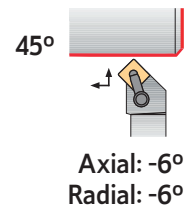
(M-K) DOUBLE LOCK SYSTEM

Roughing	Finishing	Medium to finishing	Medium
Flat  (12)	MF  (12)	SF  (12)	MR  (12)
Medium	Medium	Roughing to Medium	Roughing
PM  (12)	ST  (12)	SS  (12)	HR  (12)









Order Code		Reference	Dimensions (mm)					Insert	Kg	Stock	
R	L		H=h	b	L1	L2	S			R	L
212287800	212287900	MSSN R/L 2020 K12-K	20	20	125	28	27	SN.. 1204..	0,450		
212288000	212288100	MSSN R/L 2525 M12-K	25	25	150	28	32	SN.. 1204..	0,800		

 Stock Items | Itens de stock

 Available under request | Disponível sob consulta | Disponible bajo consulta

SPARE PARTS | Complementos | Repuestos

Cutter Reference	Shim 	Lock Pin 	Lock Pin Wrench 	Clamp 	Differential Screw 	Clamp Wrench 
MSSN R/L 2020 K12-K	CS120500	BS1-400	SS25	GA06000	F0602900	SS30
MSSN R/L 2525 M12-K	CS120500	BS1-400	SS25	GA06000	F0602900	SS30

(M) WEDGE CLAMP SYSTEM

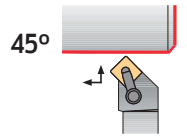

Axial: -6°
Radial: -6°

Roughing	Finishing	Medium	Medium	Medium	Medium
Flat (12-19)	MF (12)	SF (12)	MR (12-19)	PM (12)	ST (12-19)
Roughing to Medium	Roughing	Roughing	Heavy to Roughing	Heavy to Roughing	
SS (12-19)	HR (12-19)	RP (19)	HY (19)	HZ (19)	

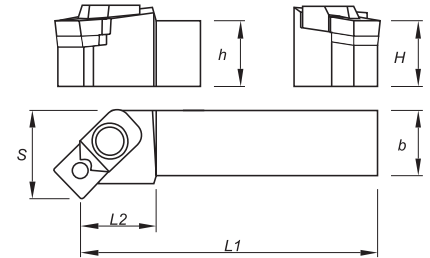

Order Code		Reference	Dimensions (mm)					Insert	Kg	Stock	
R	L		H=h	b	L1	L2	S			R	L
212279200	212279300	MSSN R/L 2020 K12	20	20	125	34	27	SN.. 1204..	0,450		
212279400	212279500	MSSN R/L 2525 M12	25	25	150	34	32	SN.. 1204..	0,800		
212279600	212279700	MSSN R/L 3225 P12	32	25	170	34	32	SN.. 1204..	1,200		
212279800	212279900	MSSN R/L 2525 M19	25	25	150	42	32	SN.. 1906..	0,800		
212280000	212280100	MSSN R/L 3225 P19	32	25	170	42	32	SN.. 1906..	1,200		
212280200	212280300	MSSN R/L 3232 P19	32	32	170	42	40	SN.. 1906..	1,400		
212280400	212280500	MSSN R/L 4040 S19	40	40	250	42	50	SN.. 1906..	3,100		











Stock Items | Itens de stock

Available under request | Disponível sob consulta | Disponible bajo consulta









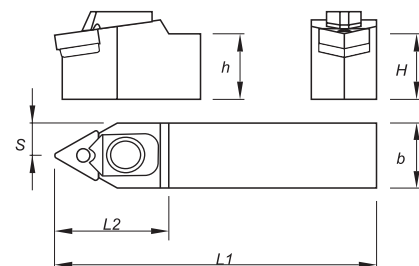
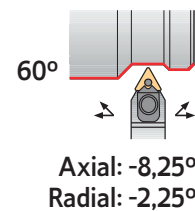















SPARE PARTS || Complementos | Repuestos

Cutter Reference	Shim 	Lock Pin 	Lock Pin Screw 	Wedge Clamp 	Wrench
MSSN R/L 2020 K12	CS120400	BC06000	D0400900	GW08001	SS50
MSSN R/L 2525 M12	CS120400	BC06000	D0400900	GW08001	SS50
MSSN R/L 3225 P12	CS120400	BC06000	D0400900	GW08001	SS50
MSSN R/L 2525 M19	CS190400	BC08000	D0601400	GW08003	SS50
MSSN R/L 3225 P19	CS190400	BC08000	D0601400	GW08003	SS50
MSSN R/L 3232 P19	CS190400	BC08000	D0601400	GW08003	SS50
MSSN R/L 4040 S19	CS190400	BC08000	D0601400	GW08003	SS50

(M) WEDGE CLAMP SYSTEM

Roughing	Finishing	Medium to Finishing	Medium to Finishing	Medium	Medium
Flat	MF	SF	LC	MS	MR
 (16-22)	 (16-22)	 (16-22)	 (16-22)	 (16)	 (16-22)
Medium	Medium	Roughing to Medium	Roughing	Medium to Finishing	
PM	ST	SS	HR	O1	
 (16-22)	 (16-22)	 (16-22)	 (16-22)	 (16)	







Order Code		Reference	Dimensions (mm)					Insert	Kg	Stock	
R	L		H=h	b	L1	L2	S			R	L
212280600	212280700	MTEN R/L 2020 K16	20	20	125	34	10,5	TN.. 1604..	0,450		
212054800	212280900	MTEN R/L 2525 M16	25	25	150	34	13,0	TN.. 1604..	0,800		
212281000	212281100	MTEN R/L 3225 P16	32	25	170	34	13,0	TN.. 1604..	1,200		
212168800	212281300	MTEN R/L 2525 M22	25	25	150	42	13,0	TN.. 2204..	0,800		
212281500	212281600	MTEN R/L 3225 P22	32	25	170	42	13,0	TN.. 2204..	1,200		
212281800	212281900	MTEN R/L 3232 P22	32	32	170	42	16,5	TN.. 2204..	1,400		
212282100	212282200	MTEN R/L 4025 R22	40	25	200	42	13,0	TN.. 2204..	1,500		
212282400	212282500	MTEN R/L 5032 S22	50	32	250	45	16,5	TN.. 2204..	2,950		
212280800		MTEN N 2020 K16	20	20	125	34	10,5	TN.. 1604..	0,450		
212169700		MTEN N 2525 M16	25	25	150	34	13,0	TN.. 1604..	0,800		
212281200		MTEN N 3225 P16	32	25	170	34	13,0	TN.. 1604..	1,200		
212281400		MTEN N 2525 M22	25	25	150	42	13,0	TN.. 2204..	0,800		
212281700		MTEN N 3225 P22	32	25	170	42	13,0	TN.. 2204..	1,200		
212282000		MTEN N 3232 P22	32	32	170	42	16,5	TN.. 2204..	1,400		
212282300		MTEN N 4025 R22	40	25	200	42	13,0	TN.. 2204..	1,500		
212282600		MTEN N 5032 S22	50	32	250	45	16,5	TN.. 2204..	2,950		

 Stock Items | Itens de stock

 Available under request | Disponível sob consulta | Disponible bajo consulta









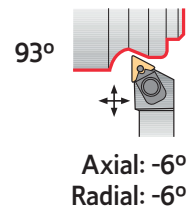



SPARE PARTS || Complementos | Repuestos

Cutter Reference	Shim	Lock Pin	Lock Pin Screw	Wedge Clamp	Wrench
					
MTEN R/L/N 2020 K16	CT160302	BC04500	D0300700	GW08001	SS50
MTEN R/L/N 2525 M16	CT160302	BC04500	D0300700	GW08001	SS50
MTEN R/L/N 3225 P16	CT160302	BC04500	D0300700	GW08001	SS50
MTEN R/L/N 2525 M22	CT220500	BC06000	D0400900	GW08003	SS50
MTEN R/L/N 3225 P22	CT220500	BC06000	D0400900	GW08003	SS50
MTEN R/L/N 3232 P22	CT220500	BC06000	D0400900	GW08003	SS50
MTEN R/L/N 4025 R22	CT220500	BC06000	D0400900	GW08003	SS50
MTEN R/L/N 5032 S22	CT220500	BC06000	D0400900	GW08003	SS50









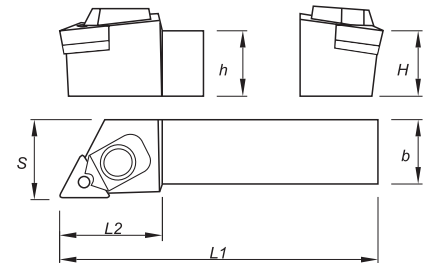







C
TURNING
Insert selection
Overview
Negative inserts
Positive inserts
PCBN & PCD inserts
Heavy turning
External Toolholders
Internal Toolholders
Automatic Lathes
Spare Parts
Technical Data

(M) WEDGE CLAMP SYSTEM



Roughing	Finishing	Medium to Finishing	Medium to Finishing	Medium	Medium
Flat	MF	SF	LC	MS	MR
 (16-22)	 (16-22)	 (16-22)	 (16-22)	 (16)	 (16-22)
Medium	Medium	Medium	Roughing to Medium	Roughing	Medium to Finishing
PM	ST	MW	SS	HR	O1
 (16-22)	 (16-22)	 (16-22)	 (16-22)	 (16-22)	 (16)







Order Code		Reference	Dimensions (mm)					Insert	Kg	Stock	
R	L		H=h	b	L1	L2	S			R	L
212054100	212282700	MTJN R/L 2020 K16	20	20	125	34	25	TN.. 1604..	0,450		
212026100	212047700	MTJN R/L 2525 M16	25	25	150	34	32	TN.. 1604..	0,800		
212010600	212282800	MTJN R/L 3225 P16	32	25	170	34	32	TN.. 1604..	1,200		
212282900	212283000	MTJN R/L 2525 M22	25	25	150	42	32	TN.. 2204..	0,800		
212283100	212283200	MTJN R/L 3225 P22	32	25	170	42	32	TN.. 2204..	1,200		
212283300	212283400	MTJN R/L 3232 P22	32	32	170	42	40	TN.. 2204..	1,400		
212283500	212283600	MTJN R/L 4025 R22	40	25	200	42	32	TN.. 2204..	1,500		
212010700	212283700	MTJN R/L 5032 S22	50	32	250	45	40	TN.. 2204..	2,950		













 Stock Items | Itens de stock

 Available under request | Disponível sob consulta | Disponible bajo consulta









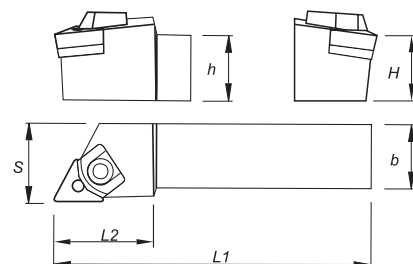
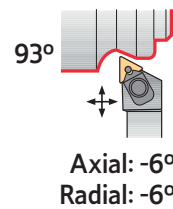





SPARE PARTS | Complementos | Repuestos

Cutter Reference	Shim	Lock Pin	Lock Pin Screw	Wedge Clamp	Wrench
MTJN R/L 2020 K16	 CT160302	 BC04500	 D0300700	 GW08001	 SS50
MTJN R/L 2525 M16	CT160302	BC04500	D0300700	GW08001	SS50
MTJN R/L 3225 P16	CT160302	BC04500	D0300700	GW08001	SS50
MTJN R/L 2525 M22	CT220500	BC06000	D0400900	GW08003	SS50
MTJN R/L 3225 P22	CT220500	BC06000	D0400900	GW08003	SS50
MTJN R/L 3232 P22	CT220500	BC06000	D0400900	GW08003	SS50
MTJN R/L 4025 R22	CT220500	BC06000	D0400900	GW08003	SS50
MTJN R/L 5032 S22	CT220500	BC06000	D0400900	GW08003	SS50

(M-K) DOUBLE LOCK SYSTEM

Roughing	Finishing	Medium to Finishing	Medium to Finishing	Medium	Medium
Flat	MF	SF	LC	MS	MR
 (16-22)	 (16-22)	 (16-22)	 (16-22)	 (16)	 (16-22)
Medium	Medium	Medium	Roughing to Medium	Roughing	Medium to Finishing
PM	ST	MW	SS	HR	O1
 (16-22)	 (16-22)	 (16-22)	 (16-22)	 (16-22)	 (16)





































Order Code		Reference	Dimensions (mm)					Insert	Kg	Stock	
R	L		H=h	b	L1	L2	S			R	L
212289300	212289400	MTJN R/L 2020 K16-K	20	20	125	22	25	TN.. 1604..	0,450		
212228600	212289500	MTJN R/L 2525 M16-K	25	25	150	22	32	TN.. 1604..	0,800		
212169600	212289600	MTJN R/L 2525 M22-K	25	25	150	28	32	TN.. 2204..	0,800		
212289700	212289800	MTJN R/L 3225 P22-K	32	25	170	28	32	TN.. 2204..	1,200		
212289900	212290000	MTJN R/L 3232 P22-K	32	32	170	28	40	TN.. 2204..	1,400		
212290100	212290200	MTJN R/L 4025 R22-K	40	25	200	34	32	TN.. 2204..	1,500		
212290300	212290400	MTJN R/L 5032 S22-K	50	32	250	34	40	TN.. 2204..	2,950		

 Stock Items | Itens de stock









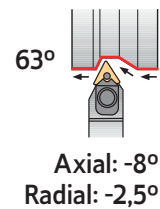

 Available under request | Disponível sob consulta | Disponible bajo consulta

SPARE PARTS || Complementos | Repuestos









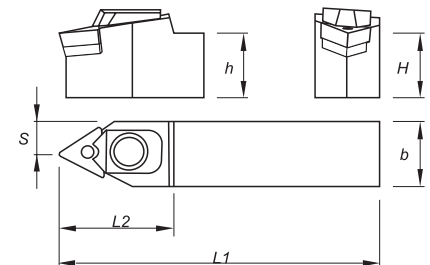







Cutter Reference	Shim	Lock Pin	Lock Pin Screw	Wedge Clamp	Wrench
MTJN R/L 2020 K16-K	 CT160302	 BC04500	 D0300700	 GW05001	 SS25
MTJN R/L 2525 M16-K	 CT160302	 BC04500	 D0300700	 GW05001	 SS25
MTJN R/L 2525 M22-K	 CT220500	 BC06000	 D0400900	 GW06001	 SS30
MTJN R/L 3225 P22-K	 CT220500	 BC06000	 D0400900	 GW06001	 SS30
MTJN R/L 3232 P22-K	 CT220500	 BC06000	 D0400900	 GW06001	 SS30
MTJN R/L 4025 R22-K	 CT220500	 BC06000	 D0400900	 GW06001	 SS30
MTJN R/L 5032 S22-K	 CT220500	 BC06000	 D0400900	 GW06001	 SS30

(M) WEDGE CLAMP SYSTEM



Roughing	Finishing	Medium to Finishing	Medium to Finishing	Medium	Medium
Flat	MF	SF	LC	MS	MR
 (16-22)	 (16-22)	 (16-22)	 (16-22)	 (16)	 (16-22)
Medium	Medium	Roughing to Medium	Roughing	Medium to Finishing	
PM	ST	SS	HR	O1	
 (16-22)	 (16-22)	 (16-22)	 (16-22)	 (16)	







Order Code		Reference	Dimensions (mm)					Insert	Kg	Stock	
R	L		H=h	b	L1	L2	S			R	L
212283800	212283900	MTNN R/L 2020 K16	20	20	125	34	10,0	TN.. 1604..	0,450		
212284000	212043900	MTNN R/L 2525 M16	25	25	150	34	12,5	TN.. 1604..	0,800		
212284100	212284200	MTNN R/L 3225 P16	32	25	170	34	12,5	TN.. 1604..	1,200		
212284300	212284400	MTNN R/L 2525 M22	25	25	150	42	12,5	TN.. 2204..	0,800		
212284500	212284600	MTNN R/L 3225 P22	32	25	170	42	12,5	TN.. 2204..	1,200		
212284700	212284800	MTNN R/L 3232 P22	32	32	170	42	16,0	TN.. 2204..	1,400		
212284900	212285000	MTNN R/L 4025 R22	40	25	200	42	12,5	TN.. 2204..	1,500		
212285100	212285200	MTNN R/L 5032 S22	50	32	250	45	16,0	TN.. 2204..	2,950		







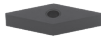
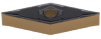

 Stock items | Itens de stock

 Available under request | Disponível sob consulta | Disponible bajo consulta



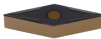

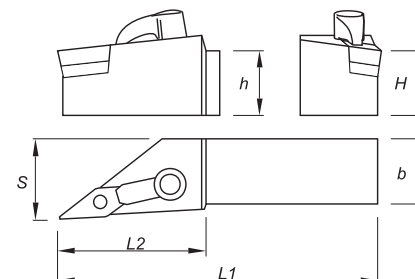
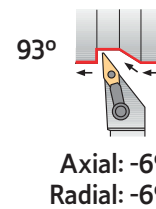

SPARE PARTS | Complementos | Repuestos

Cutter Reference	Shim	Lock Pin	Lock Pin Screw	Wedge Clamp	Wrench
MTNN R/L 2020 K16					
MTNN R/L 2525 M16	CT160302	BC04500	D0300700	GW08001	SS50
MTNN R/L 3225 P16	CT160302	BC04500	D0300700	GW08001	SS50
MTNN R/L 2525 M22	CT220500	BC06000	D0400900	GW08003	SS50
MTNN R/L 3225 P22	CT220500	BC06000	D0400900	GW08003	SS50
MTNN R/L 3232 P22	CT220500	BC06000	D0400900	GW08003	SS50
MTNN R/L 4025 R22	CT220500	BC06000	D0400900	GW08003	SS50
MTNN R/L 5032 S22	CT220500	BC06000	D0400900	GW08003	SS50

(M-K) DOUBLE LOCK SYSTEM

Roughing	Medium to Finishing	Medium to Finishing	Medium to Finishing	Medium to Finishing
Flat	MF	SF	LC	MS
 (16)	 (16)	 (16)	 (16)	 (16)
Medium	Medium	Medium	Roughing to Medium	
MR	PM	ST	SS	
 (16)	 (16)	 (16)	 (16)	





















Order Code		Reference	Dimensions (mm)					Insert	Kg	Stock	
R	L		H=h	b	L1	L2	S			R	L
212050100	212057700	MVJN R/L 2020 K16-K	20	20	125	43	25	VN.. 1604..	0,450		
212246100	212288200	MVJN R/L 2525 M16-K	25	25	150	43	32	VN.. 1604..	0,800		
212288300	212288400	MVJN R/L 3225 P16-K	32	25	170	43	32	VN.. 1604..	1,200		

 Stock Items | Itens de stock

 Available under request | Disponível sob consulta | Disponible bajo consulta







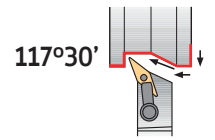

SPARE PARTS || Complementos | Repuestos

Cutter Reference	Shim	Lock Pin	Lock Pin Wrench	Clamp	Differential Screw	Clamp Wrench
MVJN R/L 2020 K16-K	 CV160301	 BS05000	 SS20	 GA06002	 F0602900	 SS30
MVJN R/L 2525 M16-K	 CV160301	 BS05000	 SS20	 GA06002	 F0602900	 SS30
MVJN R/L 3225 P16-K	 CV160301	 BS05000	 SS20	 GA06002	 F0602900	 SS30







(M-K) DOUBLE LOCK SYSTEM

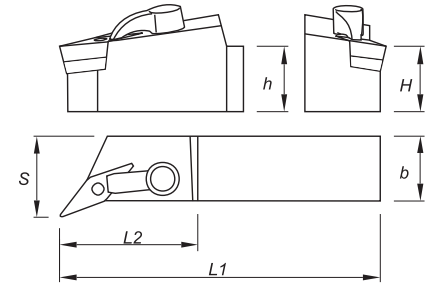

Axial: -8°
Radial: -10°

Roughing	Medium to Finishing	Medium to Finishing	Medium to Finishing	Medium to Finishing
Flat	MF	SF	LC	MS
 (16)	 (16)	 (16)	 (16)	 (16)
Medium	Medium	Medium	Roughing to Medium	
MR	PM	ST	SS	
 (16)	 (16)	 (16)	 (16)	

















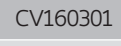



Order Code		Reference	Dimensions (mm)					Insert	Kg	Stock	
R	L		H=h	b	L1	L2	S			R	L
212288500	212288600	MVQN R/L 2020 K16-K	20	20	125	43	25	VN.. 1604..	0,450		
212288700	212288800	MVQN R/L 2525 M16-K	25	25	150	43	32	VN.. 1604..	0,800		
212288900	212289000	MVQN R/L 3225 P16-K	32	25	170	43	32	VN.. 1604..	1,200		

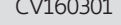





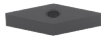
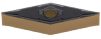

 Stock Items | Itens de stock

 Available under request | Disponível sob consulta | Disponible bajo consulta



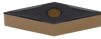

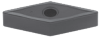
SPARE PARTS || Complementos | Repuestos

Cutter Reference	Shim	Lock Pin	Lock Pin Wrench	Clamp	Differential Screw	Clamp Wrench
MVQN R/L 2020 K16-K	 CV160301	 BS05000	 SS20	 GA06002	 F0602900	 SS30
MVQN R/L 2525 M16-K	 CV160301	 BS05000	 SS20	 GA06002	 F0602900	 SS30
MVQN R/L 3225 P16-K	 CV160301	 BS05000	 SS20	 GA06002	 F0602900	 SS30

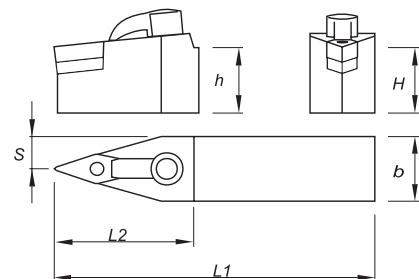
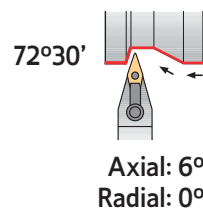
(M-K) DOUBLE LOCK SYSTEM

Roughing	Medium to Finishing	Medium to Finishing	Medium to Finishing	Medium to Finishing
Flat	MF	SF	LC	MS
 (16)	 (16)	 (16)	 (16)	 (16)
Medium	Medium	Medium	Roughing to Medium	
MR	PM	ST	SS	
 (16)	 (16)	 (16)	 (16)	















Order Code	Reference	Dimensions (mm)					Insert	Kg	Stock	
		H=h	b	L1	L2	S			R	L
212289100	MVVN N 2020 K16-K	20	20	125	43	10,0	VN..1604..	0,450		
212289200	MVVN N 2525 M16-K	25	25	150	43	12,5	VN..1604..	0,800		







 Stock Items | Itens de stock

 Available under request | Disponível sob consulta | Disponible bajo consulta









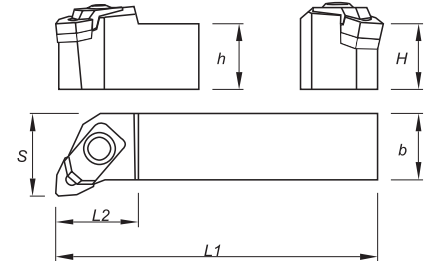
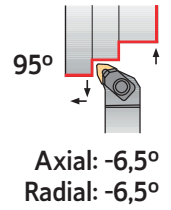





SPARE PARTS || Complementos | Repuestos

Cutter Reference	Shim	Lock Pin	Lock Pin Wrench	Clamp	Differential Screw	Clamp Wrench
MVVN N 2020 K16-K	 CV160301	 BS05000	 SS20	 GA06002	 F0602900	 SS30
MVVN N 2525 M16-K	 CV160301	 BS05000	 SS20	 GA06002	 F0602900	 SS30

(M) WEDGE CLAMP SYSTEM

Roughing	Finishing	Medium to Finishing	Medium to Finishing	Medium	Medium
Flat  (08)	MF  (06-08)	SF  (06-08)	LC  (08)	MS  (06-08)	PM  (06-08)
Medium	Medium	Medium Wiper	Roughing to Medium	Roughing	
MR  (06-08)	ST  (08)	MW  (06-08)	SS  (06-08)	HR  (08)	







Order Code		Reference	Dimensions (mm)					Insert	Kg	Stock	
R	L		H=h	b	L1	L2	S			R	L
212285300	212285400	MWLN R/L 1616 H06	16	16	100	15	20	WN.. 0604..	0,200		
212048200	212285500	MWLN R/L 2020 K06	20	20	125	25	25	WN.. 0604..	0,450		
212285600	212285700	MWLN R/L 2525 M06	25	25	150	25	32	WN.. 0604..	0,800		
212246200	212285800	MWLN R/L 2020 K08	20	20	125	34	25	WN.. 0804..	0,450		
212054000	212042400	MWLN R/L 2525 M08	25	25	150	34	32	WN.. 0804..	0,800		
212285900	212286000	MWLN R/L 3225 P08	32	25	170	34	32	WN.. 0804..	1,200		
212010800	212286100	MWLN R/L 3232 P08	32	32	170	34	40	WN.. 0804..	1,400		











 Stock Items | Itens de stock

 Available under request | Disponível sob consulta | Disponible bajo consulta





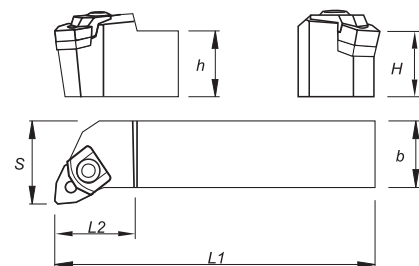
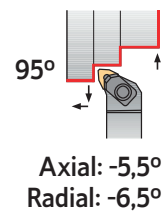

SPARE PARTS | Complementos | Repuestos

Cutter Reference	Shim 	Lock Pin 	Lock Pin Screw 	Wedge Clamp 	Wrench 
MWLN R/L 1616 H06	CW060300	BC04501	D0300700	GW05000	SS25
MWLN R/L 2020 K06	CW060300	BC04500	D0300700	GW05000	SS25
MWLN R/L 2525 M06	CW060300	BC04500	D0300700	GW05000	SS25
MWLN R/L 2020 K08	CW080500	BC06000	D0400900	GW08000	SS50
MWLN R/L 2525 M08	CW080500	BC06000	D0400900	GW08000	SS50
MWLN R/L 3225 P08	CW080500	BC06000	D0400900	GW08000	SS50
MWLN R/L 3232 P08	CW080500	BC06000	D0400900	GW08000	SS50

(M-K) DOUBLE LOCK SYSTEM

Roughing	Finishing	Medium to Finishing	Medium to Finishing	Medium	Medium
Flat  (08)	MF  (08)	SF  (08)	LC  (08)	MS  (08)	PM  (08)
Medium	Medium	Medium Wiper	Roughing to Medium	Roughing	
MR  (08)	ST  (08)	MW  (08)	SS  (08)	HR  (08)	







Order Code		Reference	Dimensions (mm)					Insert	Kg	Stock	
R	L		H=h	b	L1	L2	S			R	L
212290500	212290600	MWLN R/L 2020 K08-K	20	20	125	34	25	WN.. 0804..	0,450		
212250200	212290700	MWLN R/L 2525 M08-K	25	25	150	34	32	WN.. 0804..	0,800		
212290800	212290900	MWLN R/L 3232 P08-K	32	32	170	34	40	WN.. 0804..	1,400		

 Stock Items | Itens de stock

 Available under request | Disponível sob consulta | Disponible bajo consulta

SPARE PARTS || Complementos | Repuestos





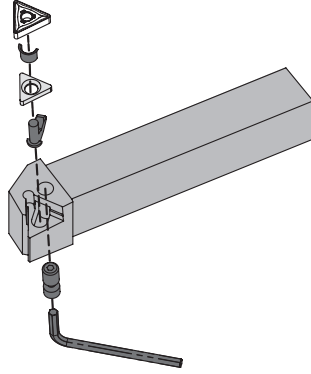







Cutter Reference	Shim 	Lock Pin 	Lock Pin Screw 	Wedge Clamp 	Wrench 
MWLN R/L 2020 K08-K	CW080500	BC06000	D0400900	GW06000	SS25
MWLN R/L 2525 M08-K	CW080500	BC06000	D0400900	GW06000	SS25
MWLN R/L 3232 P08-K	CW080500	BC06000	D0400900	GW06000	SS25

(P) LEVER LOCK SYSTEM









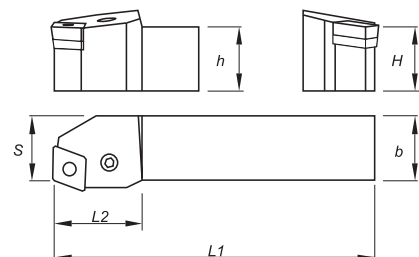
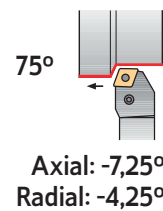













<p>PCBN 75°</p> <p>PAGE C - 563 CN.. 1204.. CN.. 1606.. CN.. 1906.. CN..2509..</p>	<p>PCFN 90°</p> <p>PAGE C - 564 CN.. 1204.. CN.. 1606.. CN.. 1906..</p>	<p>PCKN 75°</p> <p>PAGE C - 565 CN.. 1204... CN.. 1906.. CN.. 2506..</p>	<p>PCLN 95°</p> <p>PAGE C - 566 CN..0903.. ... CN..2509..</p>	<p>PCMN 50°</p> <p>PAGE C - 568 SN.. 1204.. SN.. 1906..</p>	<p>PCSN 45°</p> <p>PAGE C - 569 CN.. 1204.. CN.. 1606.. CN.. 1906..</p>
<p>PDJN 93°</p> <p>PAGE C - 570 DN.. 1104.. DN.. 1504.. DN.. 1506..</p>	<p>PDNN 63°</p> <p>PAGE C - 571 DN.. 1504.. DN.. 1506..</p>	<p>PRDC</p> <p>PAGE C - 572 RC.. 1003M0 ... RC.. 3209M0</p>	<p>PRSC</p> <p>PAGE C - 574 RC.. 10..32</p>	<p>PRSN</p> <p>PAGE C - 575 RN.. 09..25</p>	<p>PSBN 75°</p> <p>PAGE C - 576 SN.. 0903.. ... SN.. 2507..</p>
<p>PSDN 45°</p> <p>PAGE C - 577 SN.. 0903.. ... SN.. 2507..</p>	<p>PSKN 75°</p> <p>PAGE C - 578 SN.. 0903.. ... SN.. 2507..</p>	<p>PSSN 45°</p> <p>PAGE C - 579 SN.. 0903.. ... SN.. 2507..</p>	<p>PTDN 45°</p> <p>PAGE C - 580 TN.. 2204..</p>	<p>PTFN 90°</p> <p>PAGE C - 581 TN.. 1604.. TN.. 2204.. TN.. 2706..</p>	<p>PTGN 90°</p> <p>PAGE C - 582 TN.. 1604.. ... TN.. 3307..</p>
<p>PTTN 60°</p> <p>PAGE C - 583 TN.. 1604.. TN.. 2204..</p>	<p>PWLN 95°</p> <p>PAGE C - 584 WN.. 0604.. WN.. 0804..</p>				

(P) LEVER LOCK TOOLHOLDERS

Roughing	Finishing	Medium to Finishing	Medium to Finishing	Medium	Medium	Medium
Flat  (12-16-19)	MF  (12)	SF  (12)	LC  (12)	MS  (12)	MR  (12-16-19)	PM  (12)
Medium	Roughing to Medium	Roughing	Roughing	Heavy to Roughing	Heavy to Roughing	
ST  (12-16-19)	SS  (12-16-19)	HR  (12-16-19-25)	RP  (16-19)	HY  (19-25)	HZ  (19-25)	



Order Code		Reference	Dimensions (mm)					Insert	Kg	Stock	
R	L		H=h	b	L1	L2	S			R	L
212291000	212291100	PCBN R/L 2020 K12	20	20	125	28	17	CN.. 1204..	0,400		
212011200	212010900	PCBN R/L 2525 M12	25	25	150	28	22	CN.. 1204..	0,750		
212423100	212423200	PCBN R/L 3225 P12	32	25	170	34	22,0	CN.. 1204..	0,750		
212291200	212291300	PCBN R/L 2525 M16	25	25	150	34	22	CN.. 1606..	0,750		
212291400	212291500	PCBN R/L 3225 P16	32	25	170	34	22	CN.. 1606..	1,050		
212291600	212291700	PCBN R/L 3232 P16	32	32	170	34	27	CN.. 1606..	1,300		
212291800	212291900	PCBN R/L 3225 P19	32	25	170	42	22	CN.. 1906..	1,050		
212011300	212011000	PCBN R/L 3232 P19	32	32	170	42	27	CN.. 1906..	1,300		
212011400	212011100	PCBN R/L 4040 S19	40	40	250	45	35	CN.. 1906..	3,050		
212387900	212388000	PCBN R/L 4040 P25	40	40	250	48	41	CN.. 2509..	3,100		
212388100	212388200	PCBN R/L 5050 T25	50	50	300	50	51	CN.. 2509..	4,000		

 Stock Items | Itens de stock













 Available under request | Disponível sob consulta | Disponible bajo consulta

SPARE PARTS | Complementos | Repuestos









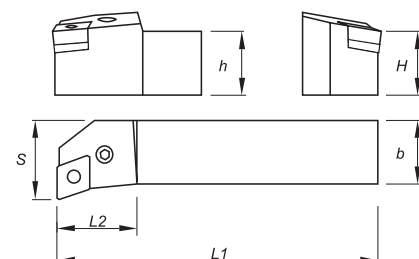
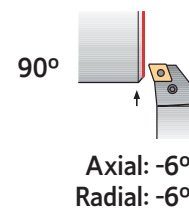





Cutter Reference	Order separately					
	Shim	Shim Pin	Shim Pin Punch	Lever	Lever Screw	Wrench
PCBN R/L 2020 K12						
PCBN R/L 2525 M12	CC120301	BE05500	BF47509	AN13100	PA0802100	SS30
PCBN R/L 3225 P12	CC120301	BE05500	BF47509	AN13100	PA0802100	SS30
PCBN R/L 2525 M16	CC160500	BE07000	BF65012	AN17100	PA0802300	SS30
PCBN R/L 3225 P16	CC160500	BE07000	BF65012	AN17100	PA0802300	SS30
PCBN R/L 3232 P16	CC160500	BE07000	BF65012	AN17100	PA0802300	SS30
PCBN R/L 3225 P19	CC190500	BE08500	BF80012	AN20800	PA1002700	SS40
PCBN R/L 3232 P19	CC190500	BE08500	BF80012	AN20800	PA1002700	SS40
PCBN R/L 4040 S19	CC190500	BE08500	BF80012	AN20800	PA1002700	SS40
PCBN R/L 4040 S25	CC250700	BE10500	BF12520	AN25200	PA1203600	SS50
PCBN R/L 5050 T25	CC250700	BE10500	BF12520	AN25200	PA1203600	SS50

C
 TURNING
 Insert selection
 Overview
 Negative inserts
 Positive inserts
 PCBN & PCD inserts
 Heavy turning
 External Toolholders
 Internal Toolholders
 Automatic Lathes
 Spare Parts
 Technical Data

(P) LEVER LOCK TOOLHOLDERS

Roughing	Finishing	Medium to Finishing	Medium to Finishing	Medium	Medium	Medium
Flat  (12-16-19)	MF  (12)	SF  (12)	LC  (12)	MS  (12)	MR  (12-16-19)	PM  (12)
Medium	Roughing to Medium	Roughing	Roughing	Heavy to Roughing	Heavy to Roughing	
ST  (12-16-19)	SS  (12-16-19)	HR  (12-16-19)	RP  (16-19)	HY  (19)	HZ  (19)	



Order Code		Reference	Dimensions (mm)					Insert	Kg	Stock	
R	L		H=h	b	L1	L2	S			R	L
212292000	212292100	PCFN R/L 2525 M12	25	25	150	28	32	CN..1204..	0,750		
212292200	212292300	PCFN R/L 2525 M16	25	25	150	34	32	CN..1606..	0,750		
212292400	212292500	PCFN R/L 3225 P16	32	25	170	34	32	CN..1606..	1,050		
212292600	212292700	PCFN R/L 3232 P16	32	32	170	34	40	CN..1606..	1,300		
212292800	212292900	PCFN R/L 3225 P19	32	25	170	42	32	CN..1906..	1,050		
212293000	212293100	PCFN R/L 3232 P19	32	32	170	42	40	CN..1906..	1,300		
212293200	212293300	PCFN R/L 4040 S19	40	40	250	45	50	CN..1906..	3,050		













 Stock Items | Itens de stock

 Available under request | Disponível sob consulta | Disponible bajo consulta









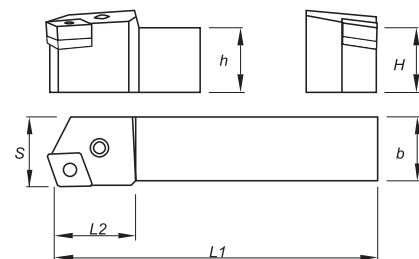
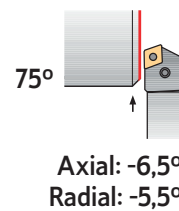





SPARE PARTS | Complementos | Repuestos

Cutter Reference	Order separately					
	Shim	Shim Pin	Shim Pin Punch	Lever	Lever Screw	Wrench
PCFN R/L 2525 M12	 CC120301	 BE05500	 BF47509	 AN13100	 PA0802100	 SS30
PCFN R/L 2525 M16	CC160500	BE07000	BF65012	AN17100	PA0802300	SS30
PCFN R/L 3225 P16	CC160500	BE07000	BF65012	AN17100	PA0802300	SS30
PCFN R/L 3232 P16	CC160500	BE07000	BF65012	AN17100	PA0802300	SS30
PCFN R/L 3225 P19	CC190500	BE08500	BF80012	AN20800	PA1002700	SS40
PCFN R/L 3232 P19	CC190500	BE08500	BF80012	AN20800	PA1002700	SS40
PCFN R/L 4040 S19	CC190500	BE08500	BF80012	AN20800	PA1002700	SS40

(P) LEVER LOCK TOOLHOLDERS

Roughing	Finishing	Medium to Finishing	Medium to Finishing	Medium	Medium	Medium
Flat  (12-19)	MF  (12)	SF  (12)	LC  (12)	MS  (12)	MR  (12-19)	PM  (12)
Medium	Roughing to Medium	Roughing	Roughing	Heavy to Roughing	Heavy to Roughing	
ST  (12-19)	SS  (12-19)	HR  (12-19-25)	RP  (19)	HY  (19-25)	HZ  (19-25)	









Order Code		Reference	Dimensions (mm)					Insert	Kg	Stock	
R	L		H=h	b	L1	L2	S			R	L
212011600	212293400	PCKN R/L 2020 K12	20	20	125	28	25	CN.. 1204..	0,400		
212011700	212293500	PCKN R/L 2525 M12	25	25	150	28	32	CN.. 1204..	0,750		
212293600	212011500	PCKN R/L 3225 P12	32	25	170	28	32	CN.. 1204..	1,050		
212293800	212293900	PCKN R/L 3232 P19	32	32	170	34	40	CN.. 1906..	1,300		
212294000	212294100	PCKN R/L 4040 S19	40	40	250	45	50	CN.. 1906..	3,050		
212294200	212294300	PCKN R/L 4040 S25	40	40	250	45	50	CN.. 2509..	3,050		
212294400	212294500	PCKN R/L 5050 T25	50	50	300	45	60	CN.. 2509..	5,850		

 Stock Items | Itens de stock













 Available under request | Disponível sob consulta | Disponible bajo consulta

SPARE PARTS | Complementos | Repuestos









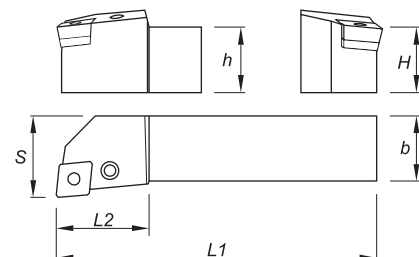
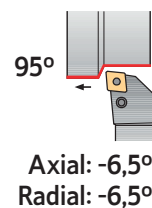





























Cutter Reference	Order separately					
	Shim	Shim Pin	Shim Pin Punch	Lever	Lever Screw	Wrench
PCKN R/L 2020 K12						
PCKN R/L 2525 M12	CC120301	BE05500	BF47509	AN13100	PA0802100	SS30
PCKN R/L 3225 P12	CC120301	BE05500	BF47509	AN13100	PA0802100	SS30
PCKN R/L 3232 P19	CC190500	BE08500	BF80012	AN20800	PA1002700	SS40
PCKN R/L 4040 S19	CC190500	BE08500	BF80012	AN20800	PA1002700	SS40
PCKN R/L 4040 S25	CC250700	BE10500	BF12520	AN25200	PA1203600	SS50
PCKN R/L 5050 T25	CC250700	BE10500	BF12520	AN25200	PA1203600	SS50

C
TURNING
Insert selection
Overview
Negative inserts
Positive inserts
PCBN & PCD inserts
Heavy turning
External Toolholders
Internal Toolholders
Automatic Lathes
Spare Parts
Technical Data

(P) LEVER LOCK TOOLHOLDERS

Roughing	Finishing	Medium to Finishing	Medium to Finishing	Medium	Medium	Medium
Flat  (09-12-16-19)	MF  (09-12)	SF  (12)	LC  (12)	MS  (12)	MR  (09-12-16-19)	PM  (12)
Medium	Roughing to Medium	Roughing	Roughing	Heavy to Roughing	Heavy to Roughing	
ST  (09-12-16-19)	SS  (09-12-16-19)	HR  (12-16-19-25)	RP  (16-19)	HY  (19-25)	HZ  (19-25)	



Order Code		Reference	Dimensions (mm)					Insert	Kg	Stock	
R	L		H=h	b	L1	L2	S			R	L
212294600	212294700	PCLN R/L 1616 H09	16	16	100	25	20	CN.. 0903..	0,250		
212294800	212294900	PCLN R/L 2020 K09	20	20	125	27	25	CN.. 0903..	0,400		
212295000	212295100	PCLN R/L 2525 M09	25	25	150	27	32	CN.. 0903..	0,750		
212012300	212011800	PCLN R/L 1616 H12	16	16	100	26	20	CN.. 1204..	0,250		
212012400	212011900	PCLN R/L 2020 K12	20	20	125	28	25	CN.. 1204..	0,400		
212044800	212031500	PCLN R/L 2525 M12	25	25	150	28	32	CN.. 1204..	0,750		
212295200	212295300	PCLN R/L 3225 P12	32	25	170	28	32	CN.. 1204..	1,050		
212058200	212295400	PCLN R/L 3232 P12	32	32	170	28	40	CN.. 1204..	1,300		
212036400	212168100	PCLN R/L 2525 M16	25	25	150	34	32	CN.. 1606..	0,750		
212295500	212295600	PCLN R/L 3225 P16	32	25	170	34	32	CN.. 1606..	1,050		
212295700	212012100	PCLN R/L 3232 P16	32	32	170	34	40	CN.. 1606..	1,300		
212295800	212012200	PCLN R/L 4040 S16	40	40	250	34	50	CN.. 1606..	3,050		
212058100	212295900	PCLN R/L 2525 M19	25	25	150	42	32	CN.. 1906..	0,750		
212296000	212296100	PCLN R/L 3225 P19	32	25	170	42	32	CN.. 1906..	1,050		
212058300	212296200	PCLN R/L 3232 P19	32	32	170	42	40	CN.. 1906..	1,300		
212058400	212296300	PCLN R/L 4040 S19	40	40	250	45	50	CN.. 1906..	3,050		
212422700	212422800	PCLN R/L 5050 T19	50	50	300	50	60	CN.. 1906..	3,050		
212296400	212296500	PCLN R/L 4040 S25	40	40	250	45	50	CN.. 2509..	3,050		
212296600	212296700	PCLN R/L 5050 T25	50	50	300	45	60	CN.. 2509..	5,850		

 Stock Items | Itens de stock

 Available under request | Disponível sob consulta | Disponible bajo consulta













(P) LEVER LOCK TOOLHOLDERS

SPARE PARTS | Complementos | Repuestos





Cutter Reference	Order separately					
	Shim	Shim Pin	Shim Pin Punch	Lever	Lever Screw	Wrench
PCLN R/L 1616 H09	CC090300	BE04400	BF40009	AN01200	PA0601700	SS25
PCLN R/L 2020 K09	CC090300	BE04400	BF40009	AN01200	PA0601700	SS25
PCLN R/L 2525 M09	CC090300	BE04400	BF40009	AN01200	PA0601700	SS25
PCLN R/L 1616 H12	CC120301	BE05500	BF47509	AC13200	PA0801700	SS30
PCLN R/L 2020 K12	CC120301	BE05500	BF47509	AC13200	PA0802100	SS30
PCLN R/L 2525 M12	CC120301	BE05500	BF47509	AC13200	PA0802100	SS30
PCLN R/L 3225 P12	CC120301	BE05500	BF47509	AC13200	PA0802100	SS30
PCLN R/L 3232 P12	CC120301	BE05500	BF47509	AC13200	PA0802100	SS30
PCLN R/L 2525 M16	CC160500	BE07000	BF65012	AN17100	PA0802300	SS30
PCLN R/L 3225 P16	CC160500	BE07000	BF65012	AN17100	PA0802300	SS30
PCLN R/L 3232 P16	CC160500	BE07000	BF65012	AN17100	PA0802300	SS30
PCLN R/L 4040 S16	CC160500	BE07000	BF65012	AN17100	PA0802300	SS30
PCLN R/L 2525 M19	CC190500	BE08500	BF80012	AN20800	PA1002700	SS40
PCLN R/L 3225 P19	CC190500	BE08500	BF80012	AN20800	PA1002700	SS40
PCLN R/L 3232 P19	CC190500	BE08500	BF80012	AN20800	PA1002700	SS40
PCLN R/L 4040 S19	CC190500	BE08500	BF80012	AN20800	PA1002700	SS40
PCLN R/L 5050 T19	CC190500	BE08500	BF80012	AN20800	PA1002700	SS40
PCLN R/L 4040 S25	CC250700	BE10500	BF12520	AN25200	PA1203600	SS50
PCLN R/L 5050 T25	CC250700	BE10500	BF12520	AN25200	PA1203600	SS50

- TURNING
- Insert selection
- Overview
- Negative inserts
- Positive inserts
- PCBN & PCD inserts
- Heavy turning
- External Toolholders
- Internal Toolholders
- Automatic Lathes
- Spare Parts
- Technical Data

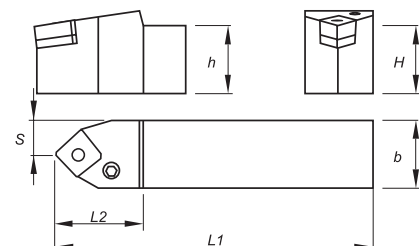
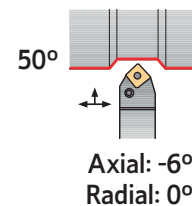
(P) LEVER LOCK TOOLHOLDERS

Roughing	Finishing	Medium to Finishing	Medium to Finishing	Medium	Medium	Medium
Flat  (12-19)	MF  (12)	SF  (12)	LC  (12)	MS  (12)	MR  (12-19)	PM  (12)
Medium	Roughing to Medium	Roughing	Roughing	Heavy to Roughing	Heavy to Roughing	
ST  (12-19)	SS  (12-19)	HR  (12-19)	RP  (19)	HY  (19)	HZ  (19)	









Order Code	Reference	Dimensions (mm)					Insert	Kg	Stock
		H=h	b	L1	L2	s			
212296800	PCMN N 2020 K12	20	20	125	34	10,0	CN.. 1204..	0,400	
212296900	PCMN N 2525 M12	25	25	150	34	12,5	CN.. 1204..	0,750	
212297000	PCMN N 3225 P12	32	25	170	34	12,5	CN.. 1204..	1,050	
212297100	PCMN N 3232 P19	32	32	170	42	16,0	CN.. 1906..	1,300	
212297200	PCMN N 4040 S19	40	40	250	42	20,0	CN.. 1906..	3,050	













 Stock Items | Itens de stock

 Available under request | Disponível sob consulta | Disponible bajo consulta









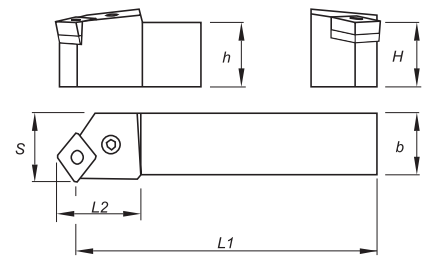
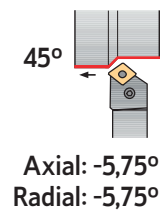







SPARE PARTS | Complementos | Repuestos

Cutter Reference	Order separately					
	Shim	Shim Pin	Shim Pin Punch	Lever	Lever Screw	Wrench
PCMN N 2020 K12						
PCMN N 2525 M12	CC120301	BE05500	BF47509	AN13100	A0802100	SS30
PCMN N 3225 P12	CC120301	BE05500	BF47509	AN13100	A0802100	SS30
PCMN N 3232 P19	CC190500	BE08500	BF80012	AN20800	A1002700	SS40
PCMN N 4040 S19	CC190500	BE08500	BF80012	AN20800	A1002700	SS40

(P) LEVER LOCK TOOLHOLDERS

Roughing	Finishing	Medium to Finishing	Medium to Finishing	Medium	Medium	Medium
Flat  (12-16-19)	MF  (12)	SF  (12)	LC  (12)	MS  (12)	MR  (12-16-19)	PM  (12)
Medium	Roughing to Medium	Roughing	Roughing	Heavy to Roughing	Heavy to Roughing	
ST  (12-19)	SS  (12-16-19)	HR  (12-16-19)	RP  (19)	HY  (19)	HZ  (19)	









Order Code		Reference	Dimensions (mm)					Insert	Kg	Stock	
R	L		H=h	b	L1	L2	S			R	L
212297300	212297400	PCSN R/L 2020 K12	20	20	125	28	25	CN.. 1204..	0,400		
212297500	212012800	PCSN R/L 2525 M12	25	25	150	28	32	CN.. 1204..	0,750		
212297600	212297700	PCSN R/L 2525 M16	25	25	150	34	32	CN.. 1606..	0,750		
212297800	212297900	PCSN R/L 3225 P16	32	25	170	34	32	CN.. 1606..	1,050		
212013100	212298000	PCSN R/L 3232 P16	32	32	170	34	40	CN.. 1606..	1,300		
212298100	212298200	PCSN R/L 3225 P19	32	25	170	42	32	CN.. 1906..	1,050		
212298300	212298400	PCSN R/L 3232 P19	32	32	170	42	40	CN.. 1906..	1,300		
212298500	212298600	PCSN R/L 4040 S19	40	40	250	45	50	CN.. 1906..	3,050		

 Stock Items | Itens de stock















 Available under request | Disponível sob consulta | Disponible bajo consulta

SPARE PARTS | Complementos | Repuestos









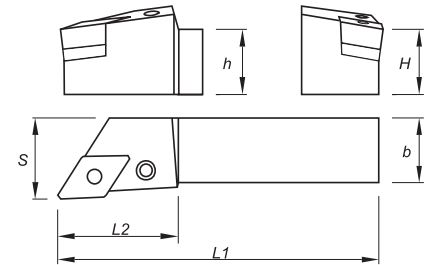
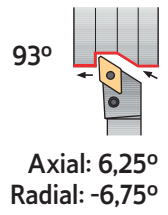











Cutter Reference	Order separately					
	Shim	Shim Pin	Shim Pin Punch	Lever	Lever Screw	Wrench
PCSN R/L 2020 K12						
PCSN R/L 2525 M12	CC120301	BE05500	BF47509	AN13100	PA0802100	SS30
PCSN R/L 2525 M16	CC120301	BE05500	BF47509	AN13100	PA0802100	SS30
PCSN R/L 3225 P16	CC160500	BE07000	BF65012	AN17100	PA0802300	SS30
PCSN R/L 3232 P16	CC160500	BE07000	BF65012	AN17100	PA0802300	SS30
PCSN R/L 3225 P19	CC160500	BE07000	BF65012	AN17100	PA0802300	SS30
PCSN R/L 3232 P19	CC190500	BE08500	BF80012	AN20800	PA1002700	SS40
PCSN R/L 4040 S19	CC190500	BE08500	BF80012	AN20800	PA1002700	SS40

C
TURNING
Insert selection
Overview
Negative inserts
Positive inserts
PCBN & PCD inserts
Heavy turning
External Toolholders
Internal Toolholders
Automatic Lathes
Spare Parts
Technical Data

(P) LEVER LOCK TOOLHOLDERS

Roughing	Finishing	Medium to Finishing	Medium to Finishing	Medium	Medium	Medium	Medium
Flat	MF	SF	LC	MS	MR	PM	ST
 (11-15)	 (11-15)	 (11-15)	 (15)	 (15)	 (11-15)	 (15)	 (11-15)
Medium Wiper	Roughing to Medium	Roughing	Roughing	Roughing to Medium	Medium to Finishing	Medium to Finishing	
MW	SS	HR	RP	O1	O2	O3	
 (15)	 (11-15)	 (15)	 (15)	 (15)	 (15)	 (15)	



Order Code		Reference	Dimensions (mm)					Insert	Kg	Stock	
R	L		H=h	b	L1	L2	S			R	L
212057800	212298700	PDJN R/L 1616 H11	16	16	100	28	20	DN.. 1104..	0,250		
212246900	212246800	PDJN R/L 2020 K11	20	20	125	28	25	DN.. 1104..	0,400		
212247500	212247600	PDJN R/L 2525 M11	25	25	150	28	32	DN.. 1104..	0,750		
212298800	212298900	PDJN R/L 3225 P11	32	25	170	28	32	DN.. 1104..	1,050		
212013600	212013200	PDJN R/L 2020 K15	20	20	125	34	25	DN.. 1506..	0,400		
212037300	212031600	PDJN R/L 2525 M15	25	25	150	34	32	DN.. 1506..	0,750		
212299000	212013400	PDJN R/L 3225 P15	32	25	170	34	32	DN.. 1506..	1,050		
212013800	212013500	PDJN R/L 3232 P15	32	32	170	34	40	DN.. 1506..	1,300		
212299100	212299200	PDJN R/L 4025 R15	40	25	200	34	32	DN.. 1506..	1,850		
212299300	212299400	PDJN R/L 5032 S15	50	32	250	34	40	DN.. 1506..	2,900		















 Stock Items | Itens de stock

 Available under request | Disponível sob consulta | Disponible bajo consulta









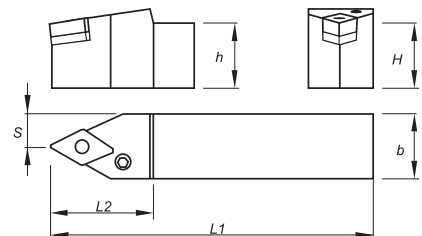
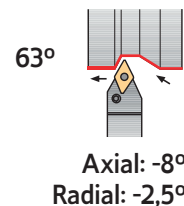









SPARE PARTS || Complementos | Repuestos

Cutter Reference	Order separately						for inserts DN. 1504..	
	Shim	Shim Pin	Shim Pin Punch	Lever	Lever Screw	Wrench	Shim	Shim Pin
PDJN R/L 1616 H11							-	-
PDJN R/L 2020 K11	CD110300	BE04400	BF40009	AN01200	PA0601700	SS25	-	-
PDJN R/L 2525 M11	CD110300	BE04400	BF40009	AN01200	PA0601700	SS25	-	-
PDJN R/L 3225 P11	CD110300	BE04400	BF40009	AN01200	PA0601700	SS25	-	-
PDJN R/L 2020 K15	CD150300	BE05500	BF47509	AN14700	PA0802101	SS30	CD150500	BE05401
PDJN R/L 2525 M15	CD150300	BE05500	BF47509	AN14700	PA0802101	SS30	CD150500	BE05401
PDJN R/L 3225 P15	CD150300	BE05500	BF47509	AN14700	PA0802101	SS30	CD150500	BE05401
PDJN R/L 3232 P15	CD150300	BE05500	BF47509	AN14700	PA0802101	SS30	CD150500	BE05401
PDJN R/L 4025 R15	CD150300	BE05500	BF47509	AN14700	PA0802101	SS30	CD150500	BE05401
PDJN R/L 5032 S15	CD150300	BE05500	BF47509	AN14700	PA0802101	SS30	CD150500	BE05401

(P) LEVER LOCK TOOLHOLDERS

Roughing	Finishing	Medium to Finishing	Medium to Finishing	Medium	Medium	Medium	Medium
Flat	MF	SF	LC	MS	MR	PM	ST
							
(15)	(15)	(15)	(15)	(15)	(15)	(15)	(15)
Medium Wiper	Roughing to Medium	Roughing	Roughing	Roughing to Medium	Medium to Finishing	Medium to Finishing	
MW	SS	HR	RP	O1	O2	O3	
							
(15)	(15)	(15)	(15)	(15)	(15)	(15)	



Order Code		Reference	Dimensions (mm)					Insert	Kg	Stock	
R	L		H=h	b	L1	L2	S			R	L
212299500	212299600	PDNN R/L 2020 K15	20	20	125	34	10,0	DN.. 1506..	0,400		
212299800	212299900	PDNN R/L 2525 M15	25	25	150	34	12,5	DN.. 1506..	0,750		
212300100	212300200	PDNN R/L 3225 P15	32	25	170	34	12,5	DN.. 1506..	1,050		
212300300	212300400	PDNN R/L 3232 P15	32	32	170	34	16,0	DN.. 1506..	1,300		
212300600	212300700	PDNN R/L 4025 S15	40	25	250	34	12,5	DN.. 1506..	1,850		
212300900	212301000	PDNN R/L 5032 S15	50	32	250	34	16,0	DN.. 1506..	2,900		
212299700		PDNN N 2020 K15	20	20	125	34	10,0	DN.. 1506..	0,400		
212300000		PDNN N 2525 M15	25	25	150	34	12,5	DN.. 1506..	0,750		
212250000		PDNN N 3225 P15	32	25	170	34	12,5	DN.. 1506..	1,050		
212300500		PDNN N 3232 P15	32	32	170	34	16,0	DN.. 1506..	1,300		
212300800		PDNN N 4025 S15	40	25	250	34	12,5	DN.. 1506..	1,850		
212301100		PDNN N 5032 S15	50	32	250	34	16,0	DN.. 1506..	2,900		

 Stock items | Itens de stock

 Available under request | Disponível sob consulta | Disponible bajo consulta

SPARE PARTS | Complementos | Repuestos

Cutter Reference	Order separately						for inserts DN.. 1504..	
	Shim	Shim Pin	Shim Pin Punch	Lever	Lever Screw	Wrench	Shim	Shim Pin
PDNN R/L/N 2020 K15								
PDNN R/L/N 2525 M15	CD150300	BE05500	BF47509	AN14700	PA0802101	SS30	CD150500	BE05401
PDNN R/L/N 3225 P15	CD150300	BE05500	BF47509	AN14700	PA0802101	SS30	CD150500	BE05401
PDNN R/L/N 3232 P15	CD150300	BE05500	BF47509	AN14700	PA0802101	SS30	CD150500	BE05401
PDNN R/L/N 4025 S15	CD150300	BE05500	BF47509	AN14700	PA0802101	SS30	CD150500	BE05401
PDNN R/L/N 5032 S15	CD150300	BE05500	BF47509	AN14700	PA0802101	SS30	CD150500	BE05401

(P) LEVER LOCK TOOLHOLDERS

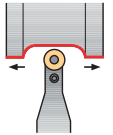

Axial: 0°
Radial: 0°

Roughing to Medium ..MT-ST (10-12-16-20)	Roughing to Medium ..MT-RF (25)	Roughing to Medium ..MT-RM (20)	Roughing to Medium ..MX-ST (10-12-16-20-25-32)
Roughing to Medium ..MX-RM (32)	Roughing to Medium ...MX-RR (25-32)	Finishing to Fine Finishing LN (10-12)	

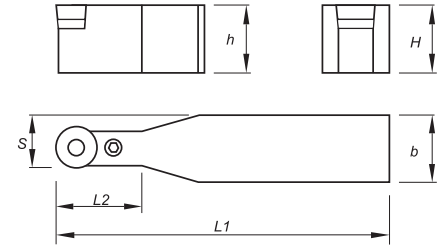

Order Code	Reference	Dimensions (mm)					Insert	Kg	Stock
		H=h	b	L1	L2	S			
212051100	PRDC N 2020 K10	20	20	125	22	15,0	RC.. 1003M0	0,400	⊗
212169000	PRDC N 2525 M10	25	25	150	22	18,5	RC.. 1003M0	0,750	⊗
212301200	PRDC N 3225 P10	32	25	170	22	18,5	RC.. 1003M0	1,050	⊗
212301300	PRDC N 2020 K12	20	20	125	28	16,0	RC.. 1204M0	0,400	⊗
212042800	PRDC N 2525 M12	25	25	150	28	18,5	RC.. 1204M0	0,750	⊗
212301400	PRDC N 3225 P12	32	25	170	28	18,5	RC.. 1204M0	1,050	⊗
212422400	PRDC N 3232 P12	32	32	180	28	22,0	RC.. 1204M0	1,300	○
212301500	PRDC N 4025 S12	40	25	250	28	18,5	RC.. 1204M0	1,850	⊗
212020600	PRDC N 3225 P16	32	25	170	34	20,5	RC.. 1606M0	1,050	⊗
212301600	PRDC N 3232 P16	32	32	170	34	24,0	RC.. 1606M0	1,300	⊗
212301700	PRDC N 3232 P20	32	32	170	42	26,0	RC.. 2006M0	1,300	⊗
212301800	PRDC N 4040 S20	40	40	250	42	30,0	RC.. 2006M0	3,050	⊗
212301900	PRDC N 4040 S25	40	40	250	45	32,5	RC.. 2507M0	3,050	⊗
212293700	PRDC N 4040 U25	40	40	350	45	32,5	RC.. 2507M0	3,050	○
212302000	PRDC N 5050 U25	50	50	350	45	37,5	RC.. 2507M0	5,850	○
212302100	PRDC N 5050 V32	50	50	400	52	41,0	RC.. 3209M0	5,850	○

⊗ Stock Items | Itens de stock

○ Available under request | Disponível sob consulta | Disponible bajo consulta

(P) LEVER LOCK TOOLHOLDERS

SPARE PARTS || Complementos | Repuestos

Cutter Reference	Order separately					
	Shim	Shim Pin	Shim Pin Punch	Lever	Lever Screw	Wrench
PRDC N 2020 K10	CR100300	BE03800	BF40009	AC11700	PA0501400	SS20
PRDC N 2525 M10	CR100300	BE03800	BF40009	AC11700	PA0501400	SS20
PRDC N 3225 P10	CR100300	BE03800	BF40009	AC11700	PA0501400	SS20
PRDC N 2020 K12	CR120300	BE03800	BF40009	AC13300	PA0601700	SS25
PRDC N 2525 M12	CR120300	BE03800	BF40009	AC13300	PA0601700	SS25
PRDC N 3225 P12	CR120300	BE03800	BF40009	AC13300	PA0601700	SS25
PRDC N 3232 P12	CR120300	BE03800	BF40009	AC13300	PA0601700	SS25
PRDC N 4025 S12	CR120300	BE03800	BF40009	AC13300	PA0601700	SS25
PRDC N 3225 P16	CR160500	BE05400	BF47509	AC18000	PA0602100	SS25
PRDC N 3232 P16	CR160500	BE05400	BF47509	AC18000	PA0602100	SS25
PRDC N 3232 P20	CR200500	BE07000	BF65012	AC18700	PA0802400	SS30
PRDC N 4040 S20	CR200500	BE07000	BF65012	AC18700	PA0802400	SS30
PRDC N 4040 S25	CR250600	BE08500	BF80012	AC23000	PA1003000	SS40
PRDC N 4040 U25	CR250600	BE08500	BF80012	AC23000	PA1003000	SS40
PRDC N 5050 U25	CR250600	BE08500	BF80012	AC23000	PA1003000	SS40
PRDC N 5050 V32	CR320600	BE10500	BF12520	AC26700	PA1203600	SS50



TURNING

Insert selection

Overview

Negative inserts

Positive inserts

PCBN & PCD inserts

Heavy turning

External Toolholders

Internal Toolholders

Automatic Lathes

Spare Parts

Technical Data

(P) LEVER LOCK TOOLHOLDERS

Roughing to Medium ..MT-ST (10-12-16-20)	Roughing to Medium ..MT-RF (25)	Roughing to Medium ..MT-RM (20)	Roughing to Medium ..MX-ST (10-12-16-20-25-32)
Roughing to Medium ..MX-RM (32)	Roughing to Medium ..MX-RR (25-32)	Finishing to Fine Finishing LN (10-12)	

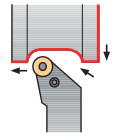

Axial: 0°
Radial: 0°

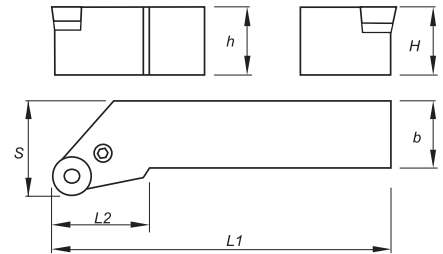

Order Code		Reference	Dimensions (mm)					Insert	Kg	Stock	
R	L		H=h	b	L1	L2	S			R	L
212302200	212302300	PRSC R/L 2020 K10	20	20	125	28	25	RC.. 1003M0	0,400		
212302400	212302500	PRSC R/L 2525 M10	25	25	150	28	32	RC.. 1003M0	0,750		
212302600	212302700	PRSC R/L 3225 P10	32	25	170	28	32	RC.. 1003M0	1,050		
212302800	212302900	PRSC R/L 2020 K12	20	20	125	28	25	RC.. 1204M0	0,400		
212303000	212303100	PRSC R/L 2525 M12	25	25	150	28	32	RC.. 1204M0	0,750		
212303200	212303300	PRSC R/L 3225 P12	32	25	170	28	32	RC.. 1204M0	1,050		
212303500	212303400	PRSC R/L 2525 M16	25	25	150	34	32	RC.. 1606M0	0,750		
212020800	212020700	PRSC R/L 3225 P16	32	25	170	34	32	RC.. 1606M0	1,050		
212303700	212303600	PRSC R/L 3232 P20	32	32	170	42	40	RC.. 2006M0	1,300		
212303900	212303800	PRSC R/L 4040 S20	40	40	250	42	50	RC.. 2006M0	3,050		
212304100	212304000	PRSC R/L 4040 S25	40	40	250	45	50	RC.. 2507M0	3,050		
212020900	212304200	PRSC R/L 5050 T32	50	50	300	45	63	RC.. 3209M0	5,850		



Stock Itens | Itens de stock

Available under request | Disponível sob consulta | Disponible bajo consulta









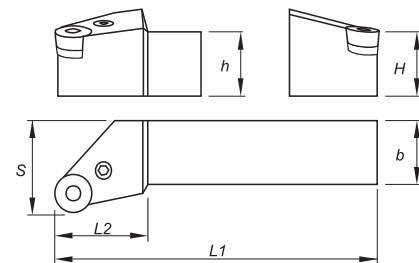
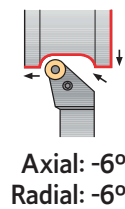

SPARE PARTS | Complementos | Repuestos

Cutter Reference	Order separately					
	Shim	Shim Pin	Shim Pin Punch	Lever	Lever Screw	Wrench
PRSC R/L 2020 K10	CR100300	BE03800	BF40009	AC11700	PA0501400	SS20
PRSC R/L 2525 M10	CR100300	BE03800	BF40009	AC11700	PA0501400	SS20
PRSC R/L 3225 P10	CR100300	BE03800	BF40009	AC11700	PA0501400	SS20
PRSC R/L 2020 K12	CR120300	BE03800	BF40009	AC13300	PA0601700	SS25
PRSC R/L 2525 M12	CR120300	BE03800	BF40009	AC13300	PA0601700	SS25
PRSC R/L 3225 P12	CR120300	BE03800	BF40009	AC13300	PA0601700	SS25
PRSC R/L 2525 M16	CR160500	BE05400	BF47509	AC18000	PA0602100	SS25
PRSC R/L 3225 P16	CR160500	BE05400	BF47509	AC18000	PA0602100	SS25
PRSC R/L 3232 P20	CR200500	BE07000	BF65012	AC18700	PA0802400	SS30
PRSC R/L 4040 S20	CR200500	BE07000	BF65012	AC18700	PA0802400	SS30
PRSC R/L 4040 S25	CR250600	BE08500	BF80012	AC23000	PA0802400	SS40
PRSC R/L 5050 T32	CR320600	BE10500	BF12520	AC26700	PA1203600	SS50

(P) LEVER LOCK TOOLHOLDERS

Roughing to Medium	Roughing to Medium
Flat  (15-25)	ST  (09-12-15-19-25)









Order Code		Reference	Dimensions (mm)					Insert	Kg	Stock	
R	L		H=h	b	L1	L2	S			R	L
212046800	212304300	PRSN R/L 2020 K09	20	20	125	22	25	RNMG 090300	0,400		
212046900	212304400	PRSN R/L 2525 M12	25	25	150	28	32	RNMG 120400	0,750		
212047000	212304500	PRSN R/L 3225 P15	32	25	170	34	32	RNMG 150600	1,050		
212304600	212304700	PRSN R/L 3232 P19	32	32	170	42	40	RNMG 190600	1,300		
212304800	212304900	PRSN R/L 4040 S25	40	40	250	45	50	RNMG 250900	3,050		









 Stock Items | Itens de stock

 Available under request | Disponível sob consulta | Disponible bajo consulta









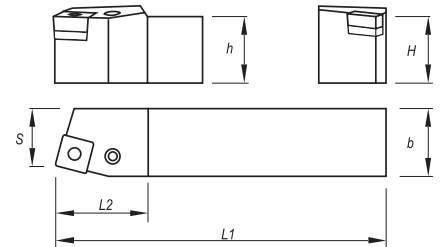
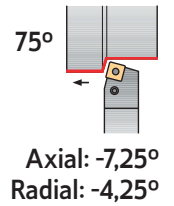

















SPARE PARTS || Complementos | Repuestos

Cutter Reference	Order separately					
	Shim	Shim Pin	Shim Pin Punch	Lever	Lever Screw	Wrench
PRSN R/L 2020 K09						
PRSN R/L 2525 M12	CR090300	BE03800	BF40009	AN01200	PA0601700	SS25
PRSN R/L 3225 P15	CR120302	BE05500	BF47509	AN13100	PA0802100	SS30
PRSN R/L 3232 P19	CR150500	BE07000	BF65012	AN17200	PA0802400	SS30
PRSN R/L 4040 S25	CR190500	BE08500	BF80012	AN20800	PA1002700	SS40
PRSN R/L 4040 S25	CR250601	BE10500	BF12520	AN25200	PA1203600	SS50

(P) LEVER LOCK TOOLHOLDERS

Roughing	Finishing	Medium	Medium	Medium	Medium
Flat  (09-12-15-19-25)	MF  (12)	SF  (12)	MR  (12-15-19)	PM  (12)	ST  (09-12-15-19)
Roughing to Medium	Roughing	Roughing	Heavy to Roughing	Heavy to Roughing	
SS  (09-12-15-19)	HR  (12-15-19-25)	RP  (15-19)	HY  (19-25)	HZ  (19-25)	



Order Code		Reference	Dimensions (mm)					Insert	Kg	Stock	
R	L		H=h	b	L1	L2	S			R	L
212305000	212305100	PSBN R/L 1212 F09	12	12	80	18	11	SN.. 0903..	0,100		
212305200	212305300	PSBN R/L 1616 H09	16	16	100	22	13	SN.. 0903..	0,250		
212305400	212305500	PSBN R/L 2020 K09	20	20	125	22	17	SN.. 0903..	0,400		
212032200	212032300	PSBN R/L 2020 K12	20	20	125	28	17	SN.. 1204..	0,400		
212014300	212032400	PSBN R/L 2525 M12	25	25	150	28	22	SN.. 1204..	0,750		
212305600	212305700	PSBN R/L 3225 P12	32	25	170	28	22	SN.. 1204..	1,050		
212014400	212305800	PSBN R/L 2525 M15	25	25	150	34	22	SN.. 1506..	0,750		
212305900	212306000	PSBN R/L 3232 P15	32	32	170	34	27	SN.. 1506..	1,300		
212306100	212306200	PSBN R/L 3232 P19	32	32	170	42	27	SN.. 1906..	1,300		
212306300	212306400	PSBN R/L 4040 S19	40	40	250	45	35	SN.. 1906..	3,050		
212422500	212422600	PSBN R/L 5050 T19	50	50	300	50	43	SN.. 1906..	3,050		
212306500	212014100	PSBN R/L 4040 S25	40	40	250	45	35	SN.. 2507..	3,050		
212306600	212306700	PSBN R/L 5050 T25	50	50	300	45	43	SN.. 2507..	5,850		











 Stock Items | Itens de stock

 Available under request | Disponível sob consulta | Disponible bajo consulta

SPARE PARTS | Complementos | Repuestos

Cutter Reference	Order separately					
	Shim	Shim Pin	Shim Pin Punch	Lever	Lever Screw	Wrench
PSBN R/L 1212 F09	-	-	-	AN07800	PA0501000	SS20
PSBN R/L 1616 H09	CS090301	BE03800	-	AN01200	PA0601700	SS25
PSBN R/L 2020 K09	CS090301	BE03800	-	AN01200	PA0601700	SS25
PSBN R/L 2020 K12	CS120302	BE05500	BF47509	AN13100	PA0802100	SS30
PSBN R/L 2525 M12	CS120302	BE05500	BF47509	AN13100	PA0802100	SS30
PSBN R/L 3225 P12	CS120302	BE05500	BF47509	AN13100	PA0802100	SS30
PSBN R/L 2525 M15	CS150400	BE07000	BF65012	AN17100	PA0802300	SS30
PSBN R/L 3232 P15	CS150400	BE07000	BF65012	AN17100	PA0802300	SS30
PSBN R/L 3232 P19	CS190400	BE08500	BF80012	AN20800	PA1002700	SS40
PSBN R/L 4040 S19	CS190400	BE08500	BF80012	AN20800	PA1002700	SS40
PSBN R/L 5050 T19	CS190400	BE08500	BF80012	AN20800	PA1002700	SS40
PSBN R/L 4040 S25	CS250600	BE10500	BF12520	AN25200	PA1203600	SS50
PSBN R/L 5050 T25	CS250600	BE10500	BF12520	AN25200	PA1203600	SS50

(P) LEVER LOCK TOOLHOLDERS

Roughing	Finishing	Medium	Medium	Medium	Medium
Flat  (09-12-19-25)	MF  (12)	SF  (12)	MR  (12-19)	PM  (12)	ST  (09-12-19)
Roughing to Medium	Roughing	Roughing	Heavy to Roughing	Heavy to Roughing	
SS  (09-12-19)	HR  (12-19-25)	RP  (19)	HY  (19-25)	HZ  (19-25)	

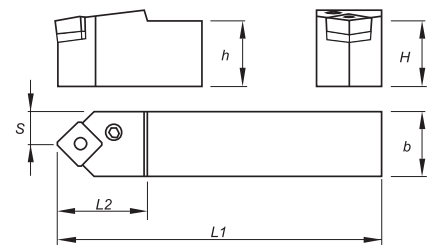
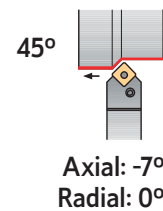

Order Code	Reference	Dimensions (mm)					Insert	Kg	Stock	
		H=h	b	L1	L2	S			R	L
212306800	PSDN N 1010 E09	10	10	70	16	5,0	SN.. 0903..	0,070	⊗	
212306900	PSDN N 1212 F09	12	12	80	18	6,0	SN.. 0903..	0,100	⊗	
212307000	PSDN N 1616 H09	16	16	100	22	8,0	SN.. 0903..	0,250	⊗	
212056700	PSDN N 2020 K12	20	20	125	28	10,0	SN.. 1204..	0,400	⊗	
212307100	PSDN N 2525 M12	25	25	150	28	12,5	SN.. 1204..	0,750	⊗	
212307200	PSDN N 3225 P12	32	25	170	28	12,5	SN.. 1204..	1,050	⊗	
212307300	PSDN N 3232 P12	32	32	170	28	16,0	SN.. 1204..	1,300	⊗	
212307400	PSDN N 3225 P19	32	25	170	42	12,5	SN.. 1906..	1,050	⊗	
212249100	PSDN N 3232 P19	32	32	170	42	16,0	SN.. 1906..	1,300	⊗	
212307500	PSDN N 4040 S25	40	40	250	45	20,0	SN.. 2507..	3,050	⊗	
212307600	PSDN N 5050 T25	50	50	300	45	25,0	SN.. 2507..	5,850	⊗	

⊗ Stock Items | Itens de stock

○ Available under request | Disponível sob consulta | Disponible bajo consulta

SPARE PARTS | Complementos | Repuestos

Cutter Reference	Order separately					
	Shim	Shim Pin	Shim Pin Punch	Lever	Lever Screw	Wrench
PSDN N 1010 E09	-	-	-	AN07800	PA0501000	SS20
PSDN N 1212 F09	-	-	-	AN07800	PA0501000	SS20
PSDN N 1616 H09	CS090301	BE03800	BF40009	AN01200	PA0601700	SS25
PSDN N 2020 K12	CS120302	BE05500	BF47509	AN13100	PA0802100	SS30
PSDN N 2525 M12	CS120302	BE05500	BF47509	AN13100	PA0802100	SS30
PSDN N 3225 P12	CS120302	BE05500	BF47509	AN13100	PA0802100	SS30
PSDN N 3232 P12	CS120302	BE05500	BF47509	AN13100	PA0802100	SS30
PSDN N 3225 P19	CS190400	BE08500	BF80012	AN20800	PA1002700	SS40
PSDN N 3232 P19	CS190400	BE08500	BF80012	AN20800	PA1002700	SS40
PSDN N 4040 S25	CS250600	BE10500	BF12520	AN25200	PA1203600	SS50
PSDN N 5050 T25	CS250600	BE10500	BF12520	AN25200	PA1203600	SS50

TURNING
Insert selection
Overview
Negative inserts
Positive inserts
PCBN & PCD inserts
Heavy turning
External Toolholders
Internal Toolholders
Automatic Lathes
Spare Parts
Technical Data

(P) LEVER LOCK TOOLHOLDERS

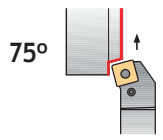

Axial: -4,25°
Radial: -7,25°

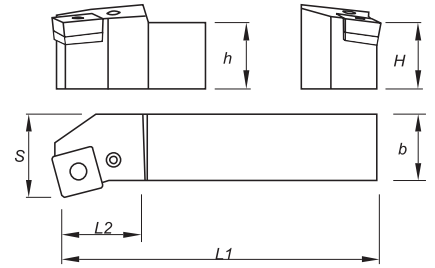

Roughing	Finishing	Medium	Medium	Medium	Medium
Flat (09-12-15-19-25)	MF (12)	SF (12)	MR (12-15-19)	PM (12)	ST (09-12-15-19)
Roughing to Medium	Roughing	Roughing	Heavy to Roughing	Heavy to Roughing	
SS (09-12-15-19)	HR (12-15-19-25)	RP (15-19)	HY (19-25)	HZ (19-25)	

Order Code		Reference	Dimensions (mm)					Insert	Kg	Stock	
R	L		H=h	b	L1	L2	S			R	L
212307700	212307800	PSKN R/L 1616 H09	16	16	100	22	20	SN.. 0903..	0,250		
212307900	212308000	PSKN R/L 2020 K09	20	20	125	22	25	SN.. 0903..	0,400		
212032500	212032600	PSKN R/L 2020 K12	20	20	125	28	25	SN.. 1204..	0,400		
212032700	212032800	PSKN R/L 2525 M12	25	25	150	28	32	SN.. 1204..	0,750		
212308100	212308200	PSKN R/L 3225 P12	32	25	170	28	32	SN.. 1204..	1,050		
212308300	212308400	PSKN R/L 2525 M15	25	25	150	34	32	SN.. 1506..	0,750		
212308500	212308600	PSKN R/L 3232 P15	32	32	170	34	40	SN.. 1506..	1,300		
212308700	212308800	PSKN R/L 3232 P19	32	32	170	42	40	SN.. 1906..	1,300		
212308900	212309000	PSKN R/L 4040 S19	40	40	250	45	50	SN.. 1906..	3,050		
212309100	212309200	PSKN R/L 4040 S25	40	40	250	45	50	SN.. 2507..	3,050		
212309300	212309400	PSKN R/L 5050 T25	50	50	300	45	60	SN.. 2507..	5,850		







Stock Items | Itens de stock

Available under request | Disponível sob consulta | Disponible bajo consulta









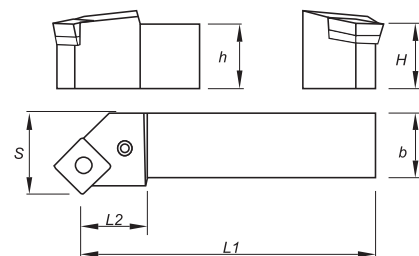
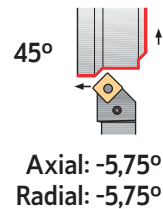

















SPARE PARTS | Complementos | Repuestos

Cutter Reference	Order separately					
	Shim	Shim Pin	Shim Pin Punch	Lever	Lever Screw	Wrench
PSKN R/L 1616 H09	CS090301	BE03800	BF40009	AN01200	PA0601700	SS25
PSKN R/L 2020 K09	CS090301	BE03800	BF40009	AN01200	PA0601700	SS25
PSKN R/L 2020 K12	CS120302	BE05500	BF47509	AN13100	PA0802100	SS30
PSKN R/L 2525 M12	CS120302	BE05500	BF47509	AN13100	PA0802100	SS30
PSKN R/L 3225 P12	CS120302	BE05500	BF47509	AN13100	PA0802100	SS30
PSKN R/L 2525 M15	CS150400	BE07000	BF65012	AN17100	PA0802300	SS30
PSKN R/L 3232 P15	CS150400	BE07000	BF65012	AN17100	PA0802300	SS30
PSKN R/L 3232 P19	CS190400	BE08500	BF80012	AN20800	PA1002700	SS40
PSKN R/L 4040 S19	CS190400	BE08500	BF80012	AN20800	PA1002700	SS40
PSKN R/L 4040 S25	CS250600	BE10500	BF12520	AN25200	PA1203600	SS50
PSKN R/L 5050 T25	CS250600	BE10500	BF12520	AN25200	PA1203600	SS50

(P) LEVER LOCK TOOLHOLDERS

Roughing	Finishing	Medium	Medium	Medium	Medium
Flat	MF	SF	MR	PM	ST
 (09-12-15-19-25)	 (12)	 (12)	 (12-15-19)	 (12)	 (09-12-15-19)
Roughing to Medium	Roughing	Roughing	Heavy to Roughing	Heavy to Roughing	
SS	HR	RP	HY	HZ	
 (09-12-15-19)	 (12-15-19-25)	 (15-19)	 (19-25)	 (19-25)	



Order Code		Reference	Dimensions (mm)					Insert	Kg	Stock	
R	L		H=h	b	L1	L2	S			R	L
212066500	212309500	PSSN R/L 1616 H09	16	16	100	22	20	SN.. 0903..	0,250		
212066600	212309600	PSSN R/L 2020 K09	20	20	125	22	25	SN.. 0903..	0,400		
212032900	212033000	PSSN R/L 2020 K12	20	20	125	28	25	SN.. 1204..	0,400		
212026600	212026700	PSSN R/L 2525 M12	25	25	150	28	32	SN.. 1204..	0,750		
212309700	212309800	PSSN R/L 3225 P12	32	25	170	28	32	SN.. 1204..	1,050		
212066700	212309900	PSSN R/L 2525 M15	25	25	150	34	32	SN.. 1506..	0,750		
212420500	212420600	PSSN R/L 3225 P15	32	25	170	42	32	SN.. 1506..	1,050		
212066800	212015400	PSSN R/L 3232 P15	32	32	170	34	40	SN.. 1506..	1,300		
212066900	212310000	PSSN R/L 3232 P19	32	32	170	42	40	SN.. 1906..	1,300		
212067000	212310100	PSSN R/L 4040 S19	40	40	250	45	50	SN.. 1906..	3,050		
212310200	212310300	PSSN R/L 5050 T19	50	50	300	45	60	SN.. 1906..	5,850		
212310400	212310500	PSSN R/L 4040 S25	40	40	250	45	50	SN.. 2507..	3,050		
212310600	212310700	PSSN R/L 5050 T25	50	50	300	45	60	SN.. 2507..	5,850		

 Stock Items | Itens de stock







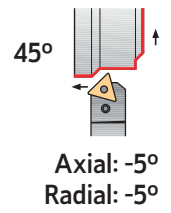

 Available under request | Disponível sob consulta | Disponible bajo consulta

SPARE PARTS | Complementos | Repuestos





Cutter Reference	Order separately					
	Shim	Shim Pin	Shim Pin Punch	Lever	Lever Screw	Wrench
PSSN R/L 1616 H09						
PSSN R/L 2020 K09	CS090301	BE03800	BF40009	AN01200	PA0601700	SS25
PSSN R/L 2020 K12	CS120302	BE05500	BF47509	AN13100	PA0802100	SS30
PSSN R/L 2525 M12	CS120302	BE05500	BF47509	AN13100	PA0802100	SS30
PSSN R/L 3225 P12	CS120302	BE05500	BF47509	AN13100	PA0802100	SS30
PSSN R/L 2525 M15	CS150400	BE07000	BF65012	AN17100	PA0802300	SS30
PSSN R/L 3225 P15	CS150400	BE07000	BF65012	AN17100	PA0802300	SS30
PSSN R/L 3232 P15	CS150400	BE07000	BF65012	AN17100	PA0802300	SS30
PSSN R/L 3232 P19	CS190400	BE08500	BF80012	AN20800	PA1002700	SS40
PSSN R/L 4040 S19	CS190400	BE08500	BF80012	AN20800	PA1002700	SS40
PSSN R/L 5050 T19	CS190400	BE08500	BF80012	AN20800	PA1002700	SS40
PSSN R/L 4040 S25	CS250600	BE10500	BF12520	AN25200	PA1203600	SS50
PSSN R/L 5050 T25	CS250600	BE10500	BF12520	AN25200	PA1203600	SS50

(P) LEVER LOCK TOOLHOLDERS

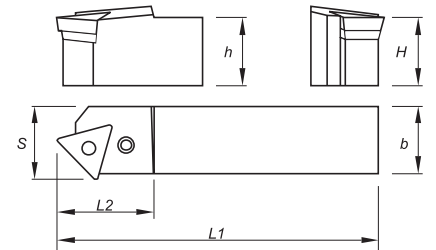

Roughing	Finishing	Medium to Finishing	Medium to Finishing	Medium
Flat	MF	SF	LC	MR
 (22)	 (22)	 (22)	 (22)	 (22)
Medium	Medium	Roughing to Medium	Roughing	
PM	ST	SS	HR	
 (22)	 (22)	 (22)	 (22)	









Order Code		Reference	Dimensions (mm)					Insert	Kg	Stock	
R	L		H=h	b	L1	L2	S			R	L
212310800	212310900	PTDN R/L 2525 M22	25	25	150	34	27	TN.. 2204..	0,750		
212311000	212311100	PTDN R/L 3225 P22	32	25	170	34	27	TN.. 2204..	1,050		











 Stock Items | Itens de stock

 Available under request | Disponível sob consulta | Disponible bajo consulta









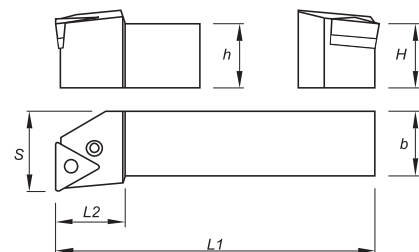
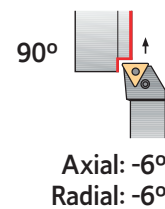









SPARE PARTS | Complementos | Repuestos

Cutter Reference	Order separately					
	Shim	Shim Pin	Shim Pin Punch	Lever	Lever Screw	Wrench
PTDN R/L 2525 M22						
PTDN R/L 2525 M22	CT220302	BE05500	BF47509	AN13100	PA0802100	SS30
PTDN R/L 3225 P22	CT220302	BE05500	BF47509	AN13100	PA0802100	SS30

(P) LEVER LOCK TOOLHOLDERS

Roughing	Finishing	Medium to Finishing	Medium to Finishing	Medium	Medium
Flat	MF	SF	LC	MS	MR
 (16-22-27)	 (16-22)	 (16-22)	 (16-22)	 (16)	 (16-22)
Medium	Medium	Roughing to Medium	Roughing	Medium to Finishing	
PM	ST	SS	HR	O1	
 (16-22)	 (16-22-27)	 (16-22)	 (16-22-27)	 (16)	









Order Code		Reference	Dimensions (mm)					Insert	Kg	Stock	
R	L		H=h	b	L1	L2	S			R	L
212056500	212311200	PTFN R/L 1616 H16	16	16	100	22	20	TN.. 1604..	0,250		
212031700	212015800	PTFN R/L 2020 K16	20	20	125	22	25	TN.. 1604..	0,400		
212036500	212015900	PTFN R/L 2525 M16	25	25	150	22	32	TN.. 1604..	0,750		
212311300	212311400	PTFN R/L 3225 P16	32	25	170	22	32	TN.. 1604..	1,050		
212031800	212311500	PTFN R/L 2525 M22	25	25	150	28	32	TN.. 2204..	0,750		
212016300	212311600	PTFN R/L 3225 P22	32	25	170	28	32	TN.. 2204..	1,050		
212311700	212311800	PTFN R/L 3232 P22	32	32	170	28	40	TN.. 2204..	1,300		
212311900	212312000	PTFN R/L 3232 P27	32	32	170	42	40	TN.. 2706..	1,300		
212312100	212312200	PTFN R/L 4040 S27	40	40	250	45	50	TN.. 2706..	3,050		

 Stock Items | Itens de stock

 Available under request | Disponível sob consulta | Disponible bajo consulta







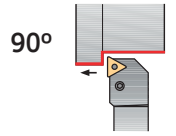



SPARE PARTS | Complementos | Repuestos

Cutter Reference	Order separately					
	Shim	Shim Pin	Shim Pin Punch	Lever	Lever Screw	Wrench
PTFN R/L 1616 H16						
PTFN R/L 2020 K16	CT160303	BE04400	BF40009	AN01200	PA0601700	SS25
PTFN R/L 2525 M16	CT160303	BE04400	BF40009	AN01200	PA0601700	SS25
PTFN R/L 3225 P16	CT160303	BE04400	BF40009	AN01200	PA0601700	SS25
PTFN R/L 2525 M22	CT220302	BE05500	BF47509	AN13100	PA0802100	SS30
PTFN R/L 3225 P22	CT220302	BE05500	BF47509	AN13100	PA0802100	SS30
PTFN R/L 3232 P22	CT220302	BE05500	BF47509	AN13100	PA0802100	SS30
PTFN R/L 3232 P27	CT270500	BE05500	BF65012	AN17200	PA0802400	SS30
PTFN R/L 4040 S27	CT270500	BE05500	BF65012	AN17200	PA0802400	SS30









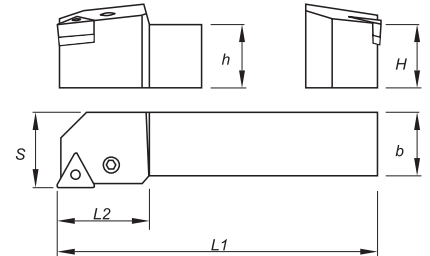













(P) LEVER LOCK TOOLHOLDERS



Axial: -6°
Radial: -6°

Roughing	Finishing	Medium to Finishing	Medium to Finishing	Medium	Medium
Flat	MF	SF	LC	MS	MR
 (16-22-27-33)	 (16-22)	 (16-22)	 (16-22)	 (16)	 (16-22)
Medium	Medium	Roughing to Medium	Roughing	Medium to Finishing	
PM	ST	SS	HR	O1	
 (16-22)	 (16-22-27-33)	 (16-22)	 (16-22-27-33)	 (16)	



Order Code		Reference	Dimensions (mm)					Insert	Kg	Stock	
R	L		H=h	b	L1	L2	S			R	L
212052700	212312300	PTGN R/L 1616 H16	16	16	100	22	20	TN.. 1604..	0,250		
212031900	212016500	PTGN R/L 2020 K16	20	20	125	22	25	TN.. 1604..	0,400		
212026500	212037400	PTGN R/L 2525 M16	25	25	150	22	32	TN.. 1604..	0,750		
212312400	212312500	PTGN R/L 3225 P16	32	25	170	22	32	TN.. 1604..	1,050		
212032000	212032100	PTGN R/L 2525 M22	25	25	150	28	32	TN.. 2204..	0,750		
212312600	212312700	PTGN R/L 3225 P22	32	25	170	28	32	TN.. 2204..	1,050		
212058500	212312800	PTGN R/L 3232 P22	32	32	170	28	40	TN.. 2204..	1,300		
212058600	212312900	PTGN R/L 4040 S22	40	40	250	34	50	TN.. 2204..	3,050		
212066100	212313000	PTGN R/L 3232 P27	32	32	170	42	40	TN.. 2706..	1,300		
212313100	212313200	PTGN R/L 4040 S27	40	40	250	45	50	TN.. 2706..	3,050		
212250300	212313300	PTGN R/L 5050 T33	50	50	300	45	60	TN.. 3307..	5,850		











 Stock Items | Itens de stock

 Available under request | Disponível sob consulta | Disponible bajo consulta









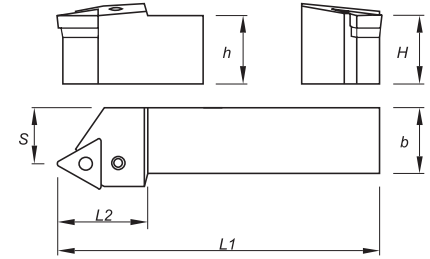
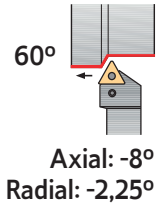

SPARE PARTS | Complementos | Repuestos

Cutter Reference	Order separately					
	Shim	Shim Pin	Shim Pin Punch	Lever	Lever Screw	Wrench
PTGN R/L 1616 H16						
PTGN R/L 2020 K16	CT160303	BE04400	BF40009	AN01200	PA0601700	SS25
PTGN R/L 2525 M16	CT160303	BE04400	BF40009	AN01200	PA0601700	SS25
PTGN R/L 3225 P16	CT160303	BE04400	BF40009	AN01200	PA0601700	SS25
PTGN R/L 2525 M22	CT220302	BE05500	BF47509	AN13100	PA0802100	SS30
PTGN R/L 3225 P22	CT220302	BE05500	BF47509	AN13100	PA0802100	SS30
PTGN R/L 3232 P22	CT220302	BE05500	BF47509	AN13100	PA0802100	SS30
PTGN R/L 4040 S22	CT220302	BE05500	BF47509	AN13100	PA0802100	SS30
PTGN R/L 3232 P27	CT270500	BE07000	BF65012	AN17200	PA0802400	SS30
PTGN R/L 4040 S27	CT270500	BE07000	BF65012	AN17200	PA0802400	SS30
PTGN R/L 5050 T33	CT330500	BE08301	BF80012	AN20800	PA1002700	SS40

(P) LEVER LOCK TOOLHOLDERS

Roughing	Finishing	Medium to Finishing	Medium to Finishing	Medium	Medium
Flat	MF	SF	LC	MS	MR
 (16-22)	 (16-22)	 (16-22)	 (16-22)	 (16)	 (16-22)
Medium	Medium	Roughing to Medium	Roughing	Medium to Finishing	
PM	ST	SS	HR	O1	
 (16-22)	 (16-22)	 (16-22)	 (16-22)	 (16)	









Order Code		Reference	Dimensions (mm)					Insert	Kg	Stock	
R	L		H=h	b	L1	L2	S			R	L
212313400	212313500	PTTN R/L 1616 H16	16	16	100	25	13	TN.. 1604..	0,250		
212313600	212313700	PTTN R/L 2020 K16	20	20	125	28	17	TN.. 1604..	0,400		
212313800	212313900	PTTN R/L 2525 M16	25	25	150	28	22	TN.. 1604..	0,750		
212314000	212314100	PTTN R/L 2525 M22	25	25	150	34	22	TN.. 2204..	0,750		
212314200	212314300	PTTN R/L 3225 P22	32	25	170	34	22	TN.. 2204..	1,050		

 Stock Items | Itens de stock











 Available under request | Disponível sob consulta | Disponible bajo consulta

SPARE PARTS | Complementos | Repuestos









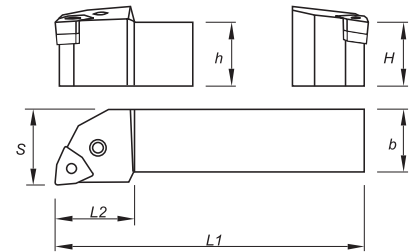
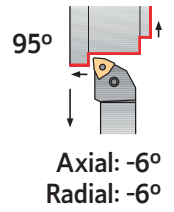





Cutter Reference	Order separately					
	Shim	Shim Pin	Shim Pin Punch	Lever	Lever Screw	Wrench
PTTN R/L 1616 H16						
PTTN R/L 2020 K16	CT160303	BE04400	BF40009	AN01200	PA0601700	SS25
PTTN R/L 2525 M16	CT160303	BE04400	BF40009	AN01200	PA0601700	SS25
PTTN R/L 2525 M22	CT220302	BE05500	BF47509	AN13100	PA0802100	SS30
PTTN R/L 3225 P22	CT220302	BE05500	BF47509	AN13100	PA0802100	SS30

C
TURNING
Insert selection
Overview
Negative inserts
Positive inserts
PCBN & PCD inserts
Heavy turning
External Toolholders
Internal Toolholders
Automatic Lathes
Spare Parts
Technical Data

(P) LEVER LOCK TOOLHOLDERS

Roughing	Finishing	Medium to Finishing	Medium to Finishing	Medium	Medium
Flat  (08)	MF  (06-08)	SF  (06-08)	LC  (08)	MS  (06-08)	PM  (08)
Medium	Medium	Medium Wiper	Roughing to Medium	Roughing	
MR  (06-08)	ST  (08)	MW  (06-08)	SS  (06-08)	HR  (08)	













































Order Code		Reference	Dimensions (mm)					Insert	Kg	Stock	
R	L		H=h	b	L1	L2	S			R	L
212314400	212314500	PWLN R/L 1616 H06	16	16	100	15	20	WN.. 0604..	0,250		
212314600	212046500	PWLN R/L 2020 K06	20	20	125	25	25	WN.. 0604..	0,400		
212314700	212314800	PWLN R/L 2525 M06	25	25	150	25	32	WN.. 0604..	0,750		
212049300	212314900	PWLN R/L 2020 K08	20	20	125	34	25	WN.. 0804..	0,400		
212052800	212079100	PWLN R/L 2525 M08	25	25	150	34	32	WN.. 0804..	0,750		
212046600	212315000	PWLN R/L 3225 P08	32	25	170	34	32	WN.. 0804..	1,050		
212058000	212315100	PWLN R/L 3232 P08	32	32	170	34	40	WN.. 0804..	1,300		

 Stock Items | Itens de stock

 Available under request | Disponível sob consulta | Disponible bajo consulta

SPARE PARTS || Complementos | Repuestos





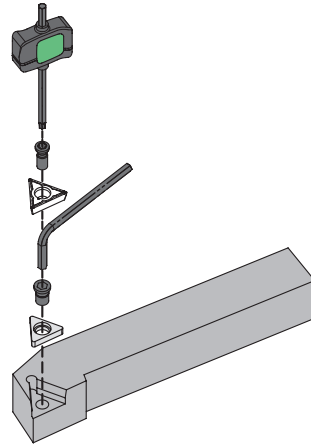





Cutter Reference	Order separately					
	Shim	Shim Pin	Shim Pin Punch	Lever	Lever Screw	Wrench
PWLN R/L 1616 H06	 CW060301	 BE04400	 BF40009	 AN01200	 PA0601700	 SS25
PWLN R/L 2020 K06	 CW060301	 BE04400	 BF40009	 AN01200	 PA0601700	 SS25
PWLN R/L 2525 M06	 CW060301	 BE04400	 BF40009	 AN01200	 PA0601700	 SS25
PWLN R/L 2020 K08	 CW080300	 BE05500	 BF47509	 AN13100	 PA0802100	 SS30
PWLN R/L 2525 M08	 CW080300	 BE05500	 BF47509	 AN13100	 PA0802100	 SS30
PWLN R/L 3225 P08	 CW080300	 BE05500	 BF47509	 AN13100	 PA0802100	 SS30
PWLN R/L 3232 P08	 CW080300	 BE05500	 BF47509	 AN13100	 PA0802100	 SS30

(S) CENTER SCREW SYSTEM









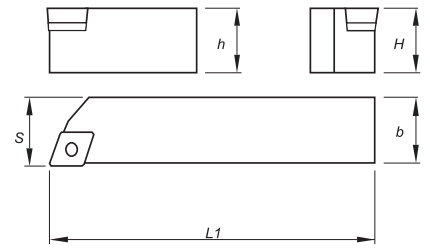
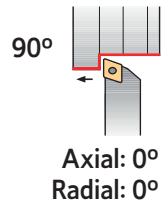





SCAC 90° PAGE C - 586 CC.. 0602.. CC.. 09T3.. CC.. 1204..	SCLC 95° PAGE C - 587 CC.. 0602.. CC.. 09T3.. CC.. 1204..	SDJC 93° PAGE C - 588 DC.. 0702.. DC.. 11T3..	SDNC 62°30' PAGE C - 589 DC.. 0702.. DC.. 11T3..	SRDC PAGE C - 590 RC.. 0602M0.. ... RC.. 1204M0..	SSBC 75° PAGE C - 591 SC.. 09T3.. SC.. 1204..
SSDC 45° PAGE C - 592 SC.. 09T3.. SC.. 1204..	SSSC 45° PAGE C - 593 SC.. 09T3.. SC.. 1204..	STAC 90° PAGE C - 594 TC.. 0902.. TC.. 1102.. TC.. 16T3..	STDC 45° PAGE C - 595 TC.. 0902.. TC.. 1102.. TC.. 16T3..	STFC 90° PAGE C - 596 TC.. 0902.. TC.. 1102.. TC.. 16T3..	STGC 90° PAGE C - 597 TC.. 0902.. TC.. 1102.. TC.. 16T3..
STJC 93° PAGE C - 598 TC.. 0902.. TC.. 1102.. TC.. 16T3..	STTC 60° PAGE C - 599 TC.. 0902.. TC.. 1102.. TC.. 16T3..	SVHC 107°30' PAGE C - 600 VC.. 1604..	SVJB 93° PAGE C - 601 VB.. 1604..	SVJC 93° PAGE C - 602 VC.. 1103.. VC.. 1604..	SVLC 95° PAGE C - 603 VC.. 1303..
SVVB 72°30' PAGE C - 604 VB.. 1604..	SVVC 72°30' PAGE C - 605 VC.. 1103.. VC.. 1604..	SVXC 113° PAGE C - 606 VC.. 1803..	SVZC 100° PAGE C - 607 VC.. 1604..		

(S) CENTER SCREW TOOLHOLDERS

Finishing	Finishing	Finishing	Finishing	Finishing	Finishing wiper	Medium to Finishing
Flat  (06-09-12)	FP  (06-09-12)	BO  (06-09-12)	FM  (06-09-12)	FK  (06-09-12)	FW  (06-09)	LM  (06-09-12)
Medium	Medium	Medium	Medium to Finishing wiper	Finishing to Fine finishing	Medium to Finishing	
MP  (06-09-12)	MM  (06-09-12)	MK  (06-09-12)	MW  (06-09-12)	FS  (06-09)	LN  (06-09-12)	







Order Code		Reference	Dimensions (mm)				Insert	Kg	Stock	
R	L		H=h	b	L1	S			R	L
212139500	212139400	SCAC R/L 0808 D06	8	8	60	8,5	CC.. 0602..	0,050		
212139700	212139600	SCAC R/L 1010 E06	10	10	70	10,5	CC.. 0602..	0,070		
212139900	212139800	SCAC R/L 1212 F09	12	12	80	12,5	CC.. 09T3..	0,100		
212140100	212140000	SCAC R/L 1616 H09	16	16	100	16,5	CC.. 09T3..	0,200		
212140300	212140200	SCAC R/L 2020 K12	20	20	125	20,5	CC.. 1204..	0,400		
212140500	212140400	SCAC R/L 2525 M12	25	25	150	25,5	CC.. 1204..	0,700		





 Stock Items | Itens de stock

Available under request | Disponível sob consulta | Disponible bajo consulta









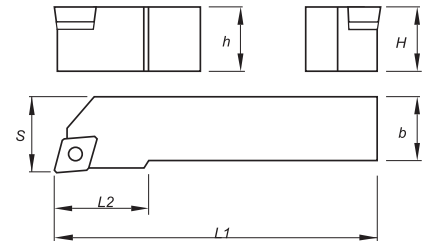
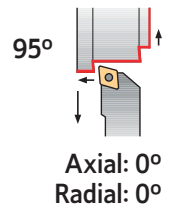





SPARE PARTS || Complementos | Repuestos

Cutter Reference	Shim 	Shim Screw 	Screw 	Wrench 
SCAC R/L 0808 D06	-	-	P0250700	XT07
SCAC R/L 1010 E06	-	-	P0250700	XT07
SCAC R/L 1212 F09	-	-	P0401100	XT15-S35
SCAC R/L 1616 H09	-	-	P0401100	XT15-S35
SCAC R/L 2020 K12	CC120401	T06004000	P0401400	XT15-S40
SCAC R/L 2525 M12	CC120401	T06004000	P0401400	XT15-S40

(S) CENTER SCREW TOOLHOLDERS

Finishing Flat  (06-09-12)	Finishing FP  (06-09-12)	Finishing BO  (06-09-12)	Finishing FM  (06-09-12)	Finishing FK  (06-09-12)	Finishing wiper FW  (06-09)	Medium to Finishing LM  (06-09-12)
Medium MP  (06-09-12)	Medium MM  (06-09-12)	Medium MK  (06-09-12)	Medium to Finishing wiper MW  (06-09-12)	Finishing to Fine finishing FS  (06-09)	Medium to Finishing LN  (06-09-12)	







Order Code		Reference	Dimensions (mm)					Insert	Kg	Stock	
R	L		H=h	b	L1	L2	S			R	L
212140700	212140600	SCLC R/L 0808 D06	8	8	60	10	10	CC.. 0602..	0,050		
212045400	212140800	SCLC R/L 1010 E06	10	10	70	10	12	CC.. 0602..	0,070		
212037100	212140900	SCLC R/L 1212 F09	12	12	80	16	16	CC.. 09T3..	0,100		
212047600	212141000	SCLC R/L 1616 H09	16	16	100	16	20	CC.. 09T3..	0,200		
212037500	212141100	SCLC R/L 2020 K09	20	20	125	16	25	CC.. 09T3..	0,400		
212037700	212141200	SCLC R/L 2020 K12	20	20	125	25	25	CC.. 1204..	0,400		
212037900	212141300	SCLC R/L 2525 M12	25	25	150	25	32	CC.. 1204..	0,700		

 Stock Items | Itens de stock

 Available under request | Disponível sob consulta | Disponible bajo consulta







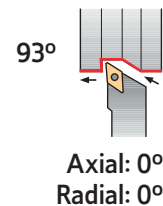

SPARE PARTS | Complementos | Repuestos

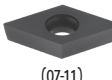
Cutter Reference	Shim 	Shim Screw 	Screw 	Wrench 
SCLC R/L 0808 D06	-	-	P0250700	XT07
SCLC R/L 1010 E06	-	-	P025070	XT07
SCLC R/L 1212 F09	-	-	P0401100	XT15-S35
SCLC R/L 1616 H09	-	-	P0401100	XT15-S35
SCLC R/L 2020 K09	-	-	P0401100	XT15-S35
SCLC R/L 2020 K12	CC120401	T06004000	P0401400	XT15-S40
SCLC R/L 2525 M12	CC120401	T06004000	P0401400	XT15-S40



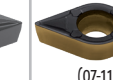
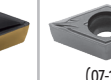



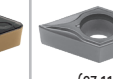
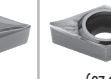

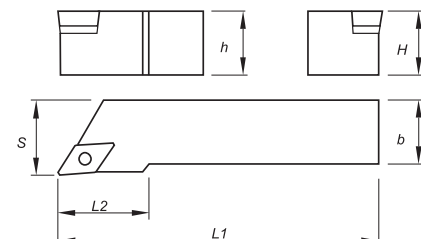





C
TURNING
Insert selection
Overview
Negative inserts
Positive inserts
PCBN & PCD inserts
Heavy turning
External Toolholders
Internal Toolholders
Automatic Lathes
Spare Parts
Technical Data

(S) CENTER SCREW TOOLHOLDERS







Finishing	Finishing	Finishing	Finishing	Finishing wiper	Medium to Finishing
Flat	FP	FM	FK	FW	LM
 (07-11)	 (07-11)	 (07-11)	 (07-11)	 (07-11)	 (07-11)
Medium	Medium	Medium	Medium to Finishing wiper	Finishing to Fine Finishing	Finishing to Fine Finishing
MP	MM	MK	MW	FS	LN
 (07-11)	 (07-11)	 (07-11)	 (11)	 (07-11)	 (07-11)











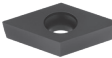

Order Code		Reference	Dimensions (mm)					Insert	Kg	Stock	
R	L		H=h	b	L1	L2	S			R	L
212143800	212143700	SDJC R/L 1010 E07	10	10	70	16	12	DC.. 0702..	0,070		
212021500	212143900	SDJC R/L 1212 F07	12	12	80	18	16	DC.. 0702..	0,100		
212420700	212420800	SDJC R/L 1616 H07	16	16	100	16	20	DC.. 0702..	0,150		
212021600	212144000	SDJC R/L 1212 F11	12	12	80	18	16	DC.. 11T3..	0,100		
212035100	212035200	SDJC R/L 1616 H11	16	16	100	22	20	DC.. 11T3..	0,200		
212036200	212035300	SDJC R/L 2020 K11	20	20	125	22	25	DC.. 11T3..	0,400		
212042600	212144100	SDJC R/L 2525 M11	25	25	150	22	32	DC.. 11T3..	0,700		

 Stock Items | Itens de stock  Available under request | Disponível sob consulta | Disponible bajo consulta

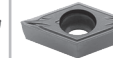



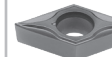

SPARE PARTS || Complementos | Repuestos

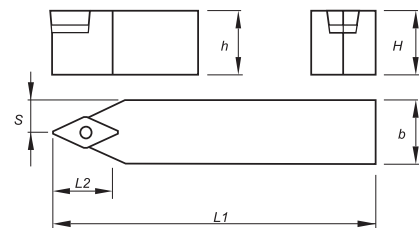
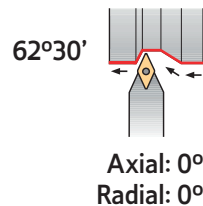
Cutter Reference	Shim	Shim Screw	Screw	Wrench
SDJC R/L 1010 E07				
SDJC R/L 1212 F07	-	-	P0250700	XT07
SDJC R/L 1616 H07	-	-	P0250700	XT07
SDJC R/L 1212 F11	-	-	P0401100	XT15-S35
SDJC R/L 1616 H11	CD110301	T05003500	P0351500	XT15-S35
SDJC R/L 2020 K11	CD110301	T05003500	P0351500	XT15-S35
SDJC R/L 2525 M11	CD110301	T05003500	P0351500	XT15-S35

(S) CENTER SCREW TOOLHOLDERS

Finishing	Finishing	Finishing	Finishing	Medium to Finishing
Flat	FP	FM	FK	LM
 (07-11)	 (07-11)	 (07-11)	 (07-11)	 (07-11)
Medium	Medium	Medium	Finishing to Fine Finishing	Finishing to Fine Finishing
MP	MM	MK	FS	LN
 (07-11)	 (07-11)	 (07-11)	 (07-11)	 (07-11)







Order Code	Reference	Dimensions (mm)					Insert	Kg	Stock
		H=h	b	L1	L2	S			
212144200	SDNC N 0808 D07	8	8	60	16	4,0	DC.. 0702..	0,050	
212144300	SDNC N 1010 E07	10	10	70	16	5,0	DC.. 0702..	0,070	
212144400	SDNC N 1212 F07	12	12	80	18	6,0	DC.. 0702..	0,100	
212259700	SDNC N 1616 H11	16	16	100	22	8,0	DC.. 11T3..	0,200	
212144500	SDNC N 2020 K11	20	20	125	22	10,0	DC.. 11T3..	0,400	
212259800	SDNC N 2525 M11	25	25	150	22	12,5	DC.. 11T3..	0,700	

 Stock Items | Itens de stock

 Available under request | Disponible sob consulta | Disponible bajo consulta



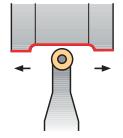

SPARE PARTS || Complementos | Repuestos

Cutter Reference	Shim	Shim Screw	Screw	Wrench
SDNC N 0808 D07	 -	 -	 P0250700	 XT07
SDNC N 1010 E07	-	-	P0250700	XT07
SDNC N 1212 F07	-	-	P0250700	XT07
SDNC N 1616 H11	CD110301	T05003500	P0351500	XT15-S35
SDNC N 2020 K11	CD110301	T05003500	P0351500	XT15-S35
SDNC N 2525 M11	CD110301	T05003500	P0351500	XT15-S35

(S) CENTER SCREW TOOLHOLDERS



Axial: 0°
Radial: 0°

Medium	Roughing to Medium	Roughing to Medium	Finishing to Fine Finishing
CP  (06)	..MT-ST  (08-10-12)	..MX-ST  (12)	LN  (06-08-12)

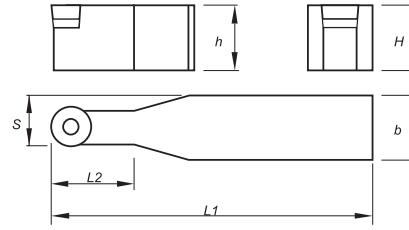

Order Code	Reference	Dimensions (mm)					Insert	Kg	Stock
		H=h	b	L1	L2	S			
212148500	SRDC N 1010 E06	10	10	70	10	8,0	RC.. 0602M0	0,070	⊗
212148600	SRDC N 1212 F06	12	12	80	12	11,0	RC.. 0602M0	0,100	⊗
212058700	SRDC N 1616 H06	16	16	100	16	13,0	RC.. 0602M0	0,200	⊗
212053400	SRDC N 2020 K06	20	20	125	20	15,0	RC.. 0602M0	0,400	⊗
212040000	SRDC N 2525 M06	25	25	150	25	17,5	RC.. 0602M0	0,700	⊗
212148700	SRDC N 1616 H08	16	16	100	16	13,0	RC.. 0803M0	0,200	⊗
212024400	SRDC N 2020 K08	20	20	125	20	15,0	RC.. 0803M1	0,400	⊗
212148800	SRDC N 2525 M08	25	25	150	25	17,5	RC.. 0803M2	0,700	⊗
212049500	SRDC N 2020 K10	20	20	125	22	15,0	RC.. 10T3M0	0,400	⊗
212040100	SRDC N 2525 M10	25	25	150	22	17,5	RC.. 10T3M0	0,700	⊗
212259900	SRDC N 2020 K12	20	20	125	28	16,0	RC.. 1204M0	0,400	⊗
212050800	SRDC N 2525 M12	25	25	150	28	18,5	RC.. 1204M0	0,700	⊗
212058800	SRDC N 3225 P12	32	25	170	28	18,5	RC.. 1204M0	0,900	⊗
212148900	SRDC N 3232 P12	32	32	170	28	22,0	RC.. 1204M0	1,200	⊗









⊗ Stock Items | Itens de stock

○ Available under request | Disponível sob consulta | Disponible bajo consulta







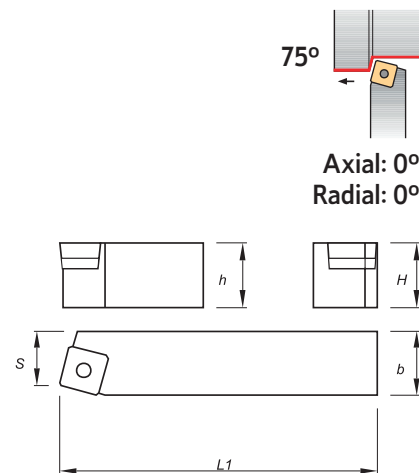

SPARE PARTS || Complementos | Repuestos

Cutter Reference	Shim	Shim Screw	Screw	Wrench
SRDC N 1010 E06	-	-	P0250700	XT07
SRDC N 1212 F06	-	-	P0250700	XT07
SRDC N 1616 H06	-	-	P0250700	XT07
SRDC N 2020 K06	-	-	P0250700	XT07
SRDC N 2525 M06	-	-	P0250700	XT07
SRDC N 1616 H08	-	-	P0300900	XT08
SRDC N 2020 K08	-	-	P0300900	XT08
SRDC N 2525 M08	-	-	P0300900	XT08
SRDC N 2020 K10	CR100301	T05003500	P0351500	XT15-S35
SRDC N 2525 M10	CR100301	T05003500	P0351500	XT15-S35
SRDC N 2020 K12	CR120301	T05003500	P0351500	XT15-S35
SRDC N 2525 M12	CR120301	T05003500	P0351500	XT15-S35
SRDC N 3225 P12	CR120301	T05003500	P0351500	XT15-S35
SRDC N 3232 P12	CR120301	T05003500	P0351500	XT15-S35

(S) CENTER SCREW TOOLHOLDERS

Finishing	Finishing	Finishing	Finishing
Flat  (09-12)	FP  (09)	FM  (09)	FK  (09)
Medium	Medium	Medium	Medium to Finishing
MP  (09-12)	MM  (09-12)	MK  (09-12)	LN  (09-12)







Order Code		Reference	Dimensions (mm)				Insert	Kg	Stock	
R	L		H=h	b	L1	S			R	L
212149100	212149000	SSBC R/L 1212 F09	12	12	80	11	SC.. 09T3..	0,100		
212045700	212149200	SSBC R/L 1616 H09	16	16	100	13	SC.. 09T3..	0,200		
212149400	212149300	SSBC R/L 2020 K12	20	20	125	17	SC.. 1204..	0,400		
212149600	212149500	SSBC R/L 2525 M12	25	25	150	22	SC.. 1204..	0,700		

 Stock Items | Itens de stock

 Available under request | Disponivel sob consulta | Disponible bajo consulta







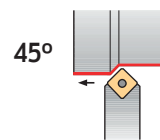

SPARE PARTS || Complementos | Repuestos

Cutter Reference	Shim 	Shim Screw 	Screw 	Wrench 
SSBC R/L 1212 F09	-	-	P0401100	XT15-S35
SSBC R/L 1616 H09	-	-	P0401100	XT15-S35
SSBC R/L 2020 K12	CS120400	T06004000	P0401400	XT15-S40
SSBC R/L 2525 M12	CS120400	T06004000	P0401400	XT15-S40





(S) CENTER SCREW TOOLHOLDERS

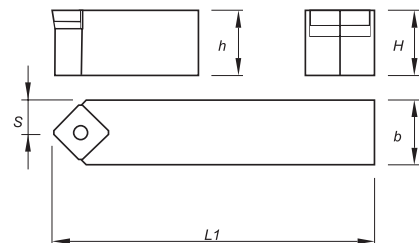

Axial: 0°
Radial: 0°

Finishing	Finishing	Finishing	Finishing
Flat  (09-12)	FP  (09)	FM  (09)	FK  (09)
Medium	Medium	Medium	Medium to Finishing
MP  (09-12)	MM  (09-12)	MK  (09-12)	LN  (09-12)







Order Code	Reference	Dimensions (mm)				Insert	Kg	Stock
		H=h	b	L1	S			
212149700	SSDC N 1212 F09	12	12	80	6,0	SC.. 09T3..	0,100	
212050900	SSDC N 1616 H09	16	16	100	8,0	SC.. 09T3..	0,200	
212046000	SSDC N 2020 K12	20	20	125	10,0	SC.. 1204..	0,400	
212076800	SSDC N 2525 M12	25	25	150	12,5	SC.. 1204..	0,700	









 Stock Items | Itens de stock

 Available under request | Disponível sob consulta | Disponible bajo consulta







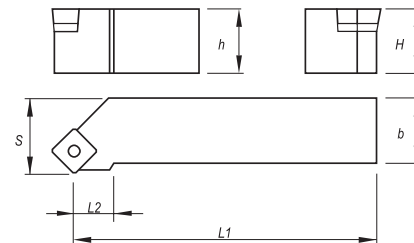
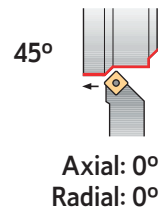

SPARE PARTS || Complementos | Repuestos

Cutter Reference	Shim 	Shim Screw 	Screw 	Wrench 
SSDC N 1212 F09	-	-	P0401100	XT15-S35
SSDC N 1616 H09	-	-	P0401100	XT15-S35
SSDC N 2020 K12	CS120400	T06004000	P0401400	XT15-S40
SSDC N 2525 M12	CS120400	T06004000	P0401400	XT15-S40

(S) CENTER SCREW TOOLHOLDERS

Finishing	Finishing	Finishing	Finishing
Flat	FP	FM	FK
 (09-12)	 (09)	 (09)	 (09)
Medium	Medium	Medium	Medium to Finishing
MP	MM	MK	LN
 (09-12)	 (09-12)	 (09-12)	 (09-12)







Order Code		Reference	Dimensions (mm)					Insert	Kg	Stock	
R	L		H=h	b	L1	L2	S			R	L
212149900	212149800	SSSC R/L 1212 F09	12	12	80	11	16	SC.. 09T3..	0,100		
212150100	212150000	SSSC R/L 1616 H09	16	16	100	22	20	SC.. 09T3..	0,200		
212021900	212150200	SSSC R/L 2020 K12	20	20	125	22	25	SC.. 1204..	0,400		
212042700	212021800	SSSC R/L 2525 M12	25	25	150	22	32	SC.. 1204..	0,700		

 Stock Items | Items de stock







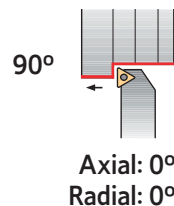

 Available under request | Disponível sob consulta | Disponible bajo consulta

SPARE PARTS | Complementos | Repuestos









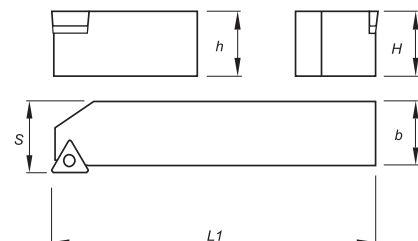





Cutter Reference	Shim	Shim Screw	Screw	Wrench
SSSC R/L 1212 F09				
SSSC R/L 1616 H09	-	-	P0401100	XT15-S35
SSSC R/L 2020 K12	CS120400	T06004000	P0401400	XT15-S40
SSSC R/L 2525 M12	CS120400	T06004000	P0401400	XT15-S40

(S) CENTER SCREW TOOLHOLDERS



Finishing	Finishing	Finishing	Finishing
Flat  (09-11-16)	FP  (09-11-16)	FM  (09-11-16)	FK  (09-11-16)
Medium	Medium	Medium	Medium to Finishing
MP  (09-11-16)	MM  (09-11-16)	MK  (09-11-16)	LN  (11-16)







Order Code		Reference	Dimensions (mm)				Insert	Kg	Stock	
R	L		H=h	b	L1	S			R	L
212151400	212151300	STAC R/L 0808 D09	8	8	60	8,5	TC.. 0902..	0,050		
212151600	212151500	STAC R/L 1010 E09	10	10	70	10,5	TC.. 0902..	0,070		
212151800	212151700	STAC R/L 1212 F11	12	12	80	12,5	TC.. 1102..	0,100		
212152000	212151900	STAC R/L 1616 H11	16	16	100	16,5	TC.. 1102..	0,200		
212152200	212152100	STAC R/L 1616 H16	16	16	100	16,5	TC.. 16T3..	0,200		
212260000	212260100	STAC R/L 2020 K16	20	20	125	20,5	TC.. 16T3..	0,400		
212152600	212152400	STAC R/L 2525 M16	25	25	150	25,5	TC.. 16T3..	0,700		

 Stock Items | Itens de stock







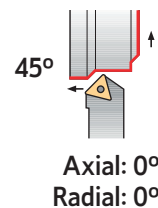

Available under request | Disponível sob consulta | Disponible bajo consulta

SPARE PARTS | Complementos | Repuestos









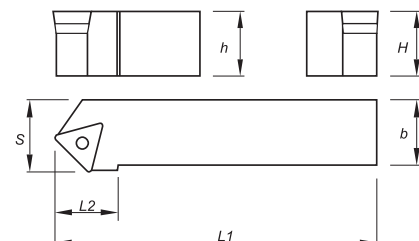







Cutter Reference	Shim	Shim Screw	Screw	Wrench
				
STAC R/L 0808 D09	-	-	P0220600	XT06
STAC R/L 1010 E09	-	-	P0220600	XT06
STAC R/L 1212 F11	-	-	P0250700	XT07
STAC R/L 1616 H11	-	-	P0250700	XT07
STAC R/L 1616 H16	CT160302	T05003500	P0351500	XT15-S35
STAC R/L 2020 K16	CT160302	T05003500	P0351500	XT15-S35
STAC R/L 2525 M16	CT160302	T05003500	P0351500	XT15-S35

(S) CENTER SCREW TOOLHOLDERS



Finishing	Finishing	Finishing	Finishing
Flat	FP	FM	FK
 (09-11-16)	 (09-11-16)	 (09-11-16)	 (09-11-16)
Medium	Medium	Medium	Medium to Finishing
MP	MM	MK	LN
 (09-11-16)	 (09-11-16)	 (09-11-16)	 (11-16)







Order Code		Reference	Dimensions (mm)					Insert	Kg	Stock	
R	L		H=h	b	L1	L2	S			R	L
212152800	212152700	STDC R/L 0808 D09	8	8	60	11	10	TC.. 0902..	0,050		
212153000	212152900	STDC R/L 1010 E09	10	10	70	11	11	TC.. 0902..	0,070		
212153200	212153100	STDC R/L 1212 F11	12	12	80	16	13	TC.. 1102..	0,100		
212153400	212153300	STDC R/L 1616 H11	16	16	100	16	17	TC.. 1102..	0,200		
212153600	212153500	STDC R/L 1212 F16	12	12	80	21	17	TC.. 16T3..	0,100		
212153800	212153700	STDC R/L 1616 H16	16	16	100	21	17	TC.. 16T3..	0,200		
212154000	212153900	STDC R/L 2020 K16	20	20	125	21	22	TC.. 16T3..	0,400		
212154200	212154100	STDC R/L 2525 M16	25	25	150	21	27	TC.. 16T3..	0,700		

 Stock Items | Itens de stock







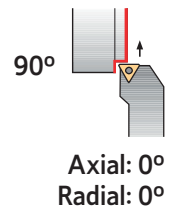

 Available under request | Disponível sob consulta | Disponible bajo consulta

SPARE PARTS | Complementos | Repuestos









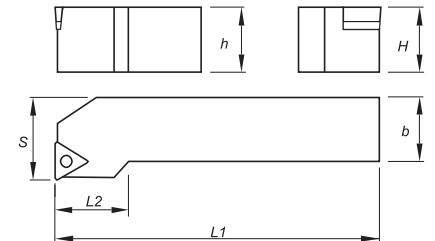







Cutter Reference	Shim	Shim Screw	Screw	Wrench
STDC R/L 0808 D09				
STDC R/L 1010 E09	-	-	P0220600	XT06
STDC R/L 1212 F11	-	-	P0250700	XT07
STDC R/L 1616 H11	-	-	P0250700	XT07
STDC R/L 1212 F16	-	-	P0401100	XT15-S35
STDC R/L 1616 H16	CT160302	T05003500	P0351500	XT15-S35
STDC R/L 2020 K16	CT160302	T05003500	P0351500	XT15-S35
STDC R/L 2525 M16	CT160302	T05003500	P0351500	XT15-S35

(S) CENTER SCREW TOOLHOLDERS



Finishing	Finishing	Finishing	Finishing
Flat  (09-11-16)	FP  (09-11-16)	FM  (09-11-16)	FK  (09-11-16)
Medium	Medium	Medium	Medium to Finishing
MP  (09-11-16)	MM  (09-11-16)	MK  (09-11-16)	LN  (11-16)







Order Code		Reference	Dimensions (mm)					Insert	Kg	Stock	
R	L		H=h	b	L1	L2	S			R	L
212154400	212154300	STFC R/L 0808 D09	8	8	60	16	10	TC.. 0902..	0,050		
212154600	212154500	STFC R/L 1010 E09	10	10	70	16	12	TC.. 0902..	0,070		
212154800	212154700	STFC R/L 1212 F11	12	12	80	18	16	TC.. 1102..	0,100		
212065800	212154900	STFC R/L 1616 H11	16	16	100	22	20	TC.. 1102..	0,200		
212155100	212155000	STFC R/L 1212 F16	12	12	80	18	16	TC.. 16T3..	0,100		
212056800	212155200	STFC R/L 1616 H16	16	16	100	22	20	TC.. 16T3..	0,200		
212056600	212155300	STFC R/L 2020 K16	20	20	125	22	25	TC.. 16T3..	0,400		
212155500	212155400	STFC R/L 2525 M16	25	25	150	22	32	TC.. 16T3..	0,700		

 Stock Items | Itens de stock







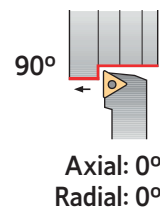

 Available under request | Disponível sob consulta | Disponible bajo consulta

SPARE PARTS | Complementos | Repuestos









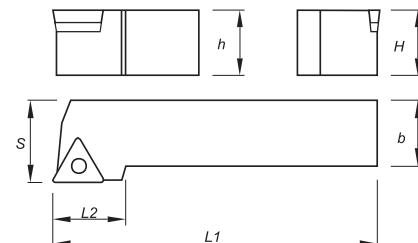







Cutter Reference	Shim 	Shim Screw 	Screw 	Wrench 
STFC R/L 0808 D09	-	-	P0220600	XT06
STFC R/L 1010 E09	-	-	P0220600	XT06
STFC R/L 1212 F11	-	-	P0250700	XT07
STFC R/L 1616 H11	-	-	P0250700	XT07
STFC R/L 1212 F16	-	-	P0401100	XT15-S35
STFC R/L 1616 H16	CT160302	T05003500	P0351500	XT15-S35
STFC R/L 2020 K16	CT160302	T05003500	P0351500	XT15-S35
STFC R/L 2525 M16	CT160302	T05003500	P0351500	XT15-S35

(S) CENTER SCREW TOOLHOLDERS



Finishing	Finishing	Finishing	Finishing
Flat	FP	FM	FK
 (09-11-16)	 (09-11-16)	 (09-11-16)	 (09-11-16)
Medium	Medium	Medium	Medium to Finishing
MP	MM	MK	LN
 (09-11-16)	 (09-11-16)	 (09-11-16)	 (11-16)







Order Code		Reference	Dimensions (mm)					Insert	Kg	Stock	
R	L		H=h	b	L1	L2	S			R	L
212155700	212155600	STGC R/L 0808 D09	8	8	60	16	10	TC.. 0902..	0,050		
212155900	212155800	STGC R/L 1010 E09	10	10	70	16	12	TC.. 0902..	0,070		
212156100	212156000	STGC R/L 1212 F11	12	12	80	18	16	TC.. 1102..	0,100		
212046100	212156200	STGC R/L 1616 H11	16	16	100	22	20	TC.. 1102..	0,200		
212156400	212156300	STGC R/L 1212 F16	12	12	80	18	16	TC.. 16T3..	0,100		
212156600	212156500	STGC R/L 1616 H16	16	16	100	22	20	TC.. 16T3..	0,200		
212156800	212156700	STGC R/L 2020 K16	20	20	125	22	25	TC.. 16T3..	0,400		
212157000	212156900	STGC R/L 2525 M16	25	25	150	22	32	TC.. 16T3..	0,700		

 Stock Items | Itens de stock

 Available under request | Disponível sob consulta | Disponible bajo consulta

SPARE PARTS | Complementos | Repuestos

Cutter Reference	Shim	Shim Screw	Screw	Wrench
STGC R/L 0808 D09				
STGC R/L 1010 E09	-	-	P0220600	XT06
STGC R/L 1212 F11	-	-	P0250700	XT07
STGC R/L 1616 H11	-	-	P0250700	XT07
STGC R/L 1212 F16	-	-	P0401100	XT15-S35
STGC R/L 1616 H16	CT160302	T05003500	P0351500	XT15-S35
STGC R/L 2020 K16	CT160302	T05003500	P0351500	XT15-S35
STGC R/L 2525 M16	CT160302	T05003500	P0351500	XT15-S35

C
TURNING
Insert selection
Overview
Negative inserts
Positive inserts
PCBN & PCD inserts
Heavy turning
External Toolholders
Internal Toolholders
Automatic Lathes
Spare Parts
Technical Data

(S) CENTER SCREW TOOLHOLDERS

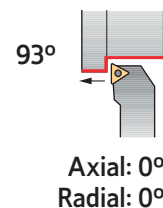

Finishing	Finishing	Finishing	Finishing	Finishing wiper
Flat (09-11-16)	FP (09-11-16)	FM (09-11-16)	FK (09-11-16)	FW (09-11-16)
Medium	Medium	Medium	Medium to Finishing wiper	Medium to Finishing
MP (09-11-16)	MM (09-11-16)	MK (09-11-16)	MW (11-16)	LN (11-16)

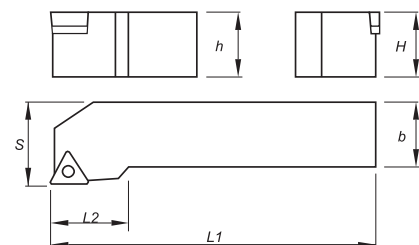

Order Code		Reference	Dimensions (mm)					Insert	Kg	Stock	
R	L		H=h	b	L1	L2	S			R	L
212157200	212157100	STJC R/L 0808 D09	8	8	60	16	10	TC.. 0902..	0,050		
212157400	212157300	STJC R/L 1010 E09	10	10	70	16	12	TC.. 0902..	0,070		
212157600	212157500	STJC R/L 1212 F11	12	12	80	18	16	TC.. 1102..	0,100		
212035400	212035500	STJC R/L 1616 H11	16	16	100	22	20	TC.. 1102..	0,200		
212157800	212157700	STJC R/L 1212 F16	12	12	80	18	16	TC.. 16T3..	0,100		
212035600	212035700	STJC R/L 1616 H16	16	16	100	22	20	TC.. 16T3..	0,200		
212036300	212031000	STJC R/L 2020 K16	20	20	125	22	25	TC.. 16T3..	0,400		
212038600	212038700	STJC R/L 2525 M16	25	25	150	22	32	TC.. 16T3..	0,700		









Stock Items | Itens de stock

Available under request | Disponível sob consulta | Disponible bajo consulta









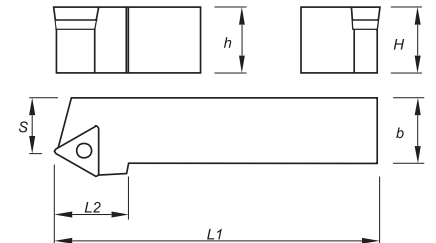
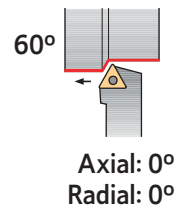







SPARE PARTS | Complementos | Repuestos

Cutter Reference	Shim	Shim Screw	Screw	Wrench
STJC R/L 0808 D09	-	-	P0220600	XT06
STJC R/L 1010 E09	-	-	P0220600	XT06
STJC R/L 1212 F11	-	-	P0250700	XT07
STJC R/L 1616 H11	-	-	P0250700	XT07
STJC R/L 1212 F16	-	-	P0401100	XT15-S35
STJC R/L 1616 H16	CT160302	T05003500	P0351500	XT15-S35
STJC R/L 2020 K16	CT160302	T05003500	P0351500	XT15-S35
STJC R/L 2525 M16	CT160302	T05003500	P0351500	XT15-S35

(S) CENTER SCREW TOOLHOLDERS

Finishing	Finishing	Finishing	Finishing
Flat	FP	FM	FK
 (09-11-16)	 (09-11-16)	 (09-11-16)	 (09-11-16)
Medium	Medium	Medium	Medium to Finishing
MP	MM	MK	LN
 (09-11-16)	 (09-11-16)	 (09-11-16)	 (11-16)







Order Code		Reference	Dimensions (mm)					Insert	Kg	Stock	
R	L		H=h	b	L1	L2	S			R	L
212158000	212157900	STTC R/L 0808 D09	8	8	60	16	7	TC.. 0902..	0,050		
212158200	212158100	STTC R/L 1010 E09	10	10	70	16	9	TC.. 0902..	0,070		
212158400	212158300	STTC R/L 1212 F11	12	12	80	18	11	TC.. 1102..	0,100		
212047500	212158500	STTC R/L 1616 H11	16	16	100	18	13	TC.. 1102..	0,200		
212158700	212158600	STTC R/L 1212 F16	12	12	80	22	11	TC.. 16T3..	0,100		
212158900	212158800	STTC R/L 1616 H16	16	16	100	22	13	TC.. 16T3..	0,200		
212159100	212159000	STTC R/L 2020 K16	20	20	125	22	17	TC.. 16T3..	0,400		
212159300	212159200	STTC R/L 2525 M16	25	25	150	22	22	TC.. 16T3..	0,700		

 Stock Items | Itens de stock

 Available under request | Disponível sob consulta | Disponible bajo consulta







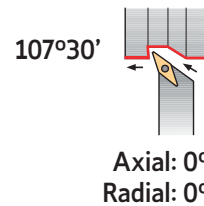

SPARE PARTS || Complementos | Repuestos

Cutter Reference	Shim	Shim Screw	Screw	Wrench
STTC R/L 0808 D09				
STTC R/L 1010 E09	-	-	P0220600	XT06
STTC R/L 1212 F11	-	-	P0250700	XT07
STTC R/L 1616 H11	-	-	P0250700	XT07
STTC R/L 1212 F16	-	-	P0401100	XT15-S35
STTC R/L 1616 H16	CT160302	T05003500	P0351500	XT15-S35
STTC R/L 2020 K16	CT160302	T05003500	P0351500	XT15-S35
STTC R/L 2525 M16	CT160302	T05003500	P0351500	XT15-S35









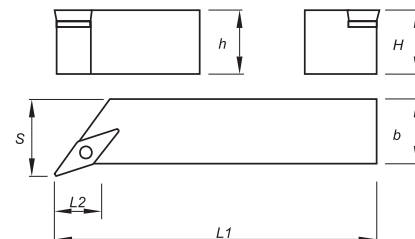

C
TURNING
Insert selection
Overview
Negative inserts
Positive inserts
PCBN & PCD inserts
Heavy turning
External Toolholders
Internal Toolholders
Automatic Lathes
Spare Parts
Technical Data

(S) CENTER SCREW TOOLHOLDERS



Finishing	Finishing	Finishing	Finishing
Flat	FP	FM	FK
 (16)	 (16)	 (16)	 (16)
Medium	Medium	Medium	Medium to Finishing
MP	MM	MK	LN
 (16)	 (16)	 (16)	 (16-22)







Order Code		Reference	Dimensions (mm)					Insert	Kg	Stock	
R	L		H=h	b	L1	L2	S			R	L
212161000	212160900	SVHC R/L 2020 K16	20	20	125	15,4	25	VC.. 1604..	0,400		
212161200	212161100	SVHC R/L 2525 M16	25	25	150	21,0	32	VC.. 1604..	0,700		
212161400	212161300	SVHC R/L 3225 P16	32	25	170	21,0	32	VC.. 1604..	0,900		
212161500	212161600	SVHC R/L 2525 M22	25	25	150	19,6	32	VC.. 2205..	0,700		
212161700	212161800	SVHC R/L 3225 P22	32	25	170	19,6	32	VC.. 2205..	0,900		

 Stock Items | Itens de stock





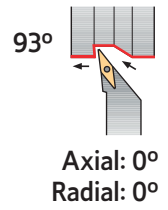

 Available under request | Disponível sob consulta | Disponible bajo consulta

SPARE PARTS || Complementos | Repuestos

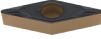



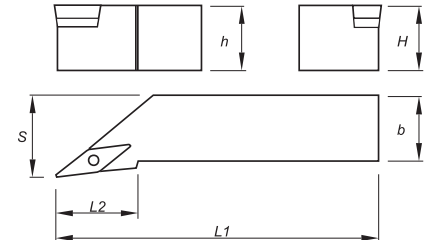

Cutter Reference	Shim	Shim Screw	Screw	Wrench
SVHC R/L 2020 K16	 CV160300	 T05003500	 P0351500	 XT15-S35
SVHC R/L 2525 M16	CV160300	T05003500	P0351500	XT15-S35
SVHC R/L 3225 P16	CV160300	T05003500	P0351500	XT15-S35
SVHC R/L 2525 M22	CV220400	T06004000	P0401400	XT20-S40
SVHC R/L 3225 P22	CV220400	T06004000	P0401400	XT20-S40

(S) CENTER SCREW TOOLHOLDERS



Finishing	Finishing	Finishing	Finishing
Flat	FP	FM	FK
 (16)	 (16)	 (16)	 (16)
Medium	Medium	Medium	
MP	MM	MK	
 (16)	 (16)	 (16)	



Order Code		Reference	Dimensions (mm)					Insert	Kg	Stock	
R	L		H=h	b	L1	L2	S			R	L
212055300	212363000	SVJB R/L 2020 K16	20	20	125	37	25	VB.. 1604..	0,400		
212022200	212022000	SVJB R/L 2525 M16	25	25	150	37	32	VB.. 1604..	0,700		
212022300	212022100	SVJB R/L 3225 P16	32	25	170	37	32	VB.. 1604..	0,900		

 Stock Items | Itens de stock

 Available under request | Disponível sob consulta | Disponible bajo consulta







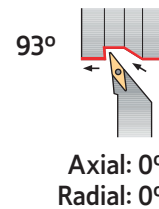

SPARE PARTS || Complementos | Repuestos

Cutter Reference	Shim	Shim Screw	Screw	Wrench
SVJB R/L 2020 K16	 CV160300	 T05003500	 P0351500	 XT15-S35
SVJB R/L 2525 M16	 CV160300	 T05003500	 P0351500	 XT15-S35
SVJB R/L 3225 P16	 CV160300	 T05003500	 P0351500	 XT15-S35









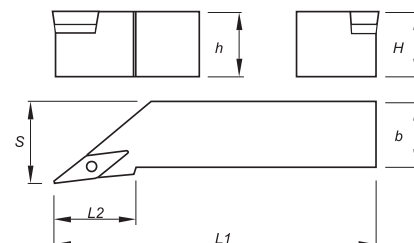





C
TURNING
Insert selection
Overview
Negative inserts
Positive inserts
PCBN & PCD inserts
Heavy turning
External Toolholders
Internal Toolholders
Automatic Lathes
Spare Parts
Technical Data

(S) CENTER SCREW TOOLHOLDERS



Finishing	Finishing	Finishing	Finishing
Flat	FP	FM	FK
 (11-16)	 (11-16)	 (11-16)	 (11-16)
Medium	Medium	Medium	Medium to Finishing
MP	MM	MK	LN
 (11-16)	 (11-16)	 (11-16)	 (11-16)





Order Code		Reference	Dimensions (mm)					Insert	Kg	Stock	
R	L		H=h	b	L1	L2	S			R	L
212161900	212162000	SVJC R/L 1212 F11	12	12	80	25	16	VC.. 1103..	0,100		
212056400	212162100	SVJC R/L 1616 H11	16	16	100	25	20	VC.. 1103..	0,200		
212162200	212162300	SVJC R/L 2020 K11	20	20	125	25	25	VC.. 1103..	0,400		
212392400	212420900	SVJC R/L 2525 M11	25	25	150	28	32	VC.. 1103..	0,700		
212031100	212031200	SVJC R/L 2020 K16	20	20	125	37	25	VC.. 1604..	0,400		
212031300	212031400	SVJC R/L 2525 M16	25	25	150	37	32	VC.. 1604..	0,700		
212162500	212162400	SVJC R/L 3225 P16	32	25	170	37	32	VC.. 1604..	0,900		

 Stock Items | Itens de stock

 Available under request | Disponível sob consulta | Disponible bajo consulta

SPARE PARTS || Complementos | Repuestos

Cutter Reference	Shim	Shim Screw	Screw	Wrench
SVJC R/L 1212 F11		-	-	
SVJC R/L 1616 H11	-	-	P0250700	XT07
SVJC R/L 2020 K11	-	-	P0250700	XT07
SVJC R/L 2525 M11	-	-	P0250700	XT07
SVJC R/L 2020 K16	CV160300	T05003500	P0351500	XT15-S35
SVJC R/L 2525 M16	CV160300	T05003500	P0351500	XT15-S35
SVJC R/L 3225 P16	CV160300	T05003500	P0351500	XT15-S35

(S) CENTER SCREW TOOLHOLDERS

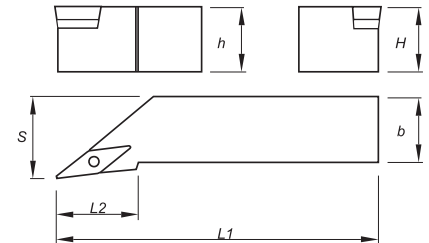
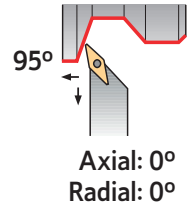

Order Code		Reference	Dimensions (mm)					Insert	Kg	Stock	
R	L		H=h	b	L1	L2	S			R	L
212041900	212162600	SVLC R/L 1212 G13	12	12	90	25	16	VCGT 1303..	0,100		
212162800	212162700	SVLC R/L 1616 H13	16	16	100	25	20	VCGT 1303..	0,200		
212163000	212162900	SVLC R/L 2020 K13	20	20	125	28	25	VCGT 1303..	0,400		
212163200	212163100	SVLC R/L 2525 M13	25	25	150	30	32	VCGT 1303..	0,700		

Stock Items | Itens de stock

Available under request | Disponível sob consulta | Disponible bajo consulta





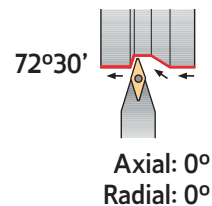

SPARE PARTS | Complementos | Repuestos

Cutter Reference	Screw	Wrench
SVLC R/L 1212 G13	P0300900	XT08
SVLC R/L 1616 H13	P0300900	XT08
SVLC R/L 2020 K13	P0300900	XT08
SVLC R/L 2525 M13	P0300900	XT08

C
TURNING
Insert selection
Overview
Negative inserts
Positive inserts
PCBN & PCD inserts
Heavy turning
External Toolholders
Internal Toolholders
Automatic Lathes
Spare Parts
Technical Data

(S) CENTER SCREW TOOLHOLDERS



Finishing	Finishing	Finishing	Finishing
Flat	FP	FM	FK
			
(16)	(16)	(16)	(16)
Medium	Medium	Medium	
MP	MM	MK	
			
(16)	(16)	(16)	

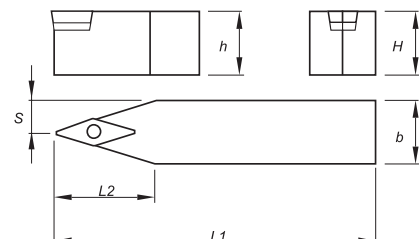





Order Code	Reference	Dimensions (mm)					Insert	Kg	Stock
		H=h	b	L1	L2	S			
212260200	SVVB N 2020 K16	20	20	125	37	10,6	VB.. 1604..	0,400	☉
212169500	SVVB N 2525 M16	25	25	150	37	13,1	VB.. 1604..	0,700	☉
212260300	SVVB N 3225 P16	32	25	170	37	13,1	VB.. 1604..	0,900	☉

☉ Stock Items | Itens de stock





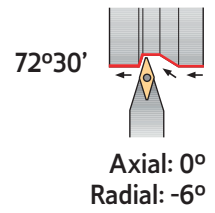

○ Available under request | Disponível sob consulta | Disponible bajo consulta

SPARE PARTS || Complementos | Repuestos

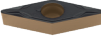



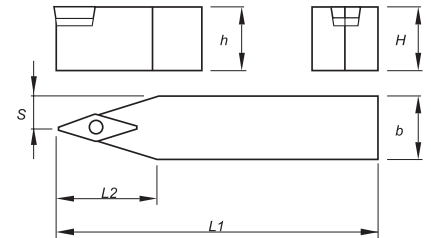

Cutter Reference	Shim	Shim Screw	Screw	Wrench
SVVB N 2020 K16				
SVVB N 2525 M16	CV160300	T05003500	P0351500	XT15-S35
SVVB N 3225 P16	CV160300	T05003500	P0351500	XT15-S35

(S) CENTER SCREW TOOLHOLDERS



Finishing	Finishing	Finishing	Finishing
Flat	FP	FM	FK
 (11-16)	 (11-16)	 (11-16)	 (11-16)
Medium	Medium	Medium	Medium to Finishing
MP	MM	MK	LN
 (11-16)	 (11-16)	 (11-16)	 (11-16)







Order Code	Reference	Dimensions (mm)					Insert	Kg	Stock
		H=h	b	L1	L2	S			
212163300	SVVC N 1212 F11	12	12	80	25	6,6	VC.. 1103..	0,100	
212163400	SVVC N 1616 H11	16	16	100	25	8,6	VC.. 1103..	0,200	
212163500	SVVC N 2020 K11	20	20	125	25	10,6	VC.. 1103..	0,400	
212042500	SVVC N 2020 K16	20	20	125	37	10,6	VC.. 1604..	0,400	
212163600	SVVC N 2525 M16	25	25	150	37	13,1	VC.. 1604..	0,700	
212022400	SVVC N 3225 P16	32	25	170	37	13,1	VC.. 1604..	0,900	

 Stock Items | Itens de stock

 Available under request | Disponível sob consulta | Disponible bajo consulta

SPARE PARTS || Complementos | Repuestos

Cutter Reference	Shim	Shim Screw	Screw	Wrench
				
SVVC N 1212 F11	-	-	P0250700	XT07
SVVC N 1616 H11	-	-	P0250700	XT07
SVVC N 2020 K11	-	-	P0250700	XT07
SVVC N 2020 K16	CV160300	T05003500	P0351500	XT15-S35
SVVC N 2525 M16	CV160300	T05003500	P0351500	XT15-S35
SVVC N 3225 P16	CV160300	T05003500	P0351500	XT15-S35

(S) CENTER SCREW TOOLHOLDERS

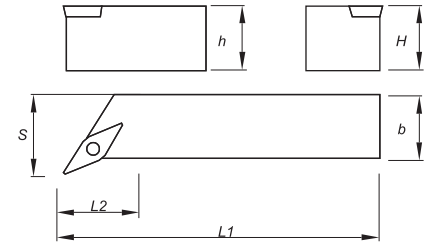
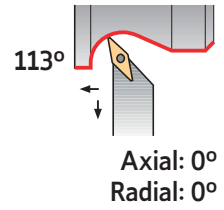

Order Code		Reference	Dimensions (mm)					Insert	Kg	Stock	
R	L		H=h	b	L1	L2	S			R	L
212163800	212163700	SVXC R/L 1212 G13	12	12	90	11,5	16	VCGT 1303..	0,100		
212164000	212163900	SVXC R/L 1616 H13	16	16	100	13,8	20	VCGT 1303..	0,200		
212164200	212164100	SVXC R/L 2020 K13	20	20	125	10,4	25	VCGT 1303..	0,400		
212164400	212164300	SVXC R/L 2525 M13	25	25	150	20,2	32	VCGT 1303..	0,700		

Stock Items | Itens de stock





Available under request | Disponível sob consulta | Disponible bajo consulta

SPARE PARTS | Complementos | Repuestos

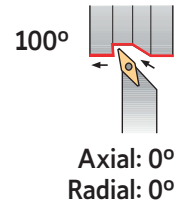

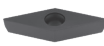
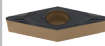
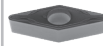
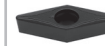

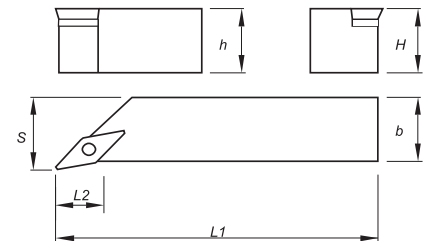

Cutter Reference	Screw	Wrench
SVXC R/L 1212 G13	P0300900	XT08
SVXC R/L 1616 H13	P0300900	XT08
SVXC R/L 2020 K13	P0300900	XT08
SVXC R/L 2525 M13	P0300900	XT08

(S) CENTER SCREW TOOLHOLDERS



Finishing	Finishing	Finishing	Finishing
Flat	FP	FM	FK
 (16)	 (16)	 (16)	 (16)
Medium	Medium	Medium	Medium to Finishing
MP	MM	MK	LN
 (16)	 (16)	 (16)	 (16)



Order Code		Reference	Dimensions (mm)					Insert	Kg	Stock	
R	L		H=h	b	L1	L2	S			R	L
212164600	212164500	SVZC R/L 2020 K16	20	20	125	25,7	25	VC..1604..	0,400		
212164700	212044500	SVZC R/L 2525 M16	25	25	150	28,5	32	VC..1604..	0,700		
212164900	212164800	SVZC R/L 3225 P16	32	25	170	28,5	32	VC..1604..	0,900		

 Stock Items | Itens de stock

 Available under request | Disponível sob consulta | Disponible bajo consulta

SPARE PARTS | Complementos | Repuestos



Cutter Reference	Shim	Shim Screw	Screw	Wrench
SVZC R/L 2020 K16	 CV160300	 T05003500	 P0351500	 XT15-S35
SVZC R/L 2525 M16	 CV160300	 T05003500	 P0351500	 XT15-S35
SVZC R/L 3225 P16	 CV160300	 T05003500	 P0351500	 XT15-S35

CODE KEY FOR INTERNAL TURNING TOOLHOLDERS

Sistema De Codificação Para Suportes De Torneamento Interno (ISO) | Codificación De Herramientas De Torneado Interior (ISO)

S	25	T	S	D	U	C	R	11	-	BT
1	2	3	4	5	6	7	8	9	-	10

1 - Bar Type

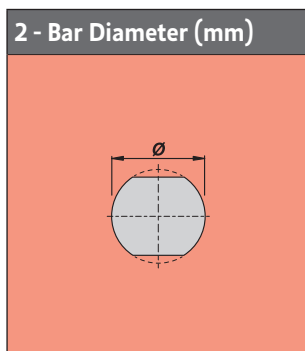

A	Steel shank with internal coolant		
E	Anti-vibration shank (heavy metal) with internal coolant		
S	Steel shank		

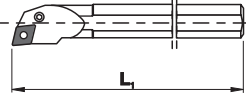

3 - Bar Length (mm)

	H	100	T	300
	J	110	U	350
	K	125	V	400
	L	140	W	450
	M	150	Y	500
	Q	180	X	Special
	R	200		
	S	250		

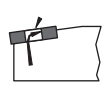
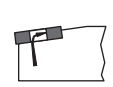





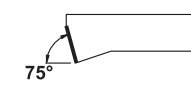
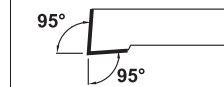
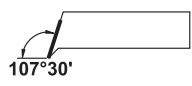
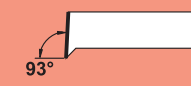
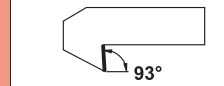

4 - Inserts Clamping System

			
C	M	P	S





6 - Bar Leading Angle

		
F	K	L
		
Q	U	U-BT



5 - Insert Shape

			
C	D	E	K
			
S	T	V	W





7 - Inserts Clearance Angle

			
B	C	N	P

8 - Bar Hand

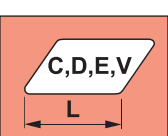
		
L	R	N

9 - Length of Inserts Cutting Edge (mm)

				
C,D,E,V	K	S	T	W

10 - Manufacturer's Option

--



- C - 612 | Top Clamp Toolholders (C)
- C - 617 | Dimple Lock Toolholders (D)
- C - 620 | Wedge Clamp (M) & Double Lock (M-K) Toolholders
- C - 630 | Lever Lock Toolholders (P)
- C - 644 | Center Screw Toolholders (S)
- C - 668 | Anti-vibration tools
- C - 679 | Internal Toolholders set

INTERNAL TURNING

CLAMPING SYSTEMS FOR INTERNAL TOOLHOLDERS

Sistemas De Fixação Para Ferramentas De Torneamento Interno | Sistemas De Fijación Para Herramientas De Torneado Interior

(C) TOP CLAMP SYSTEM

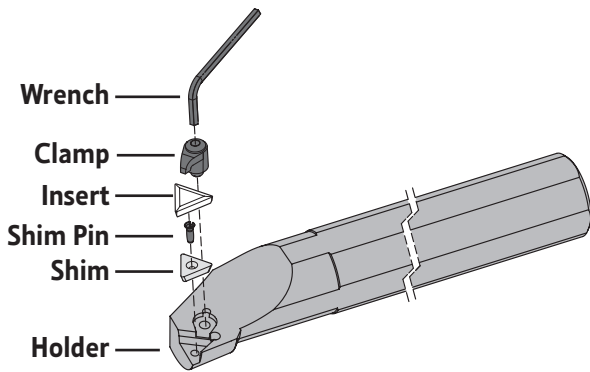

(D) DIMPLE LOCK SYSTEM

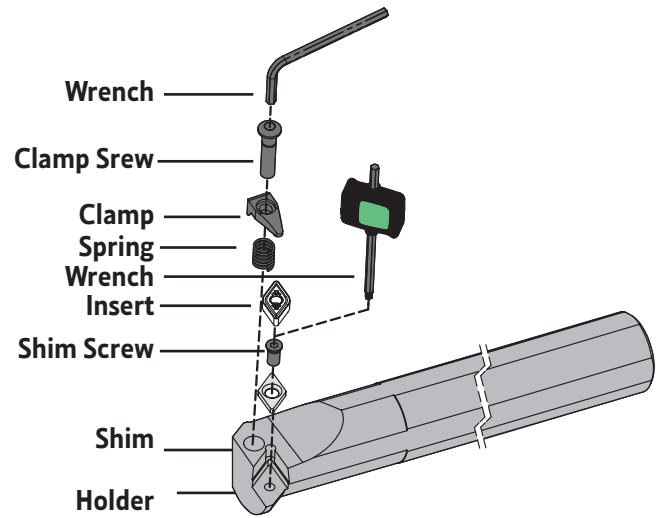

(M) WEDGE CLAMP SYSTEM

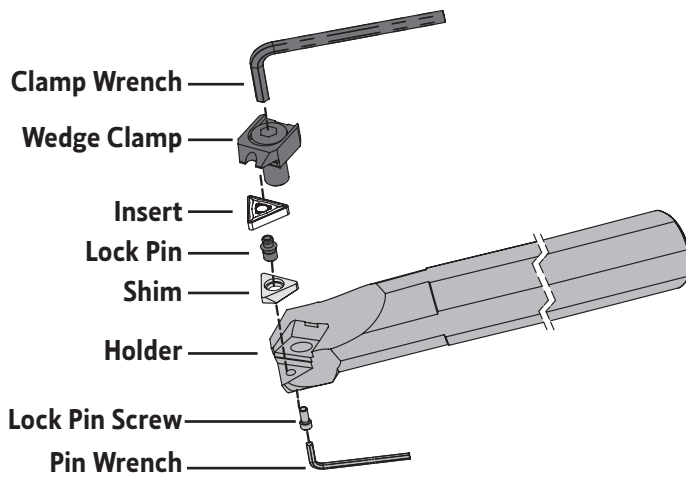

(P) LEVER LOCK SYSTEM

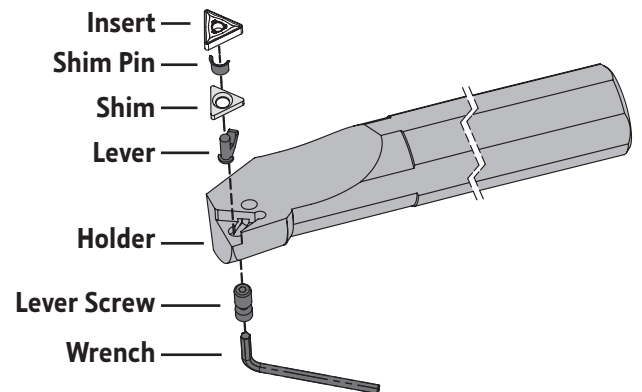

(M-K) DOUBLE LOCK SYSTEM

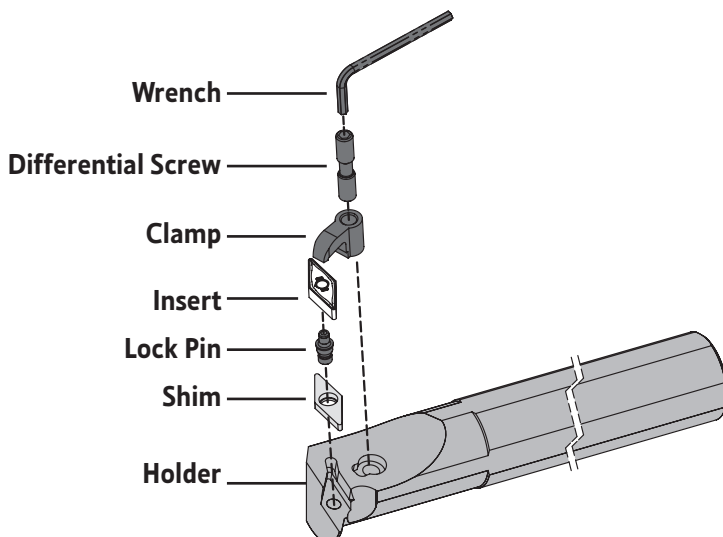

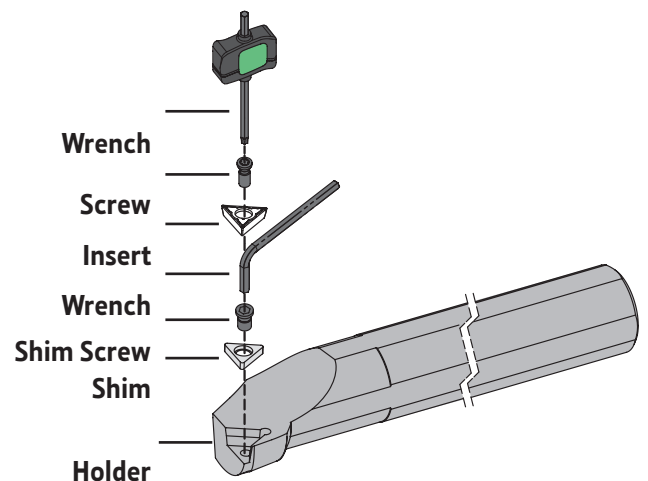

(S) CENTER SCREW SYSTEM

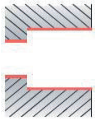

TURNING
Insert selection
Overview
Negative inserts
Positive inserts
PCBN & PCD inserts
Heavy turning
External Toolholders
Internal Toolholders
Automatic Lathes
Spare Parts
Technical Data

SUITABLE CLAMPING SYSTEM DEFINITION
 Definição do sistema de fixação | Definición del sistema de Fijación

Insert Shape & page		Operation	Longitudinal turning	Profiling	Facing
					
Negative inserts	(C) TOP CLAMP SYSTEM	●	●	●	
	(D) DIMPLE LOCK SYSTEM	● ●	●		
	(M) WEDGE CLAMP SYSTEM	●	●	●	
	(P) LEVER LOCK SYSTEM	● ●	●	●	●
Positive inserts	(C) TOP CLAMP SYSTEM	●			
	(S) CENTER SCREW SYSTEM	● ●	● ●	● ●	● ●
			● ● Recommended Insert Shape	● Alternative Insert Shape	

- TURNING
- Insert selection
- Overview
- Negative inserts
- Positive inserts
- PCBN & PCD inserts
- Heavy turning
- External Toolholders
- Internal Toolholders
- Automatic Lathes
- Spare Parts
- Technical Data

(C) TOP CLAMP SYSTEM

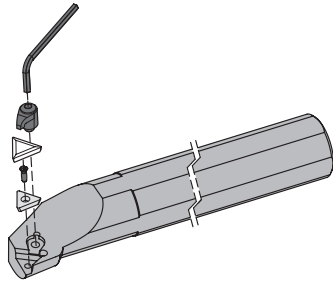

CKUN 93°	CSKP 75°	CTFP 90°	CTUP 93°
PAGE C - 613 KNUX 1604..	PAGE C - 614 SP. 0903.. SP. 1203.. SP. 1904..	PAGE C - 615 TP. 0903.. ... TP. 2204..	PAGE C - 616 TP. 0903.. ... TP. 2204..

(C) TOP CLAMP TOOLHOLDERS

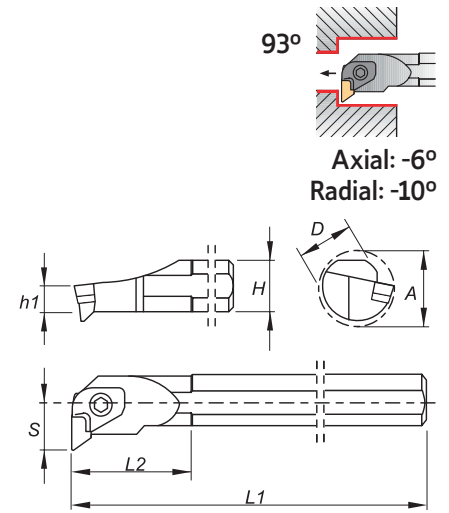
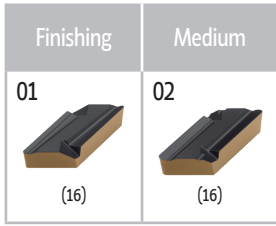

Order Code		Reference	Dimensions (mm)							Insert	Kg	Stock	
R	L		D	H	h1	L1	L2	S	A			R	L
212038300	212028200	S25T CKUN R/L 16	25	23	11,5	300	50	20,5	37	KNUX 1604..	0,700	⊗	⊗
212028300	212028400	S32U CKUN R/L 16	32	30	15,0	350	54	22,0	39	KNUX 1604..	2,050	○	○
212329300	212329400	S40V CKUN R/L 16	40	37	18,5	400	60	27,0	48	KNUX 1604..	3,750	○	○
212329500	212329600	S50W CKUN R/L 16	50	47	23,5	450	65	35,0	61	KNUX 1604..	6,500	○	○

⊗ Stock Items | Itens de stock



○ Available under request | Disponível sob consulta | Disponible bajo consulta

SPARE PARTS || Complementos | Repuestos

Cutter Reference	Order separately						
	Shim	Shim Pin	Shim Pin Punch	Spring	Clamp	Screw	Wrench
S25T CKUN R 16	-	-	BF04806	M09513	GAW1401	DW142600	SS40
S32U CKUN R 16	CK160501	BE03000	BF04808	M09513	GAW1401	DW142600	SS40
S40V CKUN R 16	CK160501	BE03000	BF04815	M09513	GAW1401	DW142600	SS40
S50W CKUN R 16	CK160501	BE03000	BF04815	M09513	GAW1401	DW142600	SS40
S25T CKUN L 16	-	-	BF04806	M09513	GAW1400	DW142600	SS40
S32U CKUN L 16	CK160500	BE03000	BF04808	M09513	GAW1400	DW142600	SS40
S40V CKUN L 16	CK160500	BE03000	BF04815	M09513	GAW1400	DW142600	SS40
S50W CKUN L 16	CK160500	BE03000	BF04815	M09513	GAW1400	DW142600	SS40

C
TURNING
Insert selection
Overview
Negative inserts
Positive inserts
PCBN & PCD inserts
Heavy turning
External Toolholders
Internal Toolholders
Automatic Lathes
Spare Parts
Technical Data





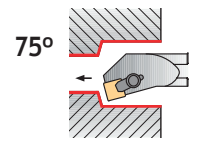



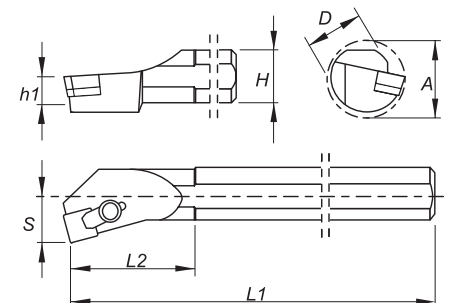





(C) TOP CLAMP TOOLHOLDERS

Medium to Finishing	Finishing to Fine Finishing	Medium
Flat  (09-12-19)	12  (09-12)	13  (09-12)



Axial: 6,5°
Radial: -1,25°









Order Code		Reference	Dimensions (mm)							Insert	Kg	Stock	
R	L		D	H	h1	L1	L2	S	A			R	L
212027500	212027600	S16R CSKP R/L 09	16	15	7,5	200	30	11	20	SP.. 0903..	0,300		
212027700	212027800	S20S CSKP R/L 09	20	18	9,0	250	35	13	24	SP.. 0903..	0,550		
212329700	212027900	S25T CSKP R/L 12	25	23	11,5	300	40	17	31	SP.. 1203..	1,050		
212028000	212028100	S32U CSKP R/L 12	32	30	15,0	350	50	22	39	SP.. 1203..	2,050		
212329800	212329900	S40V CSKP R/L 12	40	37	18,5	400	60	27	48	SP.. 1203..	3,650		
212330000	212330100	S50W CSKP R/L 12	50	47	23,5	450	65	35	61	SP.. 1203..	6,450		
212330200	212330300	S50W CSKP R/L 19	50	47	23,5	450	65	35	61	SP.. 1904..	6,400		

 Stock Items | Itens de stock



 Available under request | Disponível sob consulta | Disponible bajo consulta

SPARE PARTS || Complementos | Repuestos

Complementary Accessories - Flat Inserts

Cutter Reference	Shim	Shim Pin	Clamp	Wrench	Clamp	Chip Breaker 1	Chip Breaker 2
S16R CSKP R/L 09							
S16R CSKP R/L 09	-	-	GS05000	SS25	-	QCS0900	-
S20S CSKP R/L 09	-	-	GS05000	SS25	-	QCS1200	QCS1201
S25T CSKP R/L 12	-	-	GS06001	SS30	GS06003	QCS1200	QCS1201
S32U CSKP R/L 12	CS120300	BE02100	GS06001	SS30	GS06003	QCS1200	QCS1201
S40V CSKP R/L 12	CS120300	BE02100	GS06001	SS30	GS06003	QCS1200	QCS1201
S50W CSKP R/L 12	CS120300	BE02100	GS06001	SS30	GS06003	QCS1200	QCS1201
S50W CSKP R/L 19	CS190300	BE03000	GS08000	SS40	GS08001	QCS1900	QCS1901

(C) TOP CLAMP TOOLHOLDERS

Medium to Finishing	Finishing to Fine Finishing	Medium
Flat  (11-16-22)	12  (09-11-16)	13  (09-11-16-22)

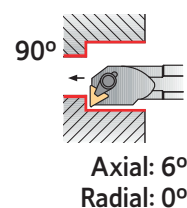
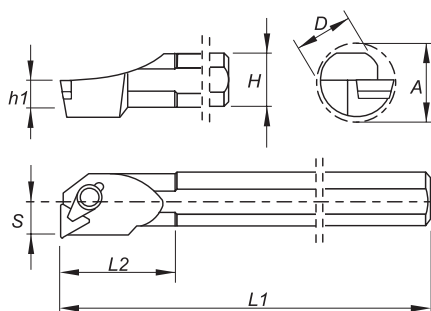

Order Code		Reference	Dimensions (mm)							Insert	Kg	Stock	
R	L		D	H	h1	L1	L2	S	A			R	L
212330400	212330500	S10M CTFP R/L 09	10	9	4,5	150	25	7	13	TP.. 0902..	0,060		
212330600	212330700	S12M CTFP R/L 09	12	11	5,5	150	25	9	16	TP.. 0902..	0,150		
212170200	212330800	S12M CTFP R/L 11	12	11	5,5	150	25	9	16	TP.. 1103..	0,150		
212026800	212026900	S16R CTFP R/L 11	16	15	7,5	200	30	11	20	TP.. 1103..	0,300		
212027000	212027100	S20S CTFP R/L 11	20	18	9,0	250	35	13	24	TP.. 1103..	0,550		
212330900	212331000	S16R CTFP R/L 16	16	15	7,5	200	30	11	20	TP.. 1603..	0,300		
212331100	212331200	S20S CTFP R/L 16	20	18	9,0	250	35	13	24	TP.. 1603..	0,550		
212036700	212027200	S25T CTFP R/L 16	25	23	11,5	300	40	17	31	TP.. 1603..	0,700		
212027300	212027400	S32U CTFP R/L 16	32	30	15,0	350	50	22	39	TP.. 1603..	2,050		
212331300	212331700	S40V CTFP R/L 16	40	37	18,5	400	60	27	48	TP.. 1603..	3,750		
212331800	212331900	S50W CTFP R/L 16	50	47	23,5	450	65	35	61	TP.. 1603..	6,500		
212021300	212332000	S40V CTFP R/L 22	40	37	18,5	400	60	27	48	TP.. 2204..	3,750		
212332100	212332200	S50W CTFP R/L 22	50	47	23,5	450	65	35	61	TP.. 2204..	6,500		

Stock Items | Itens de stock



Available under request | Disponível sob consulta | Disponible bajo consulta

SPARE PARTS | Complementos | Repuestos









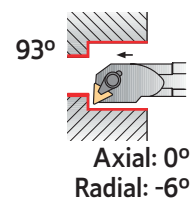
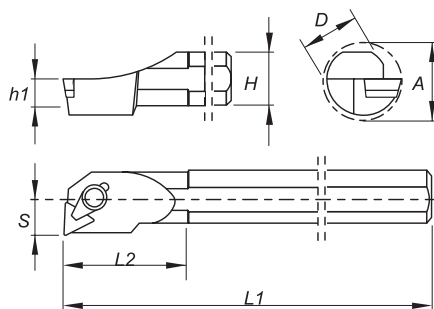

















Complementary Accessories - Flat Inserts

Cutter Reference	Shim	Shim Pin	Clamp	Wrench	Clamp	Chip Breaker 1	Chip Breaker 2
S10M CTFP R/L 09	-	-	GS03000	SS15	-	-	-
S12M CTFP R/L 09	-	-	GS03000	SS15	-	-	-
S12M CTFP R/L 11	-	-	GS04000	SS25	-	-	-
S16R CTFP R/L 11	-	-	GS05000	SS25	GS05003	QCT1100	QCT1101
S20S CTFP R/L 11	-	-	GS05000	SS25	GS05003	QCT1100	QCT1101
S16R CTFP R/L 16	-	-	GS06002	SS30	GS06003	QCT1600	QCT1601
S20S CTFP R/L 16	-	-	GS06002	SS30	GS06003	QCT1600	QCT1601
S25T CTFP R/L 16	-	-	GS06001	SS30	GS06003	QCT1600	QCT1601
S32U CTFP R/L 16	CT160301	BE02100	GS06000	SS30	GS06003	QCT1600	QCT1601
S40V CTFP R/L 16	CT160301	BE02100	GS06000	SS30	GS05005	QCT1600	QCT1601
S50W CTFP R/L 16	CT160301	BE02100	GS06000	SS30	GS05005	QCT1600	QCT1601
S40V CTFP R/L 22	CT220301	BE03000	GS08000	SS40	GS08001	QCT2200	QCT2201
S50W CTFP R/L 22	CT220301	BE03000	GS08000	SS40	GS08001	QCT2200	QCT2201

(C) TOP CLAMP TOOLHOLDERS

Medium to Finish	Finishing to Fine Finishing	Medium
Flat  (11-16-22)	12  (09-11-16)	13  (09-11-16-22)



Order Code		Reference	Dimensions (mm)							Insert	Kg	Stock	
R	L		D	H	h1	L1	L2	S	A			R	L
212245500	212332300	S10M CTUP R/L 09	10	9	4,5	150	25	7	13	TP.. 0902..	0,060		
212332400	212332500	S12M CTUP R/L 09	12	11	5,5	150	25	9	16	TP.. 0902..	0,150		
212332600	212332700	S12M CTUP R/L 11	12	11	5,5	150	25	9	16	TP.. 1103..	0,150		
212332800	212332900	S16R CTUP R/L 11	16	15	7,5	200	30	11	20	TP.. 1103..	0,300		
212333000	212333100	S20S CTUP R/L 11	20	18	9,0	250	35	13	24	TP.. 1103..	0,550		
212333200	212333300	S16R CTUP R/L 16	16	15	7,5	200	30	11	20	TP.. 1603..	0,300		
212333400	212333500	S20S CTUP R/L 16	20	18	9,0	250	35	13	24	TP.. 1603..	0,550		
212245600	212333600	S25T CTUP R/L 16	25	23	11,5	300	40	17	31	TP.. 1603..	0,700		
212333700	212333800	S32U CTUP R/L 16	32	30	15,0	350	50	22	39	TP.. 1603..	2,050		
212245700	212333900	S40V CTUP R/L 16	40	37	18,5	400	60	27	48	TP.. 1603..	3,750		
212334000	212334100	S50W CTUP R/L 16	50	47	23,5	450	65	35	61	TP.. 1603..	6,500		
212334200	212334300	S40V CTUP R/L 22	40	37	18,5	400	60	27	48	TP.. 2204..	3,750		
212334400	212334500	S50W CTUP R/L 22	50	47	23,5	450	65	35	61	TP.. 2204..	6,500		

 Stock Items | Itens de stock

 Available under request | Disponible sob consulta | Disponible bajo consulta







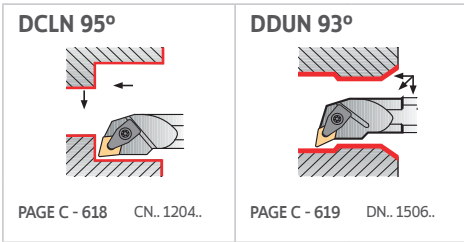
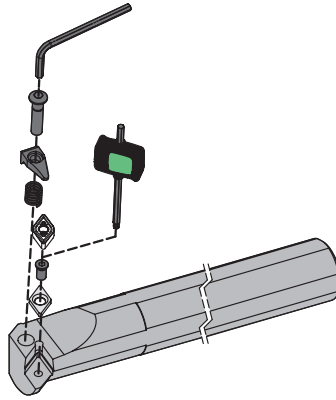



SPARE PARTS | Complementos | Repuestos

Cutter Reference	Complementary Accessories - Flat Inserts						
	Shim	Shim Pin	Clamp	Wrench	Clamp	Chip Breaker 1	Chip Breaker 2
S10M CTUP R/L 09	-	-	GS03000	SS15	-	-	-
S12M CTUP R/L 09	-	-	GS03000	SS15	-	-	-
S12M CTUP R/L 11	-	-	GS04000	SS25	-	-	-
S16R CTUP R/L 11	-	-	GS05000	SS25	GS05003	QCT1100	QCT1101
S20S CTUP R/L 11	-	-	GS05000	SS25	GS05003	QCT1100	QCT1101
S16R CTUP R/L 16	-	-	GS06002	SS30	GS06003	QCT1600	QCT1601
S20S CTUP R/L 16	-	-	GS06002	SS30	GS06003	QCT1600	QCT1601
S25T CTUP R/L 16	-	-	GS06001	SS30	GS06003	QCT1600	QCT1601
S32U CTUP R/L 16	CT160301	BE02100	GS06000	SS30	GS06003	QCT1600	QCT1601
S40V CTUP R/L 16	CT160301	BE02100	GS06000	SS30	GS05005	QCT1600	QCT1601
S50W CTUP R/L 16	CT160301	BE02100	GS06000	SS30	GS05005	QCT1600	QCT1601
S40V CTUP R/L 22	CT220301	BE03000	GS08000	SS40	GS08001	QCT2200	QCT2201
S50W CTUP R/L 22	CT220301	BE03000	GS08000	SS40	GS08001	QCT2200	QCT2201







(D) DIMPLE LOCK SYSTEM

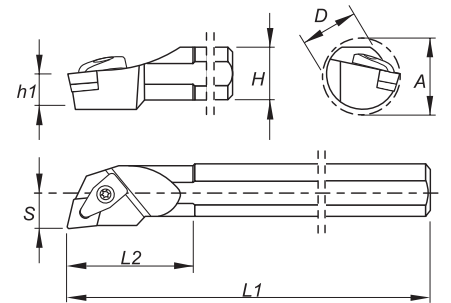
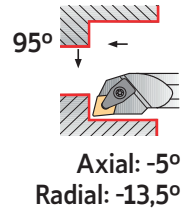

(D) DIMPLE LOCK TOOLHOLDERS

Roughing	Finishing	Medium to Finishing	Medium to Finishing	Medium	Medium
Flat  (12)	MF  (12)	SF  (12)	LC  (12)	MS  (12)	MR  (12)
Medium	Medium	Medium Wiper	Roughing to Medium	Roughing	
PM  (12)	ST  (12)	MW  (12)	SS  (12)	HR  (12)	









Order Code		Reference	Dimensions (mm)							Insert	Kg	Stock	
R	L		D	H	h1	L1	L2	S	A			R	L
212334600	212334700	S25T DCLN R/L 12	25	23	11,5	300	40	17	31	CN.. 1204..	0,700		
212334800	212334900	S32U DCLN R/L 12	32	30	15,0	350	50	22	39	CN.. 1204..	2,050		
212335000	212335100	S40V DCLN R/L 12	40	37	18,5	400	60	27	48	CN.. 1204..	3,750		









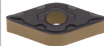

 Stock Items | Itens de stock

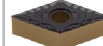
 Available under request | Disponível sob consulta | Disponible bajo consulta

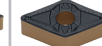
SPARE PARTS || Complementos | Repuestos

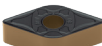
Cutter Reference	Shim	Shim Screw	Spring	Clamp	Clamp Screw	Wrench
S25T DCLN R/L 12						
S32U DCLN R/L 12	CC120300	T06010000	M09513	GA07002	D0602900	SS40
S40V DCLN R/L 12	CC120300	T06010000	M09513	GA07002	D0602900	SS40

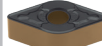
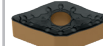
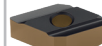
(D) DIMPLE LOCK TOOLHOLDERS

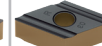
Roughing	Finishing	Medium to Finishing	Medium to Finishing	Medium	Medium	Medium	Medium
Flat	MF	SF	LC	MS	MR	PM	ST
							
(15)	(15)	(15)	(15)	(15)	(15)	(15)	(15)
Medium Wiper	Roughing to Medium	Roughing	Roughing	Roughing to Medium	Medium to Finishing	Medium to Finishing	
MW	SS	HR	RP	O1	O2	O3	
							
(15)	(15)	(15)	(15)	(15)	(15)	(15)	

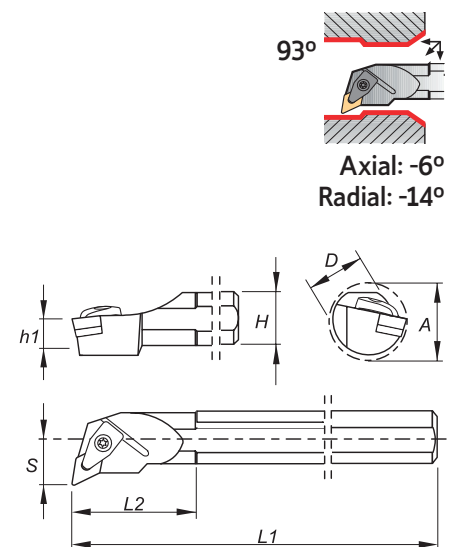







Order Code		Reference	Dimensions (mm)							Insert	Kg	Stock	
R	L		D	H	h1	L1	L2	S	A			R	L
212335200	212335300	S32U DDUN R/L 15	32	30	15,0	350	50	22	39	DN.. 1506..	2,050	○	○
212335400	212335500	S40V DDUN R/L 15	40	37	18,5	400	60	27	48	DN.. 1506..	3,750	○	○

⊗ Stock Items | Itens de stock

○ Available under request | Disponível sob consulta | Disponible bajo consulta

SPARE PARTS | Complementos | Repuestos

Cutter Reference	Shim	Shim Screw	Spring	Clamp	Clamp Screw	Wrench
S32U DDUN R/L 15						
S40V DDUN R/L 15	CD150501	T06010000	M09513	GA07002	D0602900	SS40
	CD150501	T06010000	M09513	GA07002	D0602900	SS40

(M) WEDGE CLAMP SYSTEM



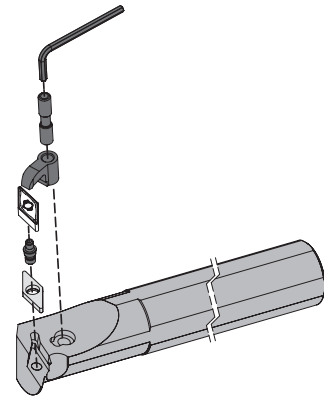
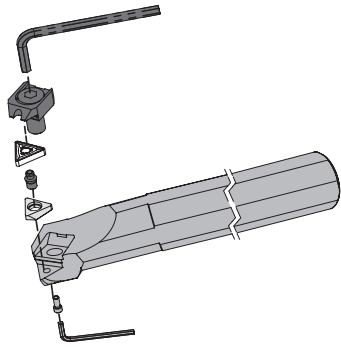

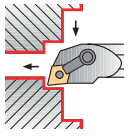
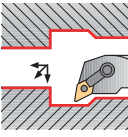
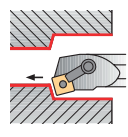
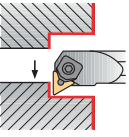
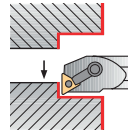
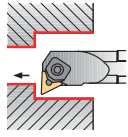
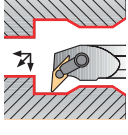
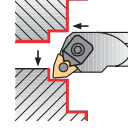
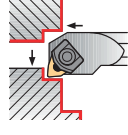





(M-K) DOUBLE LOCK SYSTEM



Negative inserts	MCLN-K 95°  PAGE C - 621 CN.. 1204..	MDUN-K 93°  PAGE C - 622 DN.. 1506..	MSKN-K 75°  PAGE C - 623 SN.. 1204..	MTFN 90°  PAGE C - 624 TN.. 1604.. TN.. 2204..	MTFN-K 90°  PAGE C - 625 TN.. 1604..	MTUN 93°  PAGE C - 626 TN.. 1604.. TN.. 2204..
	Positive inserts	MVUN-K 93°  PAGE C - 627 VN.. 1604..	MWLN 95°  PAGE C - 628 WN.. 0604.. WN.. 0804..	MWLN-K 95°  PAGE C - 629 WN.. 0804..		

- TURNING
- Insert selection
- Overview
- Negative inserts
- Positive inserts
- PCBN & PCD inserts
- Heavy turning
- External Toolholders
- Internal Toolholders
- Automatic Lathes
- Spare Parts
- Technical Data





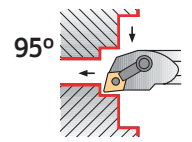

(M-K) DOUBLE LOCK TOOLHOLDERS

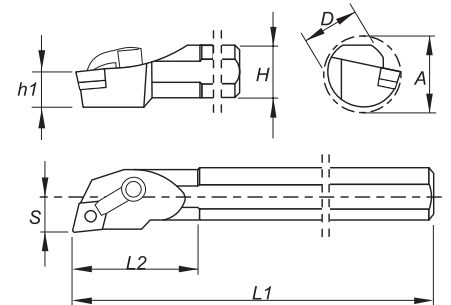
Roughing	Finishing	Medium to Finishing	Medium to Finishing	Medium	Medium
Flat  (12)	MF  (12)	SF  (12)	LC  (12)	MS  (12)	MR  (12)
Medium	Medium	Medium Wiper	Roughing to Medium	Roughing	
PM  (12)	ST  (12)	MW  (12)	SS  (12)	HR  (12)	



Axial: -5°
Radial: -13,5°



Order Code		Reference	Dimensions (mm)							Insert	Kg	Stock	
R	L		D	H	h1	L1	L2	S	A			R	L
212335600	212335700	S25T MCLN R/L 12-K	25	23	11,5	300	33	17	31	CN.. 1204..	0,700		
212335800	212335900	S32U MCLN R/L 12-K	32	30	15,0	350	50	22	39	CN.. 1204..	2,050		
212336000	212336100	S40V MCLN R/L 12-K	40	37	18,5	400	60	27	48	CN.. 1204..	3,750		

 Stock Items | Itens de stock

 Available under request | Disponível sob consulta | Disponible bajo consulta

SPARE PARTS || Complementos | Repuestos





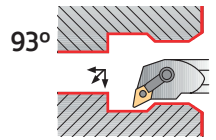



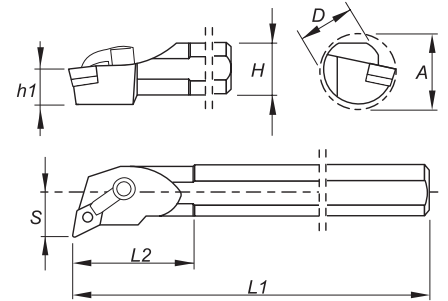





Cutter Reference	Shim	Lock Pin	Lock Pin Punch	Clamp	Differential Screw	Clamp Wrench
S25T MCLN R/L 12-K	-	BS1-402	SS25	GA06000	F0602100	SS30
S32U MCLN R/L 12-K	CC120500	BS1-400	SS25	GA06000	F0602900	SS30
S40V MCLN R/L 12-K	CC120500	BS1-400	SS25	GA06000	F0602900	SS30







(M-K) DOUBLE LOCK TOOLHOLDERS



Axial: -6°
Radial: -12°









Finishing	Medium to Finishing	Medium to Finishing	Medium	Medium	Medium	Medium
MF	SF	LC	MS	MR	PM	ST
						
(15)	(15)	(15)	(15)	(15)	(15)	(15)
Medium Wiper	Roughing to Medium	Roughing	Roughing	Roughing to Medium	Medium to Finishing	Medium to Finishing
MW	SS	HR	RP	O1	O2	O3
						
(15)	(15)	(15)	(15)	(15)	(15)	(15)

Order Code		Reference	Dimensions (mm)							Insert	Kg	Stock	
R	L		D	H	h1	L1	L2	S	A			R	L
212245300	212336200	S25T MDUN R/L 15-K	25	23	11,5	300	40	17	31	DN.. 1506..	0,700		
212336300	212336400	S32U MDUN R/L 15-K	32	30	15,0	350	50	22	39	DN.. 1506..	2,050		
212245400	212336500	S40V MDUN R/L 15-K	40	37	18,5	400	60	27	48	DN.. 1506..	3,750		







 Stock Items | Itens de stock

 Available under request | Disponível sob consulta | Disponible bajo consulta

SPARE PARTS || Complementos | Repuestos

Cutter Reference	Shim	Lock Pin	Lock Pin Punch	Clamp	Differential Screw	Clamp Wrench
S25T MDUN R/L 15-K						
S32U MDUN R/L 15-K	-	BS1-402	SS25	GA06001	F0602100	SS30
S40V MDUN R/L 15-K	CD150501	BS1-401	SS25	GA06001	F0602900	SS30
S40V MDUN R/L 15-K	CD150501	BS1-401	SS25	GA06001	F0602900	SS30

(M-K) DOUBLE LOCK TOOLHOLDERS

Roughing	Finishing	Medium	Medium
Flat  (12)	MF  (12)	SF  (12)	MR  (12)
Medium	Medium	Roughing to Medium	Roughing
PM  (12)	ST  (12)	SS  (12)	HR  (12)

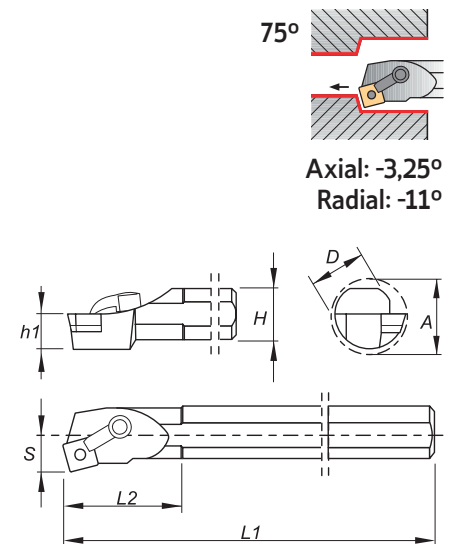













Order Code		Reference	Dimensions (mm)							Insert	Kg	Stock	
R	L		D	H	h1	L1	L2	S	A			R	L
212336600	212336700	S32U MSKN R/L 12-K	32	30	15,0	350	50	22	39	SN.. 1204..	2,050	○	○
212336800	212336900	S40V MSKN R/L 12-K	40	37	18,5	400	60	27	48	SN.. 1204..	3,750	○	○











⊗ Stock Items | Itens de stock

○ Available under request | Disponível sob consulta | Disponible bajo consulta









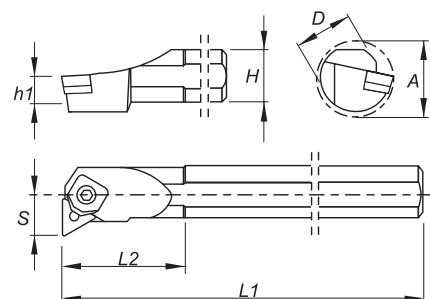
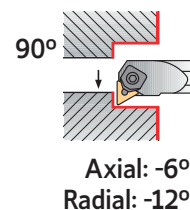







SPARE PARTS || Complementos | Repuestos

Cutter Reference	Shim	Lock Pin	Lock Pin Punch	Clamp	Differential Screw	Clamp Wrench
S32U MSKN R/L 12-K	 CS120500	 BS1-400	 SS25	 GA06000	 F0602900	 SS30
S40V MSKN R/L 12-K	 CS120500	 BS1-400	 SS25	 GA06000	 F0602900	 SS30

(M-K) DOUBLE LOCK TOOLHOLDERS

Roughing	Finishing	Medium to Finishing	Medium to Finishing	Medium	Medium
Flat	MF	SF	LC	MS	MR
 (16-22)	 (16-22)	 (16-22)	 (16-22)	 (16)	 (16-22)
Medium	Medium	Roughing to Medium	Roughing	Medium to Finishing	
PM	ST	SS	HR	O1	
 (16-22)	 (16-22)	 (16-22)	 (16-22)	 (16)	







Order Code		Reference	Dimensions (mm)							Insert	Kg	Stock	
R	L		D	H	h1	L1	L2	S	A			R	L
212050300	212338100	S25T MTFN R/L 16	25	23	11,5	300	40	17	34	TN.. 1604..	0,700		
212168200	212338200	S32U MTFN R/L 16	32	30	15,0	350	50	22	39	TN.. 1604..	2,050		
212338300	212338400	S40V MTFN R/L 16	40	37	18,5	400	60	27	48	TN.. 1604..	3,750		
212338500	212338600	S50W MTFN R/L 16	50	47	23,5	450	65	35	61	TN.. 1604..	6,500		
212421000	212421100	S60Y MTFN R/L 16	60	57	28,5	600	75	43	80	TN.. 1604..	12,600		
212338700	212338800	S40V MTFN R/L 22	40	37	18,5	400	60	27	48	TN.. 2204..	3,750		
212017500	212338900	S50W MTFN R/L 22	50	47	23,5	450	65	35	61	TN.. 2204..	6,500		
212421800	212421900	S60Y MTFN R/L 22	60	57	28,5	600	75	43	80	TN.. 2204..	12,600		











 Stock Items | Itens de stock

 Available under request | Disponível sob consulta | Disponible bajo consulta





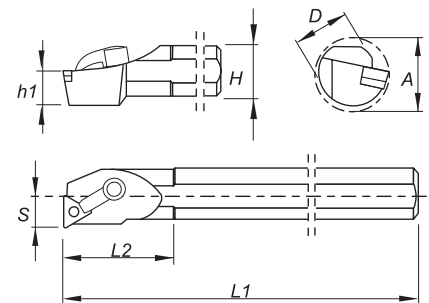
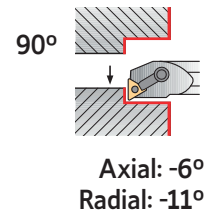

SPARE PARTS || Complementos | Repuestos

Cutter Reference	Shim	Lock Pin	Lock Pin Punch	Wedge Clamp	Wrench
S25T MTFN R/L 16					
S32U MTFN R/L 16	CT160302	BC04501	D0300691	GW08001	SS50
S40V MTFN R/L 16	CT160302	BC04501	D0300700	GW08001	SS50
S50W MTFN R/L 16	CT160302	BC04501	D0300700	GW08001	SS50
S60Y MTFN R/L 16	CT160302	BC04501	D0300691	GW08001	SS50
S40V MTFN R/L 22	CT220500	BC06000	D0400900	GW08003	SS50
S50W MTFN R/L 22	CT220500	BC06000	D0400900	GW08003	SS50
S60Y MTFN R/L 22	CT220500	BC06000	D0400900	GW08003	SS50

(M-K) DOUBLE LOCK TOOLHOLDERS

Roughing	Finishing	Medium to Finishing	Medium to Finishing	Medium	Medium
Flat	MF	SF	LC	MS	MR
 (16-22)	 (16-22)	 (16-22)	 (16-22)	 (16)	 (16-22)
Medium	Medium	Roughing to Medium	Roughing	Medium to Finishing	
PM	ST	SS	HR	O1	
 (16-22)	 (16-22)	 (16-22)	 (16-22)	 (16)	









Order Code		Reference	Dimensions (mm)							Insert	Kg	Stock	
R	L		D	H	h1	L1	L2	S	A			R	L
212337000	212337100	S25T MTFN R/L 16-K	25	23	11,5	300	40	17	31	TN.. 1604..	0,700		
212337200	212337300	S32U MTFN R/L 16-K	32	30	15,0	350	50	22	39	TN.. 1604..	2,050		
212337400	212337500	S40V MTFN R/L 16-K	40	37	18,5	400	60	27	48	TN.. 1604..	3,750		













 Stock Items | Itens de stock

 Available under request | Disponible sob consulta | Disponibile bajo consulta

SPARE PARTS || Complementos | Repuestos

Cutter Reference	Shim	Lock Pin	Lock Pin Wrench	Clamp	Differential Screw	Clamp Wrench
S25T MTFN R/L 16-K						
S32U MTFN R/L 16-K	CT160304	BS05000	SS20	GA06000	F0602900	SS30
S40V MTFN R/L 16-K	CT160304	BS05000	SS20	GA06000	F0602900	SS30





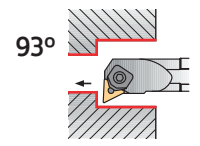



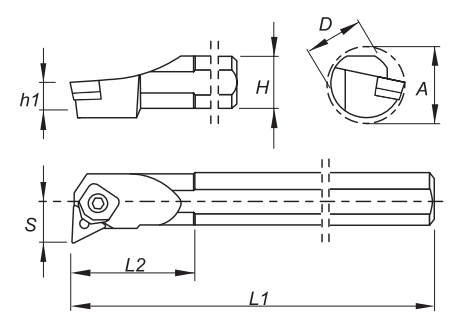



(M) WEDGE CLAMP TOOLHOLDERS

Roughing	Finishing	Medium to Finishing	Medium to Finishing	Medium	Medium
Flat	MF	SF	LC	MS	MR
 (16-22)	 (16-22)	 (16-22)	 (16-22)	 (16)	 (16-22)
Medium	Medium	Medium wiper	Roughing to Medium	Roughing	Medium to Finishing
PM	ST	MW	SS	HR	O1
 (16-22)	 (16-22)	 (16-22)	 (16-22)	 (16-22)	 (16)



Axial: -6°
Radial: -11°







Order Code		Reference	Dimensions (mm)							Insert	Kg	Stock	
R	L		D	H	h1	L1	L2	S	A			R	L
212339000	212339100	S25T MTUN R/L 16	25	23	11,5	300	40	17	34	TN.. 1604..	0,700		
212339200	212339300	S32U MTUN R/L 16	32	30	15,0	350	50	22	39	TN.. 1604..	2,050		
212339400	212339500	S40V MTUN R/L 16	40	37	18,5	400	60	27	48	TN.. 1604..	3,750		
212339600	212339700	S50W MTUN R/L 16	50	47	23,5	450	65	35	61	TN.. 1604..	6,500		
212339800	212339900	S40V MTUN R/L 22	40	37	18,5	400	60	27	48	TN.. 2204..	3,750		
212340000	212340100	S50W MTUN R/L 22	50	47	23,5	450	65	35	61	TN.. 2204..	6,500		









 Stock Items | Itens de stock

 Available under request | Disponível sob consulta | Disponible bajo consulta

SPARE PARTS | Complementos | Repuestos

Cutter Reference	Shim	Lock Pin	Lock Pin Punch	Wedge Clamp	Wrench
S25T MTUN R/L 16	 CT160302	 BC04501	 D0300691	 GW08001	 SS50
S32U MTUN R/L 16	CT160302	BC04501	D0300700	GW08001	SS50
S40V MTUN R/L 16	CT160302	BC04501	D0300700	GW08001	SS50
S50W MTUN R/L 16	CT160302	BC04501	D0300700	GW08001	SS50
S40V MTUN R/L 22	CT220500	BC06000	D0400900	GW08003	SS50
S50W MTUN R/L 22	CT220500	BC06000	D0400900	GW08003	SS50





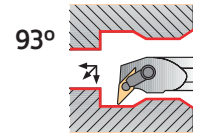

(M-K) DOUBLE LOCK TOOLHOLDERS

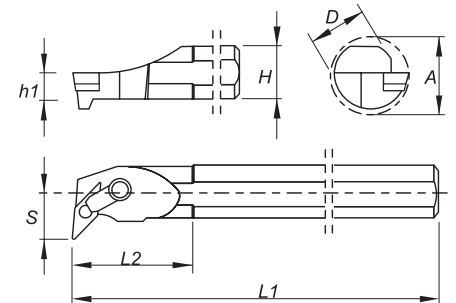
Roughing	Finishing	Medium to Finishing	Medium to Finishing	Medium to Finishing
Flat	MF	SF	LC	MS
 (16)	 (16)	 (16)	 (16)	 (16)
Medium	Medium	Medium	Roughing to Medium	
MR	PM	ST	SS	
 (16)	 (16)	 (16)	 (16)	



Axial: -5°
Radial: -15°

















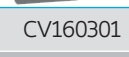



Order Code		Reference	Dimensions (mm)							Insert	Kg	Stock	
R	L		D	H	h1	L1	L2	S	A			R	L
212050400	212337600	S25T MVUN R/L 16-K	25	23	11,5	300	40	17	31	VN.. 1604..	0,700		
212337700	212337800	S32U MVUN R/L 16-K	32	30	15,0	350	50	22	39	VN.. 1604..	2,050		
212337900	212338000	S40V MVUN R/L 16-K	40	37	18,5	400	60	27	48	VN.. 1604..	3,750		

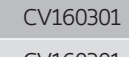









 Stock Items | Itens de stock

 Available under request | Disponível sob consulta | Disponible bajo consulta

SPARE PARTS || Complementos | Repuestos

Cutter Reference	Shim	Lock Pin	Lock Pin Wrench	Clamp	Differential Screw	Clamp Wrench
S25T MVUN R/L 16-K	 CV160301	 BS05000	 SS20	 GA06001	 F0602100	 SS30
S32U MVUN R/L 16-K	 CV160301	 BS05000	 SS20	 GA06001	 F0602900	 SS30
S40V MVUN R/L 16-K	 CV160301	 BS05000	 SS20	 GA06001	 F0602900	 SS30





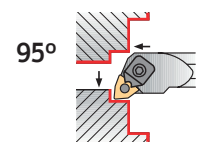



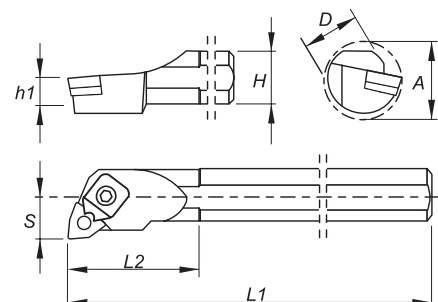







(M) WEDGE CLAMP TOOLHOLDERS

Roughing	Finishing	Medium to Finishing	Medium to Finishing	Medium	Medium
Flat  (08)	MF  (06-08)	SF  (06-08)	LC  (08)	MS  (06-08)	PM  (08)
Medium	Medium	Medium Wiper	Roughing to Medium	Roughing	
MR  (06-08)	ST  (08)	MW  (06-08)	SS  (06-08)	HR  (08)	



Axial: -5°
Radial: -11,5°







Order Code		Reference	Dimensions (mm)							Insert	Kg	Stock	
R	L		D	H	h1	L1	L2	S	A			R	L
212050500	212340200	S20S MWLN R/L 06	20	18	9,0	250	36	13	27	WN.. 0604..	0,550		
212340300	212340400	S25T MWLN R/L 06	25	23	11,5	300	40	17	31	WN.. 0604..	0,700		
212340500	212340600	S32U MWLN R/L 06	32	30	15,0	350	50	22	39	WN.. 0604..	2,050		
212054400	212340700	S25T MWLN R/L 08	25	23	11,5	300	40	17	31	WN.. 0804..	0,700		
212044100	212044000	S32U MWLN R/L 08	32	30	15,0	350	50	22	39	WN.. 0804..	2,050		
212340800	212340900	S40V MWLN R/L 08	40	37	18,5	400	60	27	48	WN.. 0804..	3,750		
212341000	212341100	S50W MWLN R/L 08	50	47	23,5	450	65	35	61	WN.. 0804..	6,500		
212421200	212421300	S60Y MWLN R/L 08	60	57	28,5	600	75	43	80	WNM. 0804..	12,600		







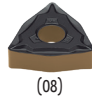

 Stock Items | Itens de stock

 Available under request | Disponível sob consulta | Disponible bajo consulta

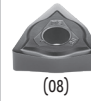
SPARE PARTS | Complementos | Repuestos

Cutter Reference	Shim 	Lock Pin 	Lock Pin Punch 	Wedge Clamp 	Wrench 
S20S MWLN R/L 06	-	BC04502	D0300691	GW05000	SS25
S25T MWLN R/L 06	CW060300	BC04501	D0300691	GW05000	SS25
S32U MWLN R/L 06	CW060300	BC04501	D0300691	GW05000	SS25
S25T MWLN R/L 08	-	BC06001	D0400691	GW08000	SS25
S32U MWLN R/L 08	CW080500	BC06000	D0400691	GW08000	SS25
S40V MWLN R/L 08	CW080500	BC06000	D0400691	GW08000	SS25
S50W MWLN R/L 08	CW080500	BC06000	D0400691	GW08000	SS25
S60Y MWLN R/L 08	CW080500	BC06000	D0400691	GW08000	SS25

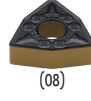

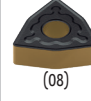

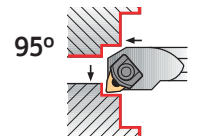

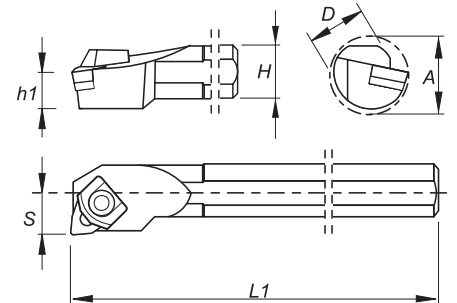

(M-K) DOUBLE LOCK TOOLHOLDERS

Roughing	Finishing	Medium to Finishing	Medium to Finishing	Medium	Medium
Flat	MF	SF	LC	MS	PM
 (08)	 (08)	 (08)	 (08)	 (08)	 (08)
Medium	Medium	Medium Wiper	Roughing to Medium	Roughing	
MR	ST	MW	SS	HR	
 (08)	 (08)	 (08)	 (08)	 (08)	



Axial: -5°
Radial: -11,5°







Order Code		Reference	Dimensions (mm)							Insert	Kg	Stock	
R	L		D	H	h1	L1	L2	S	A			R	L
212341200	212341300	S25T MWLN R/L 08-K	25	23	11,5	300	40	17	31	WN.. 0804..	0,700		
212341400	212341500	S32U MWLN R/L 08-K	32	30	15,0	350	50	22	39	WN.. 0804..	2,050		
212341600	212341700	S40V MWLN R/L 08-K	40	37	18,5	400	60	27	48	WN.. 0804..	3,750		
212341800	212341900	S50W MWLN R/L 08-K	50	47	23,5	450	65	35	61	WN.. 0804..	6,500		

 Stock Items | Itens de stock

 Available under request | Disponível sob consulta | Disponible bajo consulta

SPARE PARTS || Complementos | Repuestos





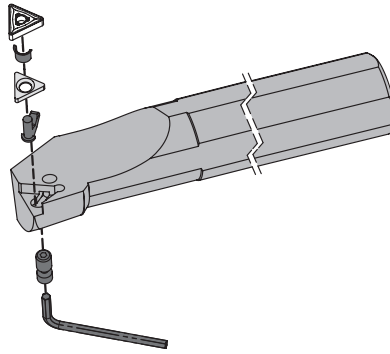









Cutter Reference	Shim	Lock Pin	Lock Pin Screw	Wedge Clamp	Wrench
S25T MWLN R/L 08-K	-				
S32U MWLN R/L 08-K	CW080500	BC06001	D0400691	GW06000	SS25
S40V MWLN R/L 08-K	CW080500	BC06000	D0400691	GW06000	SS25
S50W MWLN R/L 08-K	CW080500	BC06000	D0400691	GW06000	SS25

(P) LEVER LOCK SYSTEM



<p>PCKN 75°</p> <p>PAGE C - 631 CN.. 1204.. CN.. 1606.. CN.. 1906..</p>	<p>PCLN 95°</p> <p>PAGE C - 632 CN.. 0903.. ... CN.. 1906..</p>	<p>A-PCLN 95°</p> <p>PAGE C - 633 CN.. 0903.. ... CN.. 1204..</p>	<p>PDUN 93°</p> <p>PAGE C - 634 DN.. 1104.. DN.. 1506..</p>	<p>A-PDUN 93°</p> <p>PAGE C - 635 DN.. 1104.. DN.. 1506..</p>	<p>PDUN 93° - BT</p> <p>PAGE C - 636 DN.. 1506..</p>
<p>PSKN 75°</p> <p>PAGE C - 637 SN.. 1204.. SN.. 1906..</p>	<p>A-PSKN 75°</p> <p>PAGE C - 638 SN.. 1204..</p>	<p>A-PSSN 45°</p> <p>PAGE C - 639 SN.. 1204..</p>	<p>PTFN 90°</p> <p>PAGE C - 640 TN.. 1604.. TN.. 2204..</p>	<p>A-PTFN 90°</p> <p>PAGE C - 641 TN.. 1604.. TN.. 2204..</p>	<p>PWLN 95°</p> <p>PAGE C - 642 WN.. 0604.. WN.. 0804..</p>
<p>A-PWLN 95°</p> <p>PAGE C - 643 WN.. 0604.. WN.. 0804..</p>					

(P) LEVER LOCK TOOLHOLDERS

Roughing	Finishing	Medium to Finishing	Medium to Finishing	Medium	Medium	Medium
Flat  (12-16-19)	MF  (12)	SF  (12)	LC  (12)	MS  (12)	MR  (12-16-19)	PM  (12)
Medium	Medium Wiper	Roughing to Medium	Roughing	Roughing	Heavy to Roughing	Heavy to Roughing
ST  (12-19)	MW  (12)	SS  (12-16-19)	HR  (12-16-19)	RP  (19)	HY  (19)	HZ  (19)

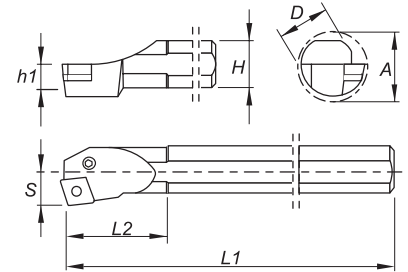
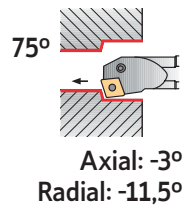

Order Code		Reference	Dimensions (mm)							Insert	Kg	Stock	
R	L		D	H	h1	L1	L2	S	A			R	L
212342000	212342100	S25T PCKN R/L 12	25	23	11,5	300	40	17	31	CN.. 1204..	0,700	⊗	⊗
212342200	212342300	S32U PCKN R/L 12	32	30	15,0	350	50	22	39	CN.. 1204..	2,050	○	○
212342400	212342500	S40V PCKN R/L 12	40	37	18,5	400	60	27	48	CN.. 1204..	3,750	○	○
212421400	212421500	S50W PCKN R/L 12	50	47	23,5	450	60	35	61	CN.. 1204..	6,500	○	○
212421600	212421700	S60Y PCKN R/L 12	60	57	28,5	600	75	43	80	CN.. 1204..	12,600	○	○
212342600	212342700	S50W PCKN R/L 16	50	47	23,5	450	65	35	61	CN.. 1606..	6,500	○	○
212422000	212422100	S60Y PCKN R/L 16	60	57	28,5	600	75	43	80	CN.. 1606..	12,600	○	○
212342800	212342900	S50W PCKN R/L 19	50	47	23,5	450	65	35	61	CN.. 1906..	6,500	○	○
212422200	212422300	S60Y PCKN R/L 19	60	57	28,5	600	75	43	80	CN.. 1906..	12,600	○	○

⊗ Stock Items | Itens de stock

○ Available under request | Disponível sob consulta | Disponible bajo consulta

SPARE PARTS | Complementos | Repuestos

Cutter Reference	Order separately					
	Shim	Shim Pin	Shim Pin Punch	Lever	Lever Screw	Wrench
S25T PCKN R/L 12	-	-	-	AN12100	PA0601300	SS25
S32U PCKN R/L 12	CC120301	BE05500	BF47509	AC13200	PA0801700	SS30
S40V PCKN R/L 12	CC120301	BE05500	BF47509	AN13100	PA0802100	SS30
S50W PCKN R/L 12	CC120301	BE05500	BF47509	AN13100	PA0802100	SS30
S60Y PCKN R/L 12	CC120301	BE05500	BF47509	AN13100	PA0802100	SS30
S50W PCKN R/L 16	CC160500	BE07000	BF65012	AN17100	PA0802300	SS30
S60Y PCKN R/L 16	CC160500	BE07000	BF65012	AN17100	PA0802300	SS30
S50W PCKN R/L 19	CC190500	BE08500	BF80012	AN20800	PA1002700	SS40
S60Y PCKN R/L 19	CC190500	BE08500	BF0012	AN20800	PA1002700	SS40

C
TURNING
Insert selection
Overview
Negative inserts
Positive inserts
PCBN & PCD inserts
Heavy turning
External Toolholders
Internal Toolholders
Automatic Lathes
Spare Parts
Technical Data

(P) LEVER LOCK TOOLHOLDERS

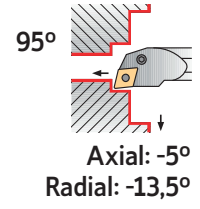

Roughing	Finishing	Medium to Finishing	Medium to Finishing	Medium	Medium	Medium
Flat	MF	SF	LC	MS	MR	PM
(09-12-16-19)	(09-12)	(12)	(12)	(12)	(09-12-16-19)	(12)
Medium	Medium Wiper	Roughing to Medium	Roughing	Roughing	Heavy to Roughing	Heavy to Roughing
ST	MW	SS	HR	RP	HY	HZ
(09-12-16-19)	(12)	(09-12-16-19)	(12-16-19)	(19)	(19)	(19)

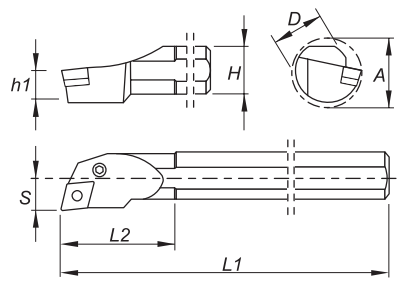











Order Code		Reference	Dimensions (mm)							Insert	Kg	Stock	
R	L		D	H	h1	L1	L2	S	A			R	L
212247000	212343000	S16R PCLN R/L 09	16	15	7,5	200	26	11	20	CN.. 0903..	0,300	⊗	⊗
212050600	212343100	S20S PCLN R/L 09	20	18	9,0	250	29	13	25	CN.. 0903..	0,550	⊗	⊗
212247100	212343200	S25T PCLN R/L 09	25	23	11,5	300	33	17	32	CN.. 0903..	0,700	⊗	⊗
212048400	212343300	S25T PCLN R/L 12	25	23	11,5	300	40	17	31	CN.. 1204..	0,700	⊗	⊗
212169900	212343400	S32U PCLN R/L 12	32	30	15,0	350	50	22	39	CN.. 1204..	2,050	○	○
212247200	212017300	S40V PCLN R/L 12	40	37	18,5	400	60	27	48	CN.. 1204..	3,750	○	○
212343500	212343600	S50W PCLN R/L 12	50	47	23,5	450	65	35	61	CN.. 1204..	6,500	○	○
212423300	212423400	S60Y PCLN R/L 12	60	57	28,5	600	75	43	80	CN.. 1204..	12,600	○	○
212423500	212423600	S40V PCLN R/L 16	40	37	18,5	400	50	27	48	CN.. 1606..	3,750	○	○
212017700	212343700	S50W PCLN R/L 16	50	47	23,5	450	65	35	61	CN.. 1606..	6,500	○	○
212423700	212423800	S60Y PCLN R/L 16	60	57	28,5	600	75	43	80	CN.. 1606..	12,600	○	○
212017800	212017600	S50W PCLN R/L 19	50	47	23,5	450	65	35	61	CN.. 1906..	6,500	○	○
212423900	212424000	S60Y PCLN R/L 19	60	57	28,5	600	75	43	80	CN.. 1906..	12,600	○	○

⊗ Stock Items | Itens de stock ○ Available under request | Disponível sob consulta | Disponible bajo consulta









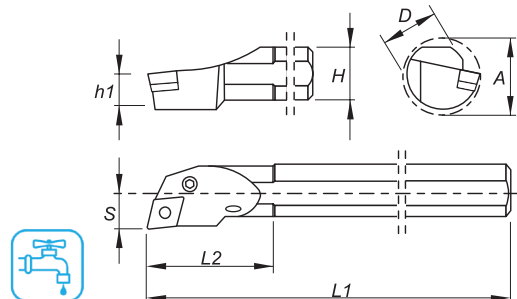
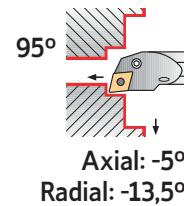

SPARE PARTS | Complementos | Repuestos

Cutter Reference	Order separately					
	Shim	Shim Pin	Shim Pin Punch	Lever	Lever Screw	Wrench
S16R PCLN R/L 09	-	-	-	AN07800	PA0501200	SS20
S20S PCLN R/L 09	-	-	-	AN07800	PA0501200	SS20
S25T PCLN R/L 09	CC090300	BE04400	BF40009	AN01200	PA0601300	SS25
S25T PCLN R/L 12	-	-	-	AN12100	PA0601300	SS25
S32U PCLN R/L 12	CC120301	BE05500	BF47509	AC13200	PA0801700	SS30
S40V PCLN R/L 12	CC120301	BE05500	BF47509	AN13100	PA0802100	SS30
S50W PCLN R/L 12	CC120301	BE05500	BF47509	AN13100	PA0802100	SS30
S60Y PCLN R/L 12	CC120301	BE05500	BF47509	AN13100	PA0802100	SS30
S40V PCLN R/L 16	CC160500	BE07000	BF65012	AN17100	PA0802300	SS30
S50W PCLN R/L 16	CC160500	BE07000	BF65012	AN17100	PA0802300	SS30
S60Y PCLN R/L 16	CC160500	BE07000	BF65012	AN17100	PA0802300	SS30
S50W PCLN R/L 19	CC190500	BE08300	BF80012	AN20200	PA1002700	SS40
S60Y PCLN R/L 19	CC190500	BE08300	BF80012	AN20200	PA1002700	SS40

(P) LEVER LOCK TOOLHOLDERS

Roughing	Finishing	Medium to Finishing	Medium to Finishing	Medium	Medium
Flat  (09-12)	MF  (09-12)	SF  (12)	LC  (12)	MS  (12)	MR  (09-12)
Medium	Medium	Medium Wiper	Roughing to Medium	Roughing	
PM  (12)	ST  (09-12)	MW  (12)	SS  (09-12)	HR  (12)	









Order Code		Reference	Dimensions (mm)							Insert	Kg	Stock	
R	L		D	H	h1	L1	L2	S	A			R	L
212343800	212343900	A16M PCLN R/L 09	16	15	7,5	150	26	11	20	CN.. 0903..	0,200		
212344000	212344100	A20Q PCLN R/L 09	20	18	9,0	180	29	13	25	CN.. 0903..	0,400		
212344200	212344300	A25R PCLN R/L 12	25	23	11,5	200	40	17	31	CN.. 1204..	0,700		
212344400	212344500	A32S PCLN R/L 12	32	30	15,0	250	50	22	39	CN.. 1204..	1,400		
212344600	212344700	A40T PCLN R/L 12	40	37	18,5	300	60	27	48	CN.. 1204..	2,650		

 Stock Items | Itens de stock

 Available under request | Disponível sob consulta | Disponible bajo consulta

SPARE PARTS | Complementos | Repuestos

Cutter Reference	Order separately					
	Shim	Shim Pin	Shim Pin Punch	Lever	Lever Screw	Wrench
A16M PCLN R/L 09						
A20Q PCLN R/L 09	-	-	-	AN07800	PA0501200	SS20
A25R PCLN R/L 12	-	-	-	AN12100	PA0601300	SS25
A32S PCLN R/L 12	CC120301	BE05500	BF47509	AC13200	PA0801700	SS30
A40T PCLN R/L 12	CC120301	BE05500	BF47509	AN13100	PA0802100	SS30

(P) LEVER LOCK TOOLHOLDERS

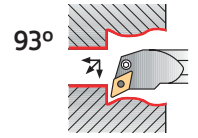

Axial: -6°
Radial: -14°

Roughing	Finishing	Medium to Finishing	Medium to Finishing	Medium	Medium	Medium	Medium
Flat	MF	SF	LC	MS	MR	PM	ST
 (11-15)	 (11-15)	 (11-15)	 (15)	 (15)	 (11-15)	 (15)	 (11-15)
Medium Wiper	Roughing to Medium	Roughing	Roughing	Roughing to Medium	Medium to Finishing	Medium to Finishing	
MW	SS	HR	RP	O1	O2	O3	
 (15)	 (11-15)	 (15)	 (15)	 (15)	 (15)	 (15)	

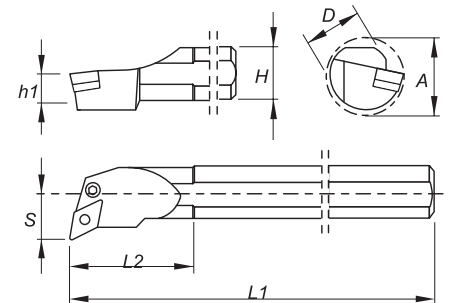

Order Code		Reference	Dimensions (mm)							Insert	Kg	Stock	
R	L		D	H	h1	L1	L2	S	A			R	L
212079300	212344800	S25T PDUN R/L 11	25	23	11,5	300	35	17	32	DN.. 1104..	0,700		
212247300	212344900	S32U PDUN R/L 11	32	30	15,0	350	40	22	40	DN.. 1104..	2,050		
212079400	212079500	S32U PDUN R/L 15	32	30	15,0	350	50	22	39	DN.. 1506..	2,050		
212345000	212345100	S40V PDUN R/L 15	40	37	18,5	400	60	27	48	DN.. 1506..	3,750		
212018000	212017900	S50W PDUN R/L 15	50	47	23,5	450	65	35	61	DN.. 1506..	6,500		











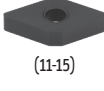
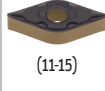
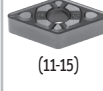

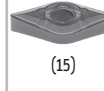
Stock Items | Itens de stock

Available under request | Disponível sob consulta | Disponible bajo consulta

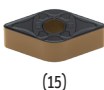

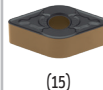

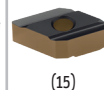

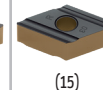
SPARE PARTS || Complementos | Repuestos

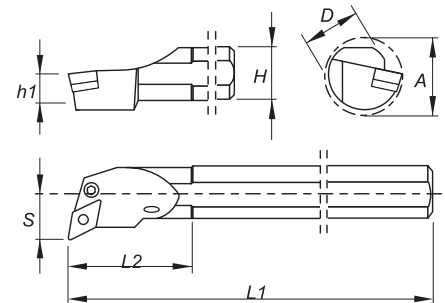
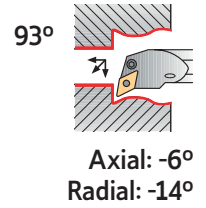
Cutter Reference	Order separately						for inserts DN.. 1504..	
	Shim	Shim Pin	Shim Pin Punch	Lever	Lever Screw	Wrench	Shim	Shim Pin
S25T PDUN R/L 11	 CD110300	 BE04400	 BF40009	 AN01200	 PA0601700	 SS25	-	-
S32U PDUN R/L 11	 CD110300	 BE04400	 BF40009	 AN01200	 PA0601700	 SS25	-	-
S32U PDUN R/L 15	 CD150300	 BE05500	 BF47509	 AN14700	 PA0801700	 SS30	CD150500	BE05401
S40V PDUN R/L 15	 CD150300	 BE05500	 BF47509	 AN14700	 PA0802101	 SS30	CD150500	BE05401
S50W PDUN R/L 15	 CD150300	 BE05500	 BF47509	 AN14700	 PA0802101	 SS30	CD150500	BE05401

(P) LEVER LOCK TOOLHOLDERS

Roughing	Finishing	Medium to Finishing	Medium to Finishing	Medium	Medium	Medium	Medium
Flat	MF	SF	LC	MS	MR	PM	ST
 (11-15)	 (11-15)	 (11-15)	 (15)	 (15)	 (11-15)	 (15)	 (11-15)
Medium Wiper	Roughing to Medium	Roughing	Roughing	Roughing to Medium	Medium to Finishing	Medium to Finishing	
MW	SS	HR	RP	O1	O2	O3	
 (15)	 (11-15)	 (15)	 (15)	 (15)	 (15)	 (15)	





Order Code		Reference	Dimensions (mm)							Insert	Kg	Stock	
R	L		D	H	h1	L1	L2	S	A			R	L
212345200	212345300	A25R PDUN R/L 11	25	23	11,5	200	40	17	31	DN.. 1104..	0,700		
212345400	212345500	A32S PDUN R/L 15	32	30	15,0	250	50	22	39	DN.. 1506..	1,400		
212345600	212345700	A40T PDUN R/L 15	40	37	18,5	300	60	27	48	DN.. 1506..	2,650		

 Stock Items | Itens de stock

 Available under request | Disponível sob consulta | Disponible bajo consulta

SPARE PARTS | Complementos | Repuestos



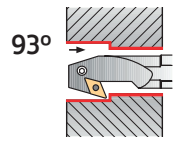

Cutter Reference	Order separately						for inserts DN.. 1504..	
	Shim	Shim Pin	Shim Pin Punch	Lever	Lever Screw	Wrench	Shim	Shim Pin
A25R PDUN R/L 11							-	-
A32S PDUN R/L 15	CD150300	BE05500	BF47509	AN14700	PA0801700	SS30	CD150500	BE05401
A40T PDUN R/L 15	CD150300	BE05500	BF47509	AN14700	PA0802101	SS30	CD150500	BE05401

C
TURNING
Insert selection
Overview
Negative inserts
Positive inserts
PCBN & PCD inserts
Heavy turning
External Toolholders
Internal Toolholders
Automatic Lathes
Spare Parts
Technical Data

(P) LEVER LOCK TOOLHOLDERS

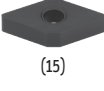
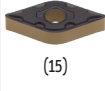
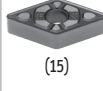
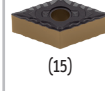
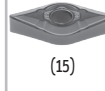

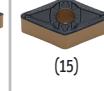
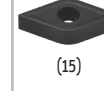
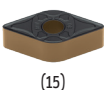
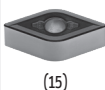
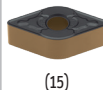
Axial: -6°
Radial: -14°

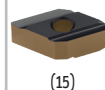
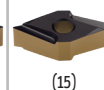
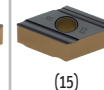
Roughing	Finishing	Medium to Finishing	Medium to Finishing	Medium	Medium	Medium	Medium
Flat	MF	SF	LC	MS	MR	PM	ST
 (15)	 (15)	 (15)	 (15)	 (15)	 (15)	 (15)	 (15)
Medium Wiper	Roughing to Medium	Roughing	Roughing	Roughing to Medium	Medium to Finishing	Medium to Finishing	
MW	SS	HR	RP	O1	O2	O3	
 (15)	 (15)	 (15)	 (15)	 (15)	 (15)	 (15)	

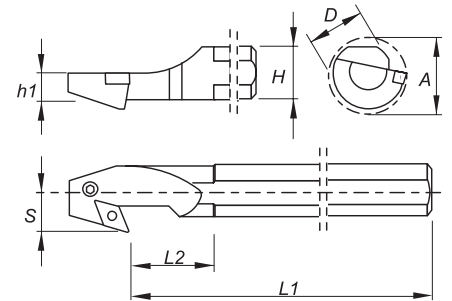

Order Code		Reference	Dimensions (mm)							Insert	Kg	Stock	
R	L		D	H	h1	L1	L2	S	A			R	L
212345800	212345900	S32U PDUN R/L 15-BT	32	30	15,0	350	50	22	39	DN.. 1506..	2,050	○	○
212346000	212346100	S40V PDUN R/L 15-BT	40	37	18,5	400	60	27	48	DN.. 1506..	3,750	○	○
212346200	212346300	S50W PDUN R/L 15-BT	50	47	23,5	450	65	35	61	DN.. 1506..	6,500	○	○









⊗ Stock Items | Itens de stock

○ Available under request | Disponível sob consulta | Disponible bajo consulta

SPARE PARTS || Complementos | Repuestos

Cutter Reference	Order separately						for inserts DN.. 1504..	
	Shim	Shim Pin	Shim Pin Punch	Lever	Lever Screw	Wrench	Shim	Shim Pin
S32U PDUN R/L 15-BT	-	-	-	AN14700	PA0801700	SS30	-	-
S40V PDUN R/L 15-BT	CD150300	BE05500	BF47509	AN14700	PA0802101	SS30	CD150500	BE05401
S50W PDUN R/L 15-BT	CD150300	BE05500	BF47509	AN14700	PA0802101	SS30	CD150500	BE05401

(P) LEVER LOCK TOOLHOLDERS

Roughing	Finishing	Medium	Medium	Medium	Medium
Flat  (12-19)	MF  (12)	SF  (12)	MR  (12-19)	PM  (12)	ST  (12-19)
Roughing to Medium	Roughing	Roughing	Heavy to Roughing	Heavy to Roughing	
SS  (12-19)	HR  (12-19)	RP  (15-19)	HY  (19)	HZ  (19)	

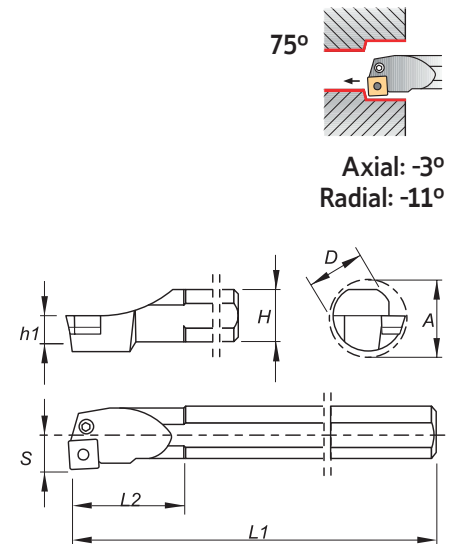

Order Code		Reference	Dimensions (mm)							Insert	Kg	Stock	
R	L		D	H	h1	L1	L2	S	A			R	L
212050700	212346400	S25T PSKN R/L 12	25	23	11,5	300	40	17	31	SN.. 1204..	0,700	⊗	⊗
212346500	212346600	S32U PSKN R/L 12	32	30	15,0	350	50	22	39	SN.. 1204..	2,050	○	○
212346700	212346800	S40V PSKN R/L 12	40	37	18,5	400	60	27	48	SN.. 1204..	3,750	○	○
212424100	212424200	S40V PSKN R/L 15	40	37	18,5	400	50	27	48	SN.. 1506..	3,750	○	○
212424300	212424400	S50W PSKN R/L 15	50	47	23,5	450	60	35	61	SN.. 1506..	6,500	○	○
212346900	212347000	S50W PSKN R/L 19	50	47	23,5	450	65	35	61	SN.. 1906..	6,500	○	○
212424500	212424600	S60Y PSKN R/L 19	60	57	28,5	600	75	43	80	SN.. 1906..	12,600	○	○

⊗ Stock Items | Itens de stock









○ Available under request | Disponível sob consulta | Disponible bajo consulta

SPARE PARTS | Complementos | Repuestos

Cutter Reference	Order separately					
	Shim	Shim Pin	Shim Pin Punch	Lever	Lever Screw	Wrench
S25T PSKN R/L 12	-	-	-	AN12100	PA0601300	SS25
S32U PSKN R/L 12	CS120302	BE05500	BF47509	AC13200	PA0801700	SS30
S40V PSKN R/L 12	CS120302	BE05500	BF47509	AN13100	PA0802100	SS30
S40V PSKN R/L 15	CS150400	BE07000	BF65012	AN17100	PA0802300	SS30
S50W PSKN R/L 15	CS150400	BE07000	BF65012	AN17100	PA0802300	SS30
S50W PSKN R/L 19	CS190400	BE08300	BF80012	AN20200	PA1003000	SS40
S60Y PSKN R/L 19	CS150400	BE08300	BF80012	AN20200	PA1003000	SS40

C
TURNING
Insert selection
Overview
Negative inserts
Positive inserts
PCBN & PCD inserts
Heavy turning
External Toolholders
Internal Toolholders
Automatic Lathes
Spare Parts
Technical Data





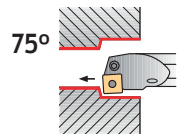

(P) LEVER LOCK TOOLHOLDERS

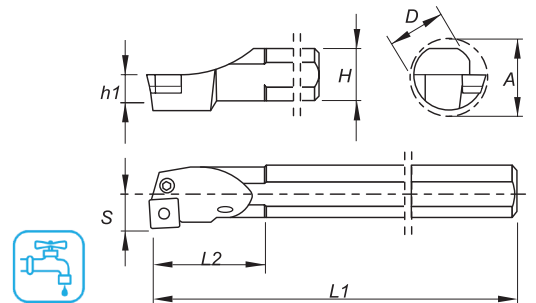
Roughing	Finishing	Medium	Medium
Flat	MF	SF	MR
 (12)	 (12)	 (12)	 (12)
Medium	Medium	Roughing to Medium	Roughing
PM	ST	SS	HR
 (12)	 (12)	 (12)	 (12)



Axial: -3°
Radial: -11°



Order Code		Reference	Dimensions (mm)							Insert	Kg	Stock	
R	L		D	H	h1	L1	L2	S	A			R	L
212347100	212347200	A25R PSKN R/L 12	25	23	11,5	200	40	17	31	SN.. 1204..	0,700		
212347300	212347400	A32S PSKN R/L 12	32	30	15,0	250	50	22	39	SN.. 1204..	1,400		
212347500	212347600	A40T PSKN R/L 12	40	37	18,5	300	60	27	48	SN.. 1204..	2,650		









 Stock Items | Itens de stock

Available under request | Disponível sob consulta | Disponible bajo consulta





SPARE PARTS || Complementos | Repuestos

Cutter Reference	Order separately					
	Shim	Shim Pin	Shim Pin Punch	Lever	Lever Screw	Wrench
A25R PSKN R/L 12	-	-	-	AN12100	PA0601300	SS25
A32S PSKN R/L 12	CS120302	BE05500	BF47509	AC13200	PA0801700	SS30
A40T PSKN R/L 12	CS120302	BE05500	BF47509	AN13100	PA0802100	SS30

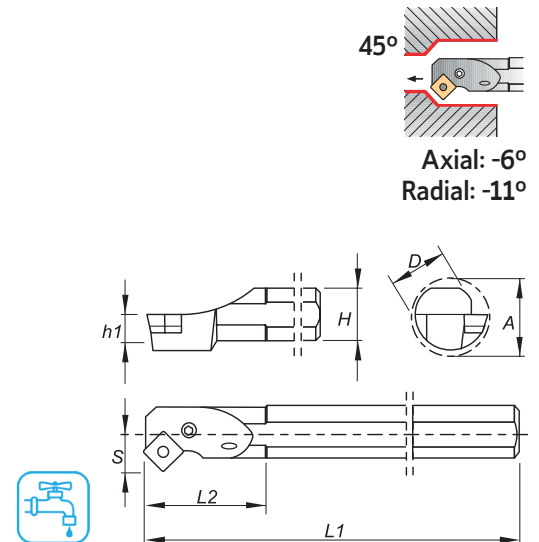
(P) LEVER LOCK TOOLHOLDERS

Roughing	Finishing	Medium	Medium
Flat  (12)	MF  (12)	SF  (12)	MR  (12)
Medium	Medium	Roughing to Medium	Roughing
PM  (12)	ST  (12)	SS  (12)	HR  (12)









Order Code		Reference	Dimensions (mm)							Insert	Kg	Stock	
R	L		D	H	h1	L1	L2	S	A			R	L
212347700	212347800	A25R PSSN R/L 12	25	23	11,5	200	40	17	31	SN.. 1204..	0,700		
212347900	212348000	A32S PSSN R/L 12	32	30	15,0	250	50	22	39	SN.. 1204..	2,050		











 Stock Items | Itens de stock

 Available under request | Disponível sob consulta | Disponible bajo consulta









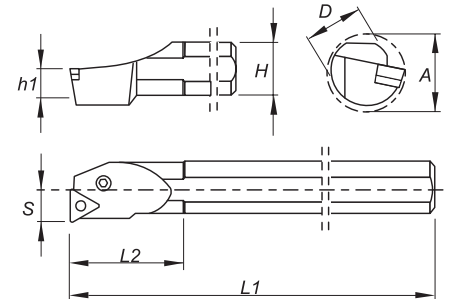
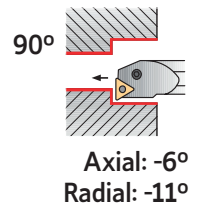



SPARE PARTS || Complementos | Repuestos

Cutter Reference	Order separately					
	Shim	Shim Pin	Shim Pin Punch	Lever	Lever Screw	Wrench
A25R PSKN R/L 12						
A32S PSKN R/L 12	-	-	-	AN12100	PA0601300	SS25
A32S PSKN R/L 12	CS120302	BE05500	BF47509	AC13200	PA0801700	SS30

(P) LEVER LOCK TOOLHOLDERS

Roughing	Finishing	Medium to Finishing	Medium to Finishing	Medium	Medium
Flat	MF	SF	LC	MS	MR
 (16-22)	 (16-22)	 (16-22)	 (16-22)	 (16)	 (16-22)
Medium	Medium	Roughing to Medium	Roughing	Medium to Finishing	
PM	ST	SS	HR	O1	
 (16-22)	 (16-22)	 (16-22)	 (16-22)	 (16)	









Order Code		Reference	Dimensions (mm)							Insert	Kg	Stock	
R	L		D	H	h1	L1	L2	S	A			R	L
212054300	212348100	S25T PTFN R/L 16	25	23	11,5	300	40	17	31	TN.. 1604..	0,700		
212045000	212348200	S32U PTFN R/L 16	32	30	15,0	350	50	22	39	TN.. 1604..	2,050		
212424700	212424800	S40V PTFN R/L 16	40	37	18,5	400	50	27	48	TN.. 1604..	3,750		
212424900	212425000	S50W PTFN R/L 16	50	47	23,5	450	60	35	61	TN.. 1604..	6,500		
212348300	212348400	S40V PTFN R/L 22	40	37	18,5	400	60	27	48	TN.. 2204..	3,750		
212348500	212348600	S50W PTFN R/L 22	50	47	23,5	450	65	35	61	TN.. 2204..	6,500		











 Stock Items | Itens de stock

 Available under request | Disponible sob consulta | Disponible bajo consulta





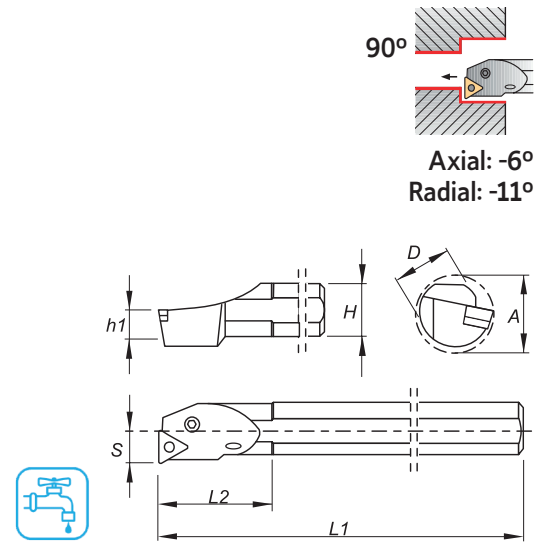

SPARE PARTS | Complementos | Repuestos

Cutter Reference	Order separately					
	Shim	Shim Pin	Shim Pin Punch	Lever	Lever Screw	Wrench
S25T PTFN R/L 16						
S32U PTFN R/L 16	-	-	-	AN09500	PA0501200	SS20
S40V PTFN R/L 16	CT160303	BE04400	BF40009	AN01200	PA0601700	SS25
S50W PTFN R/L 16	CT160303	BE04400	BF40009	AN01200	PA0601700	SS25
S40V PTFN R/L 22	CT220302	BE05500	BF47509	AN13100	PA0802100	SS30
S50W PTFN R/L 22	CT220302	BE05500	BF47509	AN13100	PA0802100	SS30

(P) LEVER LOCK TOOLHOLDERS

Roughing	Finishing	Medium to Finishing	Medium to Finishing	Medium	Medium
Flat	MF	SF	LC	MS	MR
 (16-22)	 (16-22)	 (16-22)	 (16-22)	 (16)	 (16-22)
Medium	Medium	Roughing to Medium	Roughing	Medium to Finishing	
PM	ST	SS	HR	O1	
 (16-22)	 (16-22)	 (16-22)	 (16-22)	 (16)	









Order Code		Reference	Dimensions (mm)							Insert	Kg	Stock	
R	L		D	H	h1	L1	L2	S	A			R	L
212348700	212348800	A25R PTFN R/L 16	25	23	11,5	200	40	17	31	TN.. 1604..	0,700		
212348900	212349000	A32S PTFN R/L 16	32	30	15,0	250	50	22	39	TN.. 1604..	1,400		
212349100	212349200	A40T PTFN R/L 22	40	37	18,5	300	60	27	48	TN.. 2204..	2,650		

 Stock Items | Itens de stock

 Available under request | Disponível sob consulta | Disponible bajo consulta

SPARE PARTS || Complementos | Repuestos

Cutter Reference	Order separately					
	Shim	Shim Pin	Shim Pin Punch	Lever	Lever Screw	Wrench
A25R PTFN R/L 16						
A25R PTFN R/L 16	-	-	-	AN09500	PA0501200	SS20
A32S PTFN R/L 16	CT160303	BE04400	BF40009	AN01200	PA0601700	SS25
A40T PTFN R/L 22	CT220302	BE05500	BF47509	AN13100	PA0802100	SS30

(P) LEVER LOCK TOOLHOLDERS

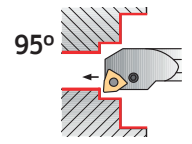

95°
Axial: -6°
Radial: -13,5°

Roughing	Finishing	Medium to Finishing	Medium to Finishing	Medium	Medium
Flat (06-08)	MF (06-08)	SF (06-08)	LC (08)	MS (06-08)	PM (08)
Medium	Medium	Medium Wiper	Roughing to Medium	Roughing	
MR (06-08)	ST (08)	MW (06-08)	SS (06-08)	HR (08)	

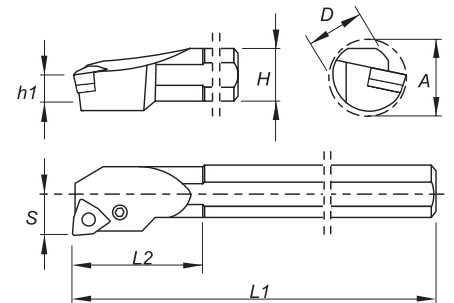

Order Code		Reference	Dimensions (mm)							Insert	Kg	Stock	
R	L		D	H	h1	L1	L2	S	A			R	L
212046300	212349300	S16R PWLN R/L 06	16	15	7,5	200	24	11	20	WN..0604..	0,300		
212219100	212349400	S20S PWLN R/L 06	20	18	9,0	250	36	13	27	WN..0604..	0,550		
212249900	212349500	S25T PWLN R/L 06	25	23	11,5	300	40	17	31	WN..0604..	0,700		
212046400	212349600	S25T PWLN R/L 08	25	23	11,5	300	40	17	31	WN..0804..	0,700		
212349700	212349800	S32U PWLN R/L 08	32	30	15,0	350	50	22	39	WN..0804..	2,050		
212349900	212350000	S40V PWLN R/L 08	40	37	18,5	400	60	27	48	WN..0804..	3,750		











Stock Items | Itens de stock

Available under request | Disponível sob consulta | Disponible bajo consulta









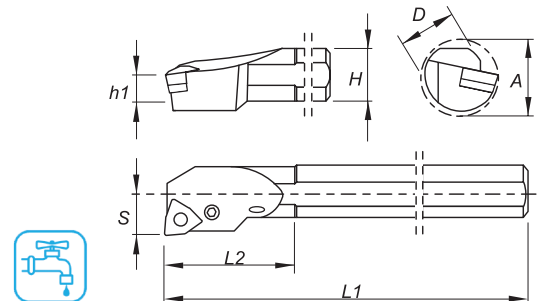
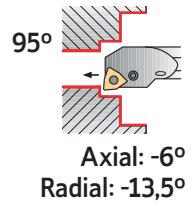





SPARE PARTS || Complementos | Repuestos

Cutter Reference	Order separately					
	Shim	Shim Pin	Shim Pin Punch	Lever	Lever Screw	Wrench
S16R PWLN R/L 06						
S20S PWLN R/L 06	-	-	-	AN09500	PA0501200	SS20
S25T PWLN R/L 06	CW060301	BE04400	BF40009	AN01200	PA0601700	SS25
S25T PWLN R/L 08	-	-	-	AC13200	PA0801700	SS30
S32U PWLN R/L 08	CW080300	BE05500	BF47509	AN13100	PA0802100	SS30
S40V PWLN R/L 08	CW080300	BE05500	BF47509	AN13100	PA0802100	SS30

(P) LEVER LOCK TOOLHOLDERS

Roughing	Finishing	Medium to Finishing	Medium to Finishing	Medium	Medium
Flat  (06-08)	MF  (06-08)	SF  (06-08)	LC  (08)	MS  (06-08)	PM  (08)
Medium	Medium	Medium Wiper	Roughing to Medium	Roughing	
MR  (06-08)	ST  (08)	MW  (06-08)	SS  (06-08)	HR  (08)	









Order Code		Reference	Dimensions (mm)							Insert	Kg	Stock	
R	L		D	H	h1	L1	L2	S	A			R	L
212350100	212350200	A16M PWLN R/L 06	16	15	7,5	150	24	11	20	WN..0604..	0,200		
212350300	212350400	A20Q PWLN R/L 06	20	18	9,0	180	36	13	27	WN..0604..	0,400		
212350500	212350600	A25R PWLN R/L 06	25	23	11,5	200	40	17	31	WN..0604..	0,700		
212350700	212350800	A32S PWLN R/L 06	32	30	15,0	250	50	22	39	WN..0604..	1,400		
212350900	212351000	A25R PWLN R/L 08	40	37	11,5	200	40	17	31	WN..0804..	0,700		
212351300	212351400	A32S PWLN R/L 08	32	30	15,0	250	50	22	39	WN..0804..	1,400		
212351100	212351200	A40T PWLN R/L 08	40	37	18,5	300	60	27	48	WN..0804..	2,650		

 Stock Items | Itens de stock

 Available under request | Disponivel sob consulta | Disponible bajo consulta

SPARE PARTS || Complementos | Repuestos

Cutter Reference	Order separately					
	Shim	Shim Pin	Shim Pin Punch	Lever	Lever Screw	Wrench
A16M PWLN R/L 06						
A20Q PWLN R/L 06	-	-	-	AN09500	PA0501200	SS20
A25R PWLN R/L 06	-	-	-	AN09500	PA0501200	SS20
A25R PWLN R/L 06	CW060301	BE04400	BF40009	AN01200	PA0601700	SS25
A32S PWLN R/L 06	CW060301	BE04400	BF40009	AN01200	PA0601700	SS25
A25R PWLN R/L 08	-	-	-	AC13200	PA0801700	SS30
A32S PWLN R/L 08	CW080300	BE05500	BF47509	AN13100	PA0802100	SS30
A40T PWLN R/L 08	CW080300	BE05500	BF47509	AN13100	PA0802100	SS30





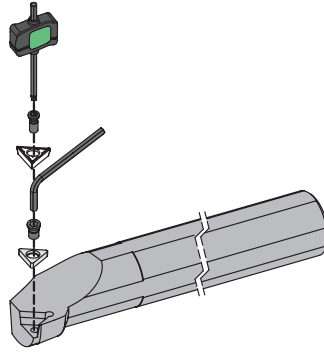







C
TURNING
Insert selection
Overview
Negative inserts
Positive inserts
PCBN & PCD inserts
Heavy turning
External Toolholders
Internal Toolholders
Spare Parts
Technical Data

(S) CENTER SCREW SYSTEM



SCLC 95° PAGE C - 645 CC.. 0602.. CC.. 09T3.. CC.. 1204..	A-SCLC 95° PAGE C - 646 CC.. 0602.. CC.. 09T3.. CC.. 1204..	E-SCLC 95° PAGE C - 647 CC.. 0602.. CC.. 09T3..	SCLCN 95° PAGE C - 648 CC.. 0602.. CC.. 09T3.. CC.. 1204..		
SDQC 107°30' PAGE C - 649 DC.. 0702.. DC.. 11T3..	A-SDQC 107°30' PAGE C - 650 DC.. 0702.. DC.. 11T3..				
SDUC 93° PAGE C - 651 DC.. 0702.. DC.. 11T3..	A-SDUC 93° PAGE C - 652 DC.. 0702.. DC.. 11T3..	E-SDUC 93° PAGE C - 653 DC.. 0702..	SDUC 93° - BT PAGE C - 654 DC.. 0702.. DC.. 11T3..	A-SDUC 93° - BT PAGE C - 655 DC.. 0702.. DC.. 11T3..	
SSKC 75° PAGE C - 656 SC..09T3.. SC.. 1204..	A-SSKC 45° PAGE C - 657 SC.. 09T3..	STFC 90° PAGE C - 658 TC.. 0902.. TC.. 1102.. TC.. 16T3..	A-STFC 90° PAGE C - 659 TC.. 0902.. TC.. 1102.. TC.. 16T3..	E-STFC 90° PAGE C - 660 TC.. 0902.. TC.. 1102..	
STUC 93° PAGE C - 661 TC.. 1102.. TC.. 16T3..	SVQC 107°30' PAGE C - 662 VC.. 1103.. VC.. 1604..	A-SVQC 107°30' PAGE C - 663 VC.. 1103.. VC.. 1604..	SVUB 93° PAGE C - 664 VB.. 1604..	SVUC 93° PAGE C - 665 VC.. 1103.. VC.. 1604..	A-SVUC 93° PAGE C - 666 VC.. 1103.. VC.. 1604..
A-SVJC 93° PAGE C - 667 VC.. 1103.. VC.. 1604..					

(S) CENTER SCREW TOOLHOLDERS

Finishing	Finishing	Finishing	Finishing	Finishing	Finishing wiper	Medium to Finishing
Flat  (06-09-12)	FP  (06-09-12)	BO  (06-09-12)	FM  (06-09-12)	FK  (06-09-12)	FW  (06-09)	LM  (06-09-12)
Medium	Medium	Medium	Medium to Finishing wiper	Finishing to Fine finishing	Medium to Finishing	
MP  (06-09-12)	MM  (06-09-12)	MK  (06-09-12)	MW  (06-09-12)	FS  (06-09)	LN  (06-09-12)	

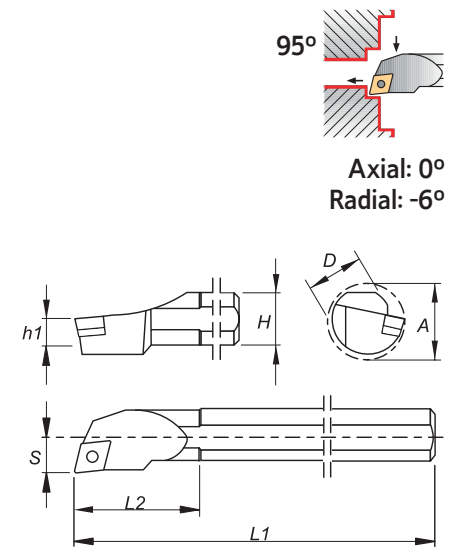

Order Code		Reference	Dimensions (mm)							Insert	Kg	Stock	
R	L		D	H	h1	L1	L2	S	A			R	L
212046700	212141400	S08K SCLC R/L 06	8	7	3,5	125	16	5	11	CC.. 0602..	0,040	⊗	⊗
212039800	212141500	S10M SCLC R/L 06	10	9	4,5	150	25	7	13	CC.. 0602..	0,060	⊗	⊗
212047300	212141600	S12M SCLC R/L 06	12	11	5,5	150	25	9	16	CC.. 0602..	0,150	⊗	⊗
212079200	212141700	S12M SCLC R/L 09	12	11	5,5	150	25	9	16	CC.. 09T3..	0,150	⊗	⊗
212315200	212315300	S12Q SCLC R/L 09	12	11	5,5	180	25	9	16	CC.. 09T3..	0,150	⊗	⊗
212041600	212044200	S16R SCLC R/L 09	16	15	7,5	200	30	11	20	CC.. 09T3..	0,300	⊗	⊗
212141900	212141800	S20S SCLC R/L 09	20	18	9,0	250	35	13	24	CC.. 09T3..	0,550	⊗	⊗
212142100	212142000	S25T SCLC R7L 09	25	23	11,5	300	40	17	31	CC.. 09T3..	0,550	⊗	⊗
212047400	212142200	S20S SCLC R/L 12	20	18	9,0	250	35	13	24	CC.. 1204..	0,550	⊗	⊗
212045500	212142300	S25T SCLC R/L 12	25	23	11,5	300	40	17	31	CC.. 1204..	0,700	⊗	⊗
212142500	212142400	S32U SCLC R/L 12	32	30	15,0	350	50	22	39	CC.. 1204..	2,050	○	○
212142700	212142600	S40V SCLC R/L 12	40	37	18,5	400	60	27	48	CC.. 1204..	3,750	○	○
212142900	212142800	S50W SCLC R/L 12	50	47	23,5	450	65	35	61	CC.. 1204..	6,500	○	○

⊗ Stock Items | Itens de stock

○ Available under request | Disponível sob consulta | Disponible bajo consulta

SPARE PARTS || Complementos | Repuestos

Cutter Reference	Shim	Shim S crew	Screw	Wrench
S08K SCLC R/L 06	-	-	P0200601	XT07
S10M SCLC R/L 06	-	-	P0200601	XT07
S12M SCLC R/L 06	-	-	P0200601	XT07
S12M SCLC R/L 09	-	-	P0400802	XT15-S35
S12Q SCLC R/L 09	-	-	P0400802	XT15-S35
S16R SCLC R/L 09	-	-	P0400802	XT15-S35
S20S SCLC R/L 09	-	-	P0400802	XT15-S35
S25T SCLC R7L 09	-	-	P0400802	XT15-S35
S20S SCLC R/L 12	-	-	P0501200	XT15-S40
S25T SCLC R/L 12	-	-	P0501200	XT15-S40
S32U SCLC R/L 12	CC120401	T06004000	P0401400	XT15-S40
S40V SCLC R/L 12	CC120401	T06004000	P0401400	XT15-S40
S50W SCLC R/L 12	CC120401	T06004000	P0401400	XT15-S40

TURNING
Insert selection
Overview
Negative inserts
Positive inserts
PCBN & PCD inserts
Heavy turning
External Toolholders
Internal Toolholders
Automatic Lathes
Spare Parts
Technical Data

(S) CENTER SCREW TOOLHOLDERS

Finishing	Finishing	Finishing	Finishing	Finishing	Finishing wiper	Medium to Finishing
Flat  (06-09-12)	FP  (06-09-12)	BO  (06-09-12)	FM  (06-09-12)	FK  (06-09-12)	FW  (06-09)	LM  (06-09-12)
Medium	Medium	Medium	Medium to Finishing wiper	Finishing to Fine finishing	Medium to Finishing	
MP  (06-09-12)	MM  (06-09-12)	MK  (06-09-12)	MW  (06-09-12)	FS  (06-09)	LN  (06-09-12)	

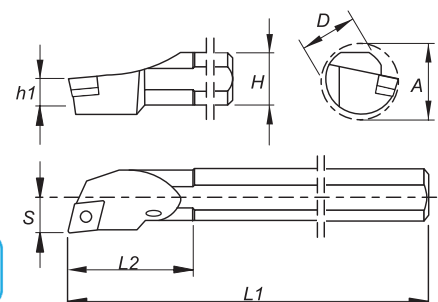
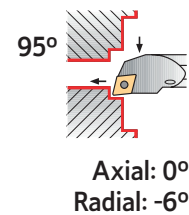

Order Code		Reference	Dimensions (mm)							Insert	Kg	Stock	
R	L		D	H	h1	L1	L2	S	A			R	L
212315400	212315500	A08F SCLC R/L 06	8	7	3,5	80	16	5	11	CC.. 0602..	0,030		
212315600	212315700	A10H SCLC R/L 06	10	9	4,5	100	25	7	13	CC.. 0602..	0,040		
212315800	212315900	A12K SCLC R/L 06	12	11	5,5	125	25	9	16	CC.. 0602..	0,100		
212316000	212316100	A16M SCLC R/L 09	16	15	7,5	150	30	11	20	CC.. 09T3..	0,200		
212316200	212316300	A20Q SCLC R/L 09	20	18	9,0	180	35	13	24	CC.. 09T3..	0,400		
212316400	212316500	A25R SCLC R/L 09	25	23	11,5	200	40	17	31	CC.. 09T3..	0,700		
212316600	212316700	A32S SCLC R/L 12	32	30	15,0	250	50	22	39	CC.. 1204..	1,400		
212316800	212316900	A40T SCLC R/L 12	40	37	18,5	300	60	27	48	CC.. 1204..	2,650		













Stock Itens | Itens de stock

Available under request | Disponível sob consulta | Disponible bajo consulta







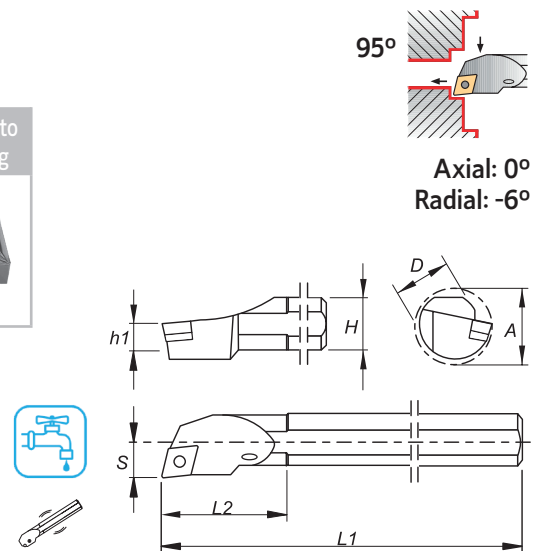

SPARE PARTS || Complementos | Repuestos

Cutter Reference	Shim	Shim S crew	Screw	Wrench
A08F SCLC R/L 06	-	-	P0200601	XT07
A10H SCLC R/L 06	-	-	P0200601	XT07
A12K SCLC R/L 06	-	-	P0200601	XT07
A16M SCLC R/L 09	-	-	P0400802	XT15-S35
A20Q SCLC R/L 09	-	-	P0400802	XT15-S35
A25R SCLC R/L 09	-	-	P0400802	XT15-S35
A32S SCLC R/L 12	CC120401	T06004000	P0401400	XT15-S40
A40T SCLC R/L 12	CC120401	T06004000	P0401400	XT15-S40

(S) CENTER SCREW TOOLHOLDERS

Finishing	Finishing	Finishing	Finishing	Finishing	Finishing wiper	Medium to Finishing
Flat  (06-09)	FP  (06-09)	BO  (06-09)	FM  (06-09)	FK  (06-09)	FW  (06-09)	LM  (06-09)
Medium	Medium	Medium	Medium to Finishing wiper	Finishing to Fine finishing	Medium to Finishing	
MP  (06-09)	MM  (06-09)	MK  (06-09)	MW  (06-09)	FS  (06-09)	LN  (06-09)	



Order Code		Reference	Dimensions (mm)							Insert	Kg	Stock	
R	L		D	H	h1	L1	L2	S	A			R	L
212317800	212317900	E08K SCLC R/L 06	8	7	3,5	125	16	5	11	CC.. 0602..	0,080		
212318000	212318100	E10M SCLC R/L 06	10	9	4,5	150	25	7	13	CC.. 0602..	0,150		
212317400	212318300	E12Q SCLC R/L 06	12	11	5,5	180	25	9	16	CC.. 0602..	0,250		
212318400	212317600	E16R SCLC R/L 09	16	15	7,5	200	30	11	20	CC.. 09T3..	0,600		











 Stock items | Itens de stock

 Available under request | Disponível sob consulta | Disponible bajo consulta

SPARE PARTS | Complementos | Repuestos

Cutter Reference	Screw	Wrench
		
E08K SCLC R/L 06	P0200601	XT07
E10M SCLC R/L 06	P0200601	XT07
E12M SCLC R/L 06	P0200601	XT07
E16R SCLC R/L 09	P0400802	XT15-S35

(S) CENTER SCREW TOOLHOLDERS

Finishing	Finishing	Finishing	Finishing	Finishing	Finishing wiper	Medium to Finishing
Flat  (06-09-12)	FP  (06-09-12)	BO  (06-09-12)	FM  (06-09-12)	FK  (06-09-12)	FW  (06-09)	LM  (06-09-12)
Medium	Medium	Medium	Medium to Finishing wiper	Finishing to Fine finishing	Medium to Finishing	
MP  (06-09-12)	MM  (06-09-12)	MK  (06-09-12)	MW  (06-09-12)	FS  (06-09)	LN  (06-09-12)	

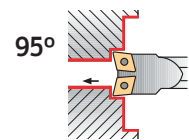

Axial: 0°
Radial: -9°

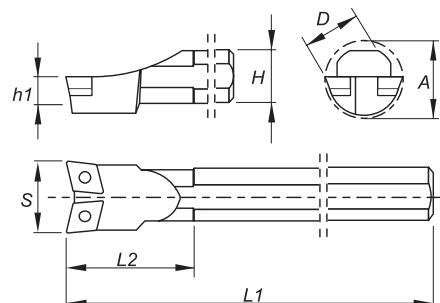





Order Code	Reference	Dimensions (mm)							Insert	Kg	Stock
		D	H	h1	L1	L2	S	A			
212143000	S12M SCLC N 06	12	11	5,5	150	25	18	20	CC.. 0602..	0,150	⊗
212143100	S16R SCLC N 06	16	15	7,5	200	30	22	25	CC.. 0602..	0,300	⊗
212143200	S20S SCLC N 06	20	18	9,0	250	35	26	30	CC.. 0602..	0,550	⊗
212143300	S25T SCLC N 09	25	23	11,5	300	40	34	40	CC.. 09T3..	0,700	⊗
212143400	S32U SCLC N 12	32	30	15,0	350	50	44	50	CC.. 1204..	2,050	○
212143500	S40V SCLC N 12	40	37	18,5	400	60	54	60	CC.. 1204..	3,750	○
212143600	S50W SCLC N 12	50	47	23,5	450	65	62	68	CC.. 1204..	6,500	○









⊗ Stock Items | Itens de stock

○ Available under request | Disponível sob consulta | Disponible bajo consulta



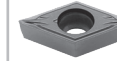



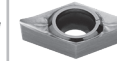

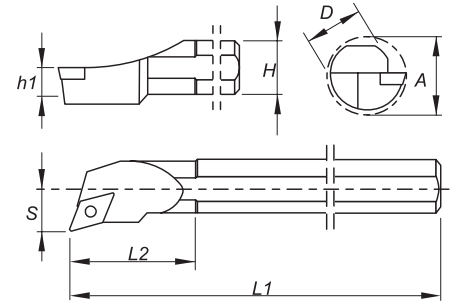
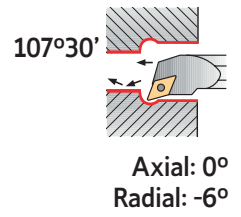







SPARE PARTS || Complementos | Repuestos

Cutter Reference	Shim 	Shim Screw 	Screw 	Wrench 
S12M SCLC N 06	-	-	P0200601	XT07
S16R SCLC N 06	-	-	P0200601	XT07
S20S SCLC N 06	-	-	P0200601	XT07
S25T SCLC N 09	-	-	P0400802	XT15-S35
S32U SCLC N 12	CC120401	T06004000	P0401400	XT15-S40
S40V SCLC N 12	CC120401	T06004000	P0401400	XT15-S40
S50W SCLC N 12	CC120401	T06004000	P0401400	XT15-S40

(S) CENTER SCREW TOOLHOLDERS

Finishing	Finishing	Finishing	Finishing	Medium to Finishing
Flat	FP	FM	FK	LM
 (07-11)	 (07-11)	 (07-11)	 (07-11)	 (07-11)
Medium	Medium	Medium	Finishing to Fine Finishing	Finishing to Fine Finishing
MP	MM	MK	FS	LN
 (07-11)	 (07-11)	 (07-11)	 (07-11)	 (07-11)







Order Code		Reference	Dimensions (mm)							Insert	Kg	Stock	
R	L		D	H	h1	L1	L2	S	A			R	L
212147000	212146900	S10M SDQC R/L 07	10	9	4,5	150	25	7	13	DC.. 0702..	0,060		
212147200	212147100	S12M SDQC R/L 07	12	11	5,5	150	25	9	16	DC.. 0702..	0,150		
212147400	212147300	S16R SDQC R/L 07	16	15	7,5	200	30	11	20	DC.. 0702..	0,300		
212147600	212147500	S20S SDQC R/L 07	20	18	9,0	250	35	13	24	DC.. 0702..	0,550		
212147800	212147700	S20S SDQC R/L 11	20	18	9,0	250	35	13	24	DC.. 11T3..	0,550		
212148000	212147900	S25T SDQC R/L 11	25	23	11,5	300	40	17	31	DC.. 11T3..	0,700		
212148100	212148200	S32U SDQC R/L 11	32	30	15,0	350	50	22	39	DC.. 11T3..	2,050		
212148300	212148400	S40V SDQC R/L 11	40	37	18,5	400	60	27	48	DC.. 11T3..	3,750		

 Stock Items | Itens de stock











 Available under request | Disponível sob consulta | Disponible bajo consulta

SPARE PARTS | Complementos | Repuestos

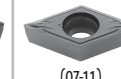
Cutter Reference	Shim	Shim Screw	Screw	Wrench
				
S10M SDQC R/L 07	-	-	P0200601	XT07
S12M SDQC R/L 07	-	-	P0250700	XT07
S16R SDQC R/L 07	-	-	P0250700	XT07
S20S SDQC R/L 07	-	-	P0250700	XT07
S20S SDQC R/L 11	-	-	P0401100	XT15-S35
S25T SDQC R/L 11	-	-	P0401100	XT15-S35
S32U SDQC R/L 11	CD110301	T05003500	P0351500	XT15-S35
S40V SDQC R/L 11	CD110301	T05003500	P0351500	XT15-S35

C
TURNING
Insert selection
Overview
Negative inserts
Positive inserts
PCBN & PCD inserts
Heavy turning
External Toolholders
Internal Toolholders
Automatic Lathes
Spare Parts
Technical Data





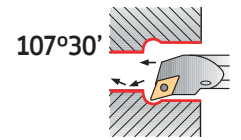



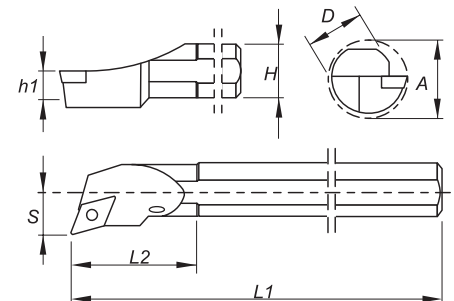



(S) CENTER SCREW TOOLHOLDERS

Finishing	Finishing	Finishing	Finishing	Medium to Finishing
Flat  (07-11)	FP  (07-11)	FM  (07-11)	FK  (07-11)	LM  (07-11)
Medium	Medium	Medium	Finishing to Fine Finishing	Finishing to Fine Finishing
MP  (07-11)	MM  (07-11)	MK  (07-11)	FS  (07-11)	LN  (07-11)



Axial: 0°
Radial: -6°







Order Code		Reference	Dimensions (mm)							Insert	Kg	Stock	
R	L		D	H	h1	L1	L2	S	A			R	L
212318600	212318700	A12K SDQC R/L 07	12	11	5,5	125	25	9	16	DC.. 0702..	0,100		
212318800	212318900	A16M SDQC R/L 07	16	15	7,5	150	30	11	20	DC.. 0702..	0,200		
212319000	212319100	A20Q SDQC R/L 11	20	18	9,0	180	35	13	24	DC.. 11T3..	0,400		
212319200	212319300	A25R SDQC R/L 11	25	23	11,5	200	40	17	31	DC.. 11T3..	0,700		
212319400	212319500	A32S SDQC R/L 11	32	30	15,0	250	50	22	39	DC.. 11T3..	1,400		
212319600	212319700	A40T SDQC R/L 11	40	37	18,5	300	60	27	48	DC.. 11T3..	2,650		







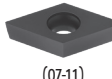

 Stock Items | Itens de stock

 Available under request | Disponível sob consulta | Disponible bajo consulta



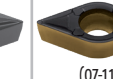
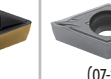



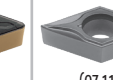
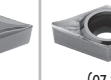

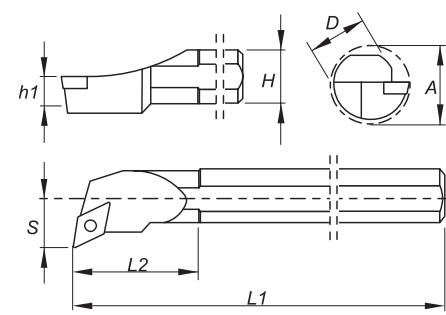
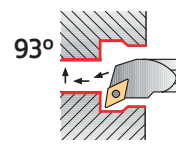









SPARE PARTS | Complementos | Repuestos

Cutter Reference	Shim	Shim Screw	Screw	Wrench
A12K SDQC R/L 07				
A16M SDQC R/L 07	-	-	P0250700	XT07
A20Q SDQC R/L 11	-	-	P0401100	XT15-S35
A25R SDQC R/L 11	-	-	P0401100	XT15-S35
A32S SDQC R/L 11	CD110301	T05003500	P0351500	XT15-S35
A40T SDQC R/L 11	CD110301	T05003500	P0351500	XT15-S35

(S) CENTER SCREW TOOLHOLDERS

Finishing	Finishing	Finishing	Finishing	Finishing wiper	Medium to Finishing
Flat	FP	FM	FK	FW	LM
 (07-11)	 (07-11)	 (07-11)	 (07-11)	 (07-11)	 (07-11)
Medium	Medium	Medium	Medium to Finishing wiper	Finishing to Fine Finishing	Finishing to Fine Finishing
MP	MM	MK	MW	FS	LN
 (07-11)	 (07-11)	 (07-11)	 (11)	 (07-11)	 (07-11)







Order Code		Reference	Dimensions (mm)							Insert	Kg	Stock	
R	L		D	H	h1	L1	L2	S	A			R	L
212144700	212144600	S10M SDUC R/L 07	10	9	4,5	150	25	7	13	DC.. 0702..	0,060		
212028500	212028600	S12M SDUC R/L 07	12	11	5,5	150	25	9	16	DC.. 0702..	0,150		
212319800	212319900	S12Q SDUC R/L 07	12	11	5,5	180	25	9	16	DC.. 0702..	0,150		
212028700	212028800	S16R SDUC R/L 07	16	15	7,5	200	30	11	20	DC.. 0702..	0,300		
212144900	212144800	S20S SDUC R/L 07	20	18	9,0	250	35	13	24	DC.. 0702..	0,550		
212036800	212028900	S20S SDUC R/L 11	20	18	9,0	250	35	13	24	DC.. 11T3..	0,550		
212029000	212038400	S25T SDUC R/L 11	25	23	11,5	300	40	17	31	DC.. 11T3..	0,700		
212145200	212145100	S32U SDUC R/L 11	32	30	15,0	350	50	22	39	DC.. 11T3..	2,050		
212145400	212145300	S40V SDUC R/L 11	40	37	18,5	400	60	27	48	DC.. 11T3..	3,750		

 Stock items | Itens de stock

 Available under request | Disponível sob consulta | Disponible bajo consulta

SPARE PARTS | Complementos | Repuestos







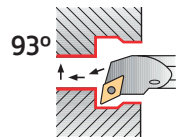

Cutter Reference	Shim	Shim Screw	Screw	Wrench
S10M SDUC R/L 07				
S12M SDUC R/L 07	-	-	P0200601	XT07
S12Q SDUC R/L 07	-	-	P0250700	XT07
S16R SDUC R/L 07	-	-	P0250700	XT07
S20S SDUC R/L 07	-	-	P0250700	XT07
S20S SDUC R/L 11	-	-	P0401100	XT15-S35
S25T SDUC R/L 11	-	-	P0401100	XT15-S35
S32U SDUC R/L 11	CD110301	T05003500	P0351500	XT15-S40
S40V SDUC R/L 11	CD110301	T05003500	P0351500	XT15-S40

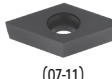
C
 TURNING
 Insert selection
 Overview
 Negative inserts
 Positive inserts
 PCBN & PCD inserts
 Heavy turning
 External Toolholders
 Internal Toolholders
 Automatic Lathes
 Spare Parts
 Technical Data



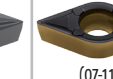
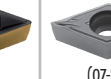



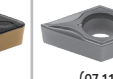
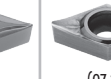

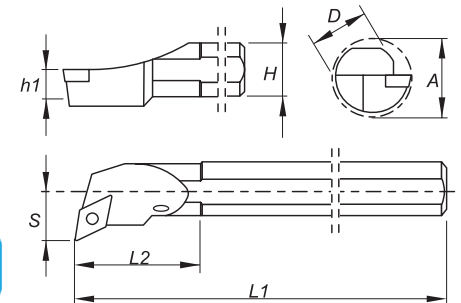



(S) CENTER SCREW TOOLHOLDERS



Axial: 0°
Radial: -6°

Finishing	Finishing	Finishing	Finishing	Finishing wiper	Medium to Finishing
Flat	FP	FM	FK	FW	LM
 (07-11)	 (07-11)	 (07-11)	 (07-11)	 (07-11)	 (07-11)
Medium	Medium	Medium	Medium to Finishing wiper	Finishing to Fine Finishing	Finishing to Fine Finishing
MP	MM	MK	MW	FS	LN
 (07-11)	 (07-11)	 (07-11)	 (11)	 (07-11)	 (07-11)







Order Code		Reference	Dimensions (mm)							Insert	Kg	Stock	
R	L		D	H	h1	L1	L2	S	A			R	L
212320000	212320100	A12K SDUC R/L 07	12	11	5,5	125	25	9	16	DC.. 0702..	0,100		
212320200	212320300	A16M SDUC R/L 07	16	15	7,5	150	30	11	20	DC.. 0702..	0,200		
212320400	212320500	A20Q SDUC R/L 11	20	18	9,0	180	35	13	24	DC.. 11T3..	0,400		
212320600	212320700	A25R SDUC R/L 11	25	23	11,5	200	40	17	31	DC.. 11T3..	0,700		
212320800	212320900	A32S SDUC R/L 11	32	30	15,0	250	50	22	39	DC.. 11T3..	1,400		
212321000	212321100	A40T SDUC R/L 11	40	37	18,5	300	60	27	48	DC.. 11T3..	2,650		







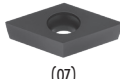
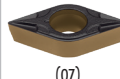

 Stock Items | Itens de stock

 Available under request | Disponível sob consulta | Disponible bajo consulta



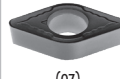

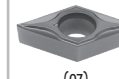

SPARE PARTS | Complementos | Repuestos

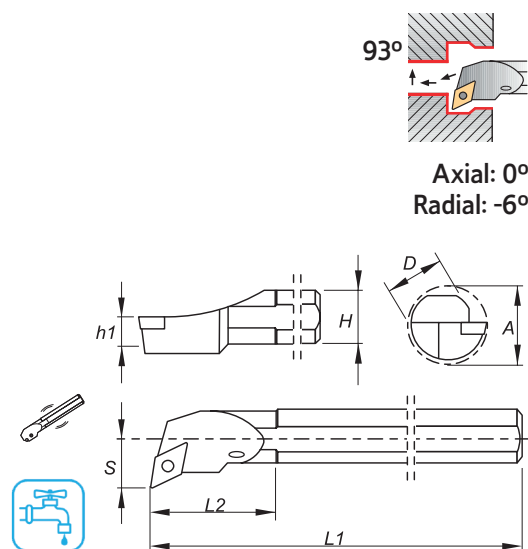
Cutter Reference	Shim	Shim Screw	Screw	Wrench
A12K SDUC R/L 07				
A16M SDUC R/L 07	-	-	P0250700	XT07
A20Q SDUC R/L 11	-	-	P0401100	XT15-S35
A25R SDUC R/L 11	-	-	P0401100	XT15-S35
A32S SDUC R/L 11	CD110301	T05003500	P0351500	XT15-S35
A40T SDUC R/L 11	CD110301	T05003500	P0351500	XT15-S35

(S) CENTER SCREW TOOLHOLDERS

Finishing	Finishing	Finishing	Finishing	Finishing wiper
Flat	FP	FM	FK	FW
 (07)	 (07)	 (07)	 (07)	 (07)
Medium	Medium	Medium	Finishing to Fine Finishing	Finishing to Fine Finishing
MP	MM	MK	FS	LN
 (07)	 (07)	 (07)	 (07)	 (07)



Order Code		Reference	Dimensions (mm)							Insert	Kg	Stock	
R	L		D	H	h1	L1	L2	S	A			R	L
212321800	212321300	E10M SDUC R/L 07	10	9	4,5	150	25	7	13	DC.. 0702..	0,150		
212322000	212322100	E12Q SDUC R/L 07	12	11	5,5	180	25	9	16	DC.. 0702..	0,250		
212322200	212321700	E16R SDUC R/L 07	16	15	7,5	200	30	11	20	DC.. 0702..	0,600		







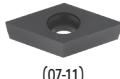
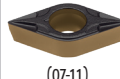

 Stock Items | Itens de stock

 Available under request | Disponível sob consulta | Disponible bajo consulta

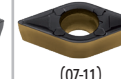
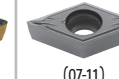
SPARE PARTS || Complementos | Repuestos

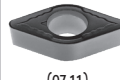
Cutter Reference	Screw	Wrench
		
E10M SDUC R/L 07	P0200601	XT07
E12M SDUC R/L 07	P0250700	XT07
E16R SDUC R/L 07	P0250700	XT07

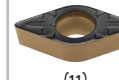
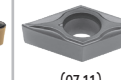



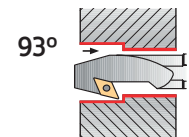



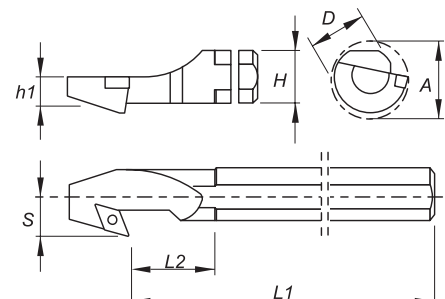





(S) CENTER SCREW TOOLHOLDERS

Finishing	Finishing	Finishing	Finishing	Finishing wiper	Medium to Finishing
Flat	FP	FM	FK	FW	LM
 (07-11)	 (07-11)	 (07-11)	 (07-11)	 (07-11)	 (07-11)
Medium	Medium	Medium	Medium to Finishing wiper	Finishing to Fine Finishing	Finishing to Fine Finishing
MP	MM	MK	MW	FS	LN
 (07-11)	 (07-11)	 (07-11)	 (11)	 (07-11)	 (07-11)



Axial: 0°
Radial: -6°







Order Code		Reference	Dimensions (mm)							Insert	Kg	Stock	
R	L		D	H	h1	L1	L2	S	A			R	L
212145600	212145500	S12M SDUC R/L 07-BT	12	11	5,5	150	25	9	16	DC.. 0702..	0,150		
212145800	212145700	S16R SDUC R/L 07-BT	16	15	7,5	200	30	11	20	DC.. 0702..	0,300		
212146000	212145900	S20S SDUC R/L 07-BT	20	18	9,0	250	35	13	24	DC.. 0702..	0,550		
212146200	212146100	S20S SDUC R/L 11-BT	20	18	9,0	250	35	13	24	DC.. 11T3..	0,550		
212146400	212146300	S25T SDUC R/L 11-BT	25	23	11,5	300	40	17	31	DC.. 11T3..	0,700		
212146600	212146500	S32U SDUC R/L 11-BT	32	30	15,0	350	50	22	39	DC.. 11T3..	2,050		
212146800	212146700	S40V SDUC R/L 11-BT	40	37	18,5	400	60	27	48	DC.. 11T3..	3,750		







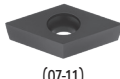
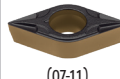

 Stock Items | Itens de stock

 Available under request | Disponível sob consulta | Disponible bajo consulta

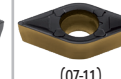
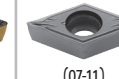

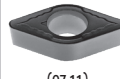

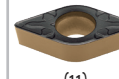
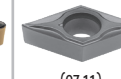

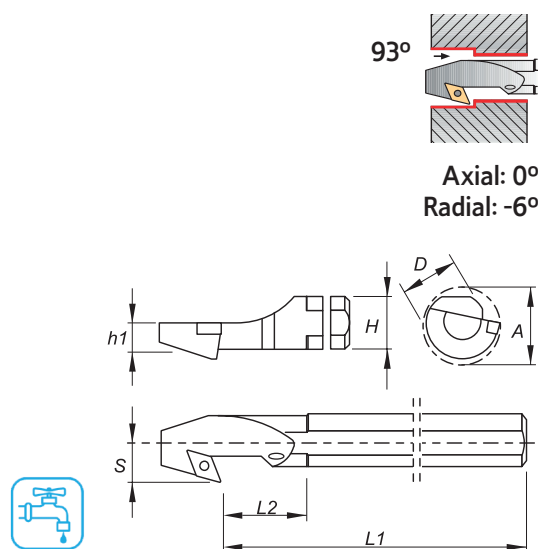

SPARE PARTS || Complementos | Repuestos

Cutter Reference	Shim	Shim Screw	Screw	Wrench
S12M SDUC R/L 07-BT				
S16R SDUC R/L 07-BT	-	-	P0250700	XT07
S20S SDUC R/L 07-BT	-	-	P0250700	XT07
S20S SDUC R/L 11-BT	-	-	P0400802	XT15-S35
S25T SDUC R/L 11-BT	-	-	P0401100	XT15-S35
S32U SDUC R/L 11-BT	CD110301	T05003500	P0351500	XT15-S35
S40V SDUC R/L 11-BT	CD110301	T05003500	P0351500	XT15-S35

(S) CENTER SCREW TOOLHOLDERS

Finishing	Finishing	Finishing	Finishing	Finishing wiper	Medium to Finishing
Flat	FP	FM	FK	FW	LM
 (07-11)	 (07-11)	 (07-11)	 (07-11)	 (07-11)	 (07-11)
Medium	Medium	Medium	Medium to Finishing wiper	Finishing to Fine Finishing	Finishing to Fine Finishing
MP	MM	MK	MW	FS	LN
 (07-11)	 (07-11)	 (07-11)	 (11)	 (07-11)	 (07-11)



Order Code		Reference	Dimensions (mm)							Insert	Kg	Stock	
R	L		D	H	h1	L1	L2	S	A			R	L
212322400	212322500	A12K SDUC R/L 07-BT	12	11	5,5	125	25	9	16	DC.. 0702..	0,100		
212322600	212322700	A16M SDUC R/L 07-BT	16	15	7,5	150	30	11	20	DC.. 0702..	0,200		
212322800	212322900	A20Q SDUC R7L 11-BT	20	18	9,0	180	35	13	24	DC.. 11T3..	0,400		
212323000	212323100	A25R SDUC R/L 11-BT	25	23	11,5	200	40	17	31	DC.. 11T3..	0,700		

 Stock Items | Itens de stock

 Available under request | Disponível sob consulta | Disponible bajo consulta

SPARE PARTS || Complementos | Repuestos





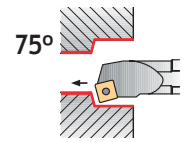

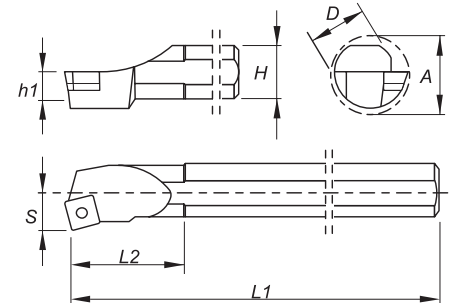

Cutter Reference	Screw	Wrench
		
A12K SDUC R/L 07-BT	P0250700	XT07
A16M SDUC R/L 07-BT	P0250700	XT07
A20Q SDUC R7L 11-BT	P0400802	XT15-S35
A25R SDUC R/L 11-BT	P0401100	XT15-S35













(S) CENTER SCREW TOOLHOLDERS



Axial: 0°
Radial: -8°



Finishing	Finishing	Finishing	Finishing
Flat  (09-12)	FP  (09)	FM  (09)	FK  (09)
Medium	Medium	Medium	Medium to Finishing
MP  (09-12)	MM  (09-12)	MK  (09-12)	LN  (09-12)

Order Code		Reference	Dimensions (mm)							Insert	Kg	Stock	
R	L		D	H	h1	L1	L2	S	A			R	L
212150400	212150300	S16R SSKC R/L 09	16	15	7,5	200	30	11	20	SC.. 09T3..	0,300		
212150600	212150500	S20S SSKC R/L 09	20	18	9,0	250	35	13	24	SC.. 09T3..	0,550		
212045800	212150700	S25T SSKC R/L 09	25	23	11,5	300	40	17	31	SC.. 09T3..	0,700		
212045900	212150800	S32U SSKC R/L 12	32	30	15,0	350	50	22	39	SC.. 1204..	2,050		
212151000	212150900	S40V SSKC R/L 12	40	37	18,5	400	60	27	48	SC.. 1204..	3,750		
212151200	212151100	S50W SSKC R/L 12	50	47	23,5	450	65	35	61	SC.. 1204..	6,500		









 Stock Items | Itens de stock

 Available under request | Disponível sob consulta | Disponible bajo consulta

SPARE PARTS || Complementos | Repuestos

Cutter Reference	Shim 	Shim Screw 	Screw 	Wrench 
S16R SSKC R/L 09	-	-	P0400802	XT15-S35
S20S SSKC R/L 09	-	-	P0400802	XT15-S35
S25T SSKC R/L 09	-	-	P0400802	XT15-S35
S32U SSKC R/L 12	CC120400	T06004000	P0401400	XT15-S40
S40V SSKC R/L 12	CC120400	T06004000	P0401400	XT15-S40
S50W SSKC R/L 12	CC120400	T06004000	P0401400	XT15-S40





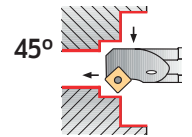

(S) CENTER SCREW TOOLHOLDERS

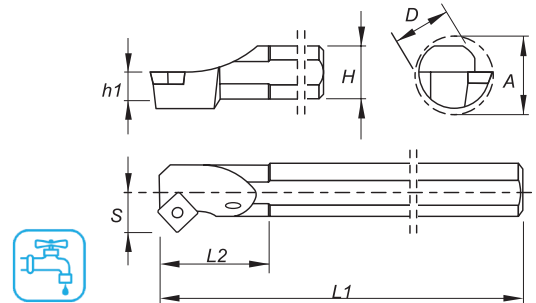
Finishing	Finishing	Finishing	Finishing
Flat	FP	FM	FK
 (09)	 (09)	 (09)	 (09)
Medium	Medium	Medium	Medium to Finishing
MP	MM	MK	LN
 (09)	 (09)	 (09)	 (09)



Axial: 0°
Radial: -8°



Order Code		Reference	Dimensions (mm)							Insert	Kg	Stock	
R	L		D	H	h1	L1	L2	S	A			R	L
212323200	212323300	A16M SSSC R/L 09	16	15	7,5	150	30	11	20	SC.. 09T3..	0,300		
212323400	212323500	A20Q SSSC R/L 09	20	18	9,0	180	35	13	24	SC.. 09T3..	0,550		
212323600	212323700	A25R SSSC R/L 09	25	23	11,5	200	40	17	31	SC.. 09T3..	0,700		

 Stock Items | Itens de stock

 Available under request | Disponível sob consulta | Disponible bajo consulta

SPARE PARTS || Complementos | Repuestos





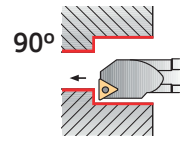

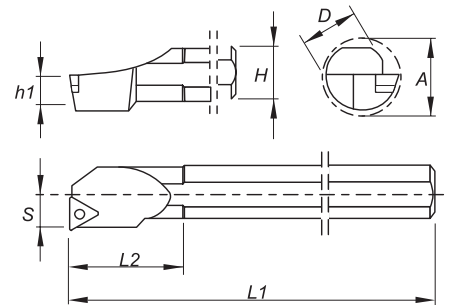

Cutter Reference	Screw	Wrench
		
A16M SSSC R/L 09	P0400802	XT15-S35
A20Q SSSC R/L 09	P0400802	XT15-S35
A25R SSSC R/L 09	P0400802	XT15-S35





















(S) CENTER SCREW TOOLHOLDERS



Axial: 0°
Radial: -6°







Finishing	Finishing	Finishing	Finishing
Flat  (09-11-16)	FP  (09-11-16)	FM  (09-11-16)	FK  (09-11-16)
Medium	Medium	Medium	Medium to Finishing
MP  (09-11-16)	MM  (09-11-16)	MK  (09-11-16)	LN  (11-16)

Order Code		Reference	Dimensions (mm)							Insert	Kg	Stock	
R	L		D	H	h1	L1	L2	S	A			R	L
212159500	212159400	S10M STFC R/L 09	10	9	4,5	150	25	7	13	TC.. 0902..	0,060		
212159700	212159600	S12M STFC R/L 09	12	11	5,5	150	25	9	16	TC.. 0902..	0,150		
212039500	212159800	S12M STFC R/L 11	12	11	5,5	150	25	9	16	TC.. 1102..	0,150		
212323800	212323900	S12Q STFC R/L 11	12	11	5,5	180	25	9	16	TC.. 1102..	0,050		
212160000	212159900	S16R STFC R/L 11	16	15	7,5	200	30	11	20	TC.. 1102..	0,300		
212021000	212160100	S20S STFC R/L 11	20	18	9,0	250	35	13	24	TC.. 1102..	0,550		
212250700	212324000	S20S STFC R/L 16	20	18	9,0	250	35	13	24	TC.. 16T3..	0,550		
212160300	212160200	S25T STFC R/L 16	25	23	11,5	300	40	17	31	TC.. 16T3..	0,700		
212160500	212160400	S32U STFC R/L 16	32	30	15,0	350	50	22	39	TC.. 16T3..	2,050		
212160700	212160600	S40V STFC R/L 16	40	37	18,5	400	60	27	48	TC.. 16T3..	3,750		









 Stock Items | Itens de stock

 Available under request | Disponível sob consulta | Disponible bajo consulta









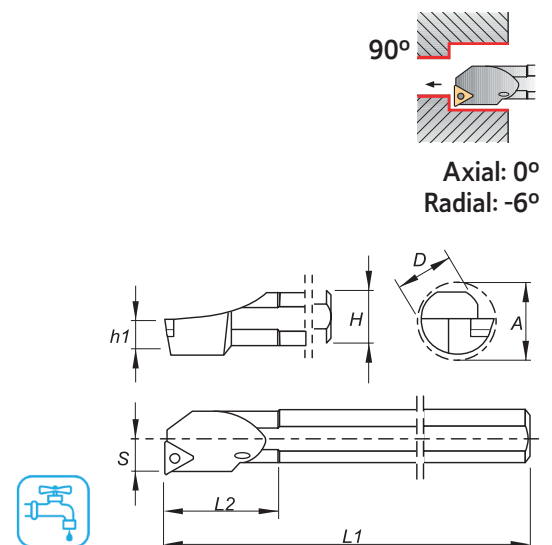





SPARE PARTS || Complementos | Repuestos

Cutter Reference	Shim	Shim Screw	Screw	Wrench
S10M STFC R/L 09				
S12M STFC R/L 09	-	-	P0220600	XT06
S12M STFC R/L 11	-	-	P0250700	XT07
S12Q STFC R/L 11	-	-	P0250700	XT07
S16R STFC R/L 11	-	-	P0250700	XT07
S20S STFC R/L 11	-	-	P0250700	XT07
S20S STFC R/L 16	-	-	P0401100	XT15-S35
S25T STFC R/L 16	-	-	P0401100	XT15-S35
S32U STFC R/L 16	CT160302	T05003500	P0351500	XT15-S35
S40V STFC R/L 16	CT160302	T05003500	P0351500	XT15-S35

(S) CENTER SCREW TOOLHOLDERS

Finishing	Finishing	Finishing	Finishing
Flat	FP	FM	FK
 (09-11-16)	 (09-11-16)	 (09-11-16)	 (09-11-16)
Medium	Medium	Medium	Medium to Finishing
MP	MM	MK	LN
 (09-11-16)	 (09-11-16)	 (09-11-16)	 (11-16)







Order Code		Reference	Dimensions (mm)							Insert	Kg	Stock	
R	L		D	H	h1	L1	L2	S	A			R	L
212324100	212324200	A10H STFC R/L 09	10	9	4,5	100	25	7	13	TC.. 0902..	0,040		
212324300	212324400	A12K STFC R/L 11	12	11	5,5	125	25	9	16	TC.. 1102..	0,100		
212324500	212324600	A16M STFC R/L 11	16	15	7,5	150	30	11	20	TC.. 1102..	0,200		
212324700	212324800	A20Q STFC R/L 11	20	18	9,0	180	35	13	24	TC.. 1102..	0,400		
212324900	212325000	A25R STFC R/L 16	25	23	11,5	200	40	17	31	TC.. 16T3..	0,700		
212325100	212325200	A32S STFC R/L 16	32	30	15,0	250	50	22	39	TC.. 16T3..	1,400		
212325300	212325400	A40T STFC R/L 16	40	37	18,5	300	60	27	48	TC.. 16T3..	2,650		

 Stock Items | Itens de stock

 Available under request | Disponível sob consulta | Disponible bajo consulta

SPARE PARTS | Complementos | Repuestos

Cutter Reference	Shim	Shim Screw	Screw	Wrench
A10H STFC R/L 09				
A12K STFC R/L 11	-	-	P0220600	XT06
A16M STFC R/L 11	-	-	P0250700	XT07
A20Q STFC R/L 11	-	-	P0250700	XT07
A25R STFC R/L 16	-	-	P0401100	XT15-S35
A32S STFC R/L 16	CT160302	T05003500	P0351500	XT15-S35
A40T STFC R/L 16	CT160302	T05003500	P0351500	XT15-S35





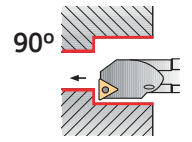

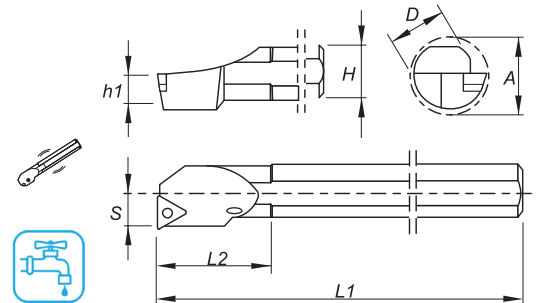

C
TURNING
Insert selection
Overview
Negative inserts
Positive inserts
PCBN & PCD inserts
Heavy turning
External Toolholders
Internal Toolholders
Automatic Lathes
Spare Parts
Technical Data





(S) CENTER SCREW TOOLHOLDERS



Axial: 0°
Radial: -6°





Finishing	Finishing	Finishing	Finishing
Flat	FP	FM	FK
 (09-11)	 (09-11)	 (09-11)	 (09-11)
Medium	Medium	Medium	Medium to Finishing
MP	MM	MK	LN
 (09-11)	 (09-11)	 (09-11)	 (11)

Order Code		Reference	Dimensions (mm)							Insert	Kg	Stock	
R	L		D	H	h1	L1	L2	S	A			R	L
212326200	212326300	E12Q STFC R/L 11	12	11	5,5	180	25	9	16	TC.. 1102..	0,250		
212326400	212326500	E16R STFC R/L 11	16	15	7,5	200	30	11	20	TC.. 1102..	0,600		









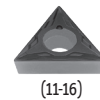

 Stock Items | Itens de stock

 Available under request | Disponível sob consulta | Disponible bajo consulta









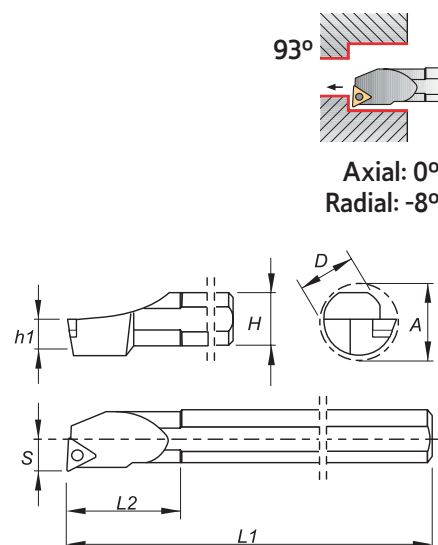

SPARE PARTS || Complementos | Repuestos

Cutter Reference	Screw	Wrench
E12M STFC R/L 11	 P0250700	 XT07
E16R STFC R/L 11	P0400802	XT15-S35

(S) CENTER SCREW TOOLHOLDERS

Finishing	Finishing	Finishing	Finishing	Finishing wiper
Flat  (11-16)	FP  (11-16)	FM  (11-16)	FK  (11-16)	FW  (11-16)
Medium	Medium	Medium	Medium to Finishing wiper	Medium to Finishing
MP  (11-16)	MM  (11-16)	MK  (11-16)	MW  (11-16)	LN  (11-16)







Order Code		Reference	Dimensions (mm)							Insert	Kg	Stock	
R	L		D	H	h1	L1	L2	S	A			R	L
212029100	212029200	S12M STUC R/L 11	12	11	5,5	150	25	9	16	TC.. 1102..	0,150		
212029300	212029400	S16R STUC R/L 16	16	15	7,5	200	30	11	20	TC.. 16T3..	0,300		
212036900	212029500	S20S STUC R/L 16	20	18	9,0	250	35	13	24	TC.. 16T3..	0,550		
212029600	212029700	S25T STUC R/L 16	25	23	11,5	300	40	17	31	TC.. 16T3..	0,700		
212160800	212044600	S32U STUC R/L 16	32	30	15,0	350	50	22	39	TC.. 16T3..	2,050		

 Stock Items | Itens de stock

 Available under request | Disponível sob consulta | Disponible bajo consulta







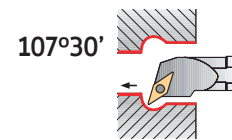

SPARE PARTS | Complementos | Repuestos

Cutter Reference	Shim 	Shim Screw 	Screw 	Wrench 
S12M STUC R/L 11	-	-	P0250700	XT07
S16R STUC R/L 16	-	-	P0401100	XT15-S35
S20S STUC R/L 16	-	-	P0401100	XT15-S35
S25T STUC R/L 16	-	-	P0401100	XT15-S35
S32U STUC R/L 16	CT160302	T05003500	P0351500	XT15-S35









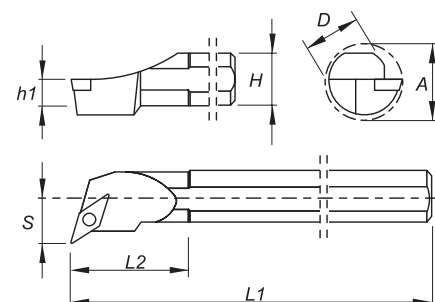

(S) CENTER SCREW TOOLHOLDERS



Axial: 0°
Radial: -6°

Finishing	Finishing	Finishing	Finishing
Flat	FP	FM	FK
			
(11-16)	(11-16)	(11-16)	(11-16)
Medium	Medium	Medium	Medium to Finishing
MP	MM	MK	LN
			
(11-16)	(11-16)	(11-16)	(11-16)







Order Code		Reference	Dimensions (mm)							Insert	Kg	Stock	
R	L		D	H	h1	L1	L2	S	A			R	L
212165000	212165100	S16R SVQC R/L 11	16	15	7,5	200	30	11	20	VC.. 1103..	0,300		
212165200	212165300	S20S SVQC R/L 11	20	18	9,0	250	35	13	24	VC.. 1103..	0,550		
212165500	212165400	S16R SVQC R/L 13	16	15	7,5	200	30	13	22	VC.. 1103..	0,300		
212165700	212165600	S20S SVQC R/L 13	20	18	9,0	250	35	13	24	VC.. 1103..	0,550		
212165900	212165800	S25T SVQC R/L 16	25	23	11,5	300	40	17	31	VC.. 1604..	0,700		







 Stock Items | Itens de stock

 Available under request | Disponível sob consulta | Disponible bajo consulta

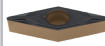
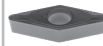

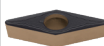

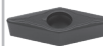



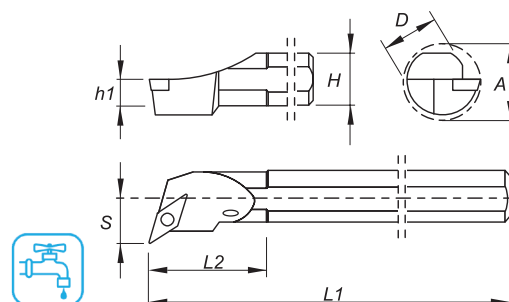
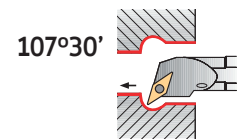

SPARE PARTS || Complementos | Repuestos

Cutter Reference	Shim	Shim Screw	Screw	Wrench
S16R SVQC R/L 11				
S20S SVQC R/L 11	-	-	P0250700	XT07
S16R SVQC R/L 13	-	-	P0300900	XT08
S20S SVQC R/L 13	-	-	P0300900	XT08
S25T SVQC R/L 16	CV160300	T05003500	P0351500	XT15-S35

(S) CENTER SCREW TOOLHOLDERS

Finishing	Finishing	Finishing	Finishing
Flat	FP	FM	FK
			
(11-16)	(11-16)	(11-16)	(11-16)
Medium	Medium	Medium	Medium to Finishing
MP	MM	MK	LN
			
(11-16)	(11-16)	(11-16)	(11-16)







Order Code		Reference	Dimensions (mm)							Insert	Kg	Stock	
R	L		D	H	h1	L1	L2	S	A			R	L
212326600	212326700	A16M SVQC R/L 11	16	15	7,5	150	30	11	20	VC.. 1103..	0,200		
212326800	212326900	A20Q SVQC R/L 11	20	18	9,0	180	35	13	24	VC.. 1103..	0,400		
212327000	212327100	A25R SVQC R/L 16	25	23	11,5	200	40	17	31	VC.. 1604..	0,700		
212327200	212327300	A32S SVQC R/L 16	32	30	15,0	250	50	22	39	VC.. 1604..	1,400		
212327400	212327500	A40T SVQC R/L 16	40	37	18,5	300	60	27	48	VC.. 1604..	2,650		

 Stock Items | Itens de stock

 Available under request | Disponível sob consulta | Disponible bajo consulta





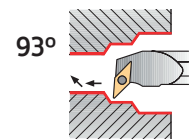

SPARE PARTS || Complementos | Repuestos

Cutter Reference	Shim	Shim Screw	Screw	Wrench
A16M SVQC R/L 11				
A20Q SVQC R/L 11	-	-	P0250700	XT07
A25R SVQC R/L 16	CV160300	T05003500	P0351500	XT15-S35
A32S SVQC R/L 16	CV160300	T05003500	P0351500	XT15-S35
A40T SVQC R/L 16	CV160300	T05003500	P0351500	XT15-S35







(S) CENTER SCREW TOOLHOLDERS

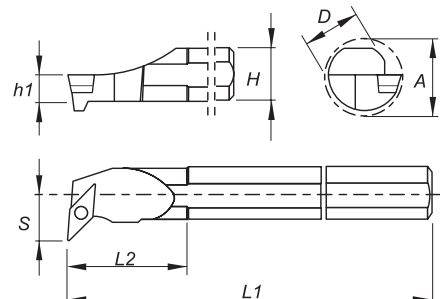

Axial: 0°
Radial: -5°

Finishing	Finishing	Finishing	Finishing
Flat	FP	FM	FK
			
(16)	(16)	(16)	(16)
Medium	Medium	Medium	
MP	MM	MK	
			
(16)	(16)	(16)	





Order Code		Reference	Dimensions (mm)							Insert	Kg	Stock	
R	L		D	H	h1	L1	L2	S	A			R	L
212056200	212327600	S25T SVUB R/L 16	25	23	11,5	300	40	17	31	VB.. 1604..	0,700		
212327700	212327800	S32U SVUB R/L 16	32	30	15,0	350	50	22	39	VB.. 1604..	2,050		
212327900	212328000	S40V SVUB R/L 16	40	37	18,5	400	60	27	48	VB.. 1604..	3,750		







 Stock Items | Itens de stock

 Available under request | Disponível sob consulta | Disponible bajo consulta

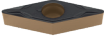







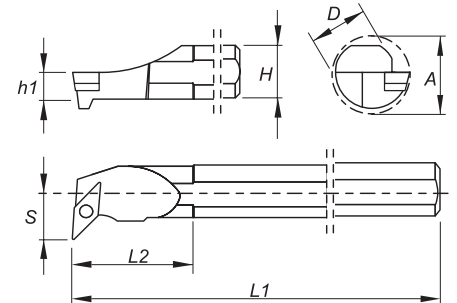
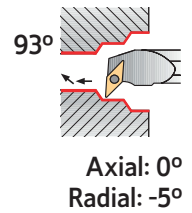

SPARE PARTS | Complementos | Repuestos

Cutter Reference	Shim	Shim Screw	Screw	Wrench
S25T SVUB R/L 16				
S32U SVUB R/L 16	CV160300	T05003500	P0351500	XT15-S35
S40V SVUB R/L 16	CV160300	T05003500	P0351500	XT15-S35

(S) CENTER SCREW TOOLHOLDERS

Finishing	Finishing	Finishing	Finishing
Flat	FP	FM	FK
			
(11-16)	(11-16)	(11-16)	(11-16)
Medium	Medium	Medium	Medium to Finishing
MP	MM	MK	LN
			
(11-16)	(11-16)	(11-16)	(11-16)







Order Code		Reference	Dimensions (mm)							Insert	Kg	Stock	
R	L		D	H	h1	L1	L2	S	A			R	L
212166000	212166100	S16R SVUC R/L 11	16	15	7,5	200	30	11	20	VC.. 1103..	0,300		
212166200	212166300	S20S SVUC R/L 11	20	18	9,0	250	35	13	24	VC.. 1103..	0,550		
212328100	212166400	S25T SVUC R/L 16	25	23	11,5	300	40	17	31	VC.. 1604..	0,700		
212328200	212166500	S32U SVUC R/L 16	32	30	15,0	350	50	22	39	VC.. 1604..	2,050		
212166700	212166600	S40V SVUC R/L 16	40	37	18,5	400	60	27	48	VC.. 1604..	3,750		

 Stock Items | Itens de stock

 Available under request | Disponível sob consulta | Disponible bajo consulta







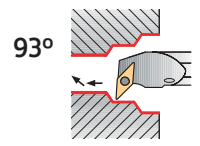

SPARE PARTS || Complementos | Repuestos

Cutter Reference	Shim	Shim Screw	Screw	Wrench
S16R SVUC R/L 11				
S20S SVUC R/L 11	-	-	P0250700	XT07
S25T SVUC R/L 16	CV160300	T05003500	P0351500	XT15-S35
S32U SVUC R/L 16	CV160300	T05003500	P0351500	XT15-S35
S40V SVUC R/L 16	CV160300	T05003500	P0351500	XT15-S35









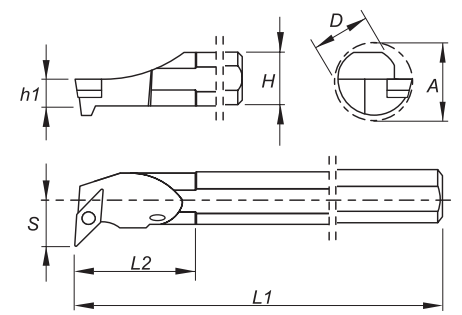

(S) CENTER SCREW TOOLHOLDERS



Axial: 0°
Radial: -5°

Finishing	Finishing	Finishing	Finishing
Flat	FP	FM	FK
 (11-16)	 (11-16)	 (11-16)	 (11-16)
Medium	Medium	Medium	Medium to Finishing
MP	MM	MK	LN
 (11-16)	 (11-16)	 (11-16)	 (11-16)







Order Code		Reference	Dimensions (mm)							Insert	Kg	Stock	
R	L		D	H	h1	L1	L2	S	A			R	L
212328300	212328400	A16M SVUC R/L 11	16	15	7,5	150	30	11	20	VC.. 1103..	0,200		
212328500	212328600	A20Q SVUC R/L 11	20	18	9,0	180	35	13	24	VC.. 1103..	0,400		
212328700	212328800	A25R SVUC R/L 16	25	23	11,5	200	40	17	31	VC.. 1604..	0,700		
212328900	212329000	A32S SVUC R/L 16	32	30	15,0	250	50	22	39	VC.. 1604..	1,400		
212329100	212329200	A40T SVUC R/L 16	40	37	18,5	300	60	27	48	VC.. 1604..	2,650		







 Stock Items | Itens de stock

Available under request | Disponível sob consulta | Disponible bajo consulta

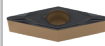
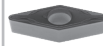
SPARE PARTS | Complementos | Repuestos

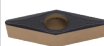
Cutter Reference	Shim	Shim Screw	Screw	Wrench
A16M SVUC R/L 11				
A20Q SVUC R/L 11	-	-	P0250700	XT07
A25R SVUC R/L 16	CV160300	T05003500	P0351500	XT15-S35
A32S SVUC R/L 16	CV160300	T05003500	P0351500	XT15-S35
A40T SVUC R/L 16	CV160300	T05003500	P0351500	XT15-S35

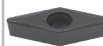
(S) CENTER SCREW TOOLHOLDERS





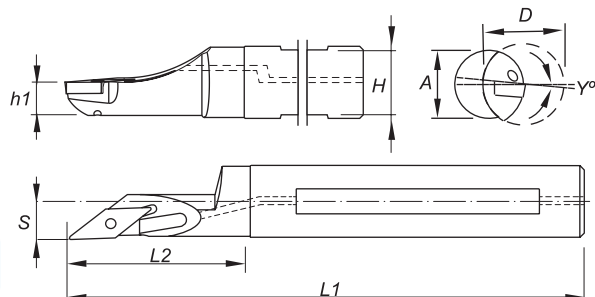

Finishing	Finishing	Finishing	Finishing
Flat	FP	FM	FK
			
(11-16)	(11-16)	(11-16)	(11-16)
Medium	Medium	Medium	Medium to Finishing
MP	MM	MK	LN
			
(11-16)	(11-16)	(11-16)	(11-16)

35°



Axial: 0°
Radial: -6°



Order Code		Reference	Dimensions (mm)								Insert	Kg	Stock	
R	L		D	H	h1	L1	L2	S	Y°	A			R	L
212362400	212362500	A16M SVJC R/L 11	16	15	7,5	150	30	8,5	22	22	VC.. 1103..	0,200		
212362600	212362700	A20Q SVJC R/L 11	20	18	9,0	180	35	10,5	25	25	VC.. 1103..	0,300		
212362800	212362900	A25R SVJC R/L 16	25	23	11,5	200	40	13,0	28	28	VC.. 1604..	0,650		

 Stock Items | Itens de stock

 Available under request | Disponível sob consulta | Disponible bajo consulta

SPARE PARTS || Complementos | Repuestos

Cutter Reference	Screw	Wrench
		
A16M SVJC R/L 11	P0250700	XT07
A20Q SVJC R/L 11	P0250700	XT07
A25R SVJC R/L 16	P0401100	XT15-S35

TURNING
Insert selection
Overview
Negative inserts
Positive inserts
PCBN & PCD inserts
Heavy turning
External Toolholders
Internal Toolholders
Automatic Lathes
Spare Parts
Technical Data

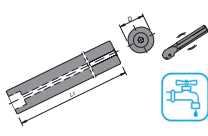
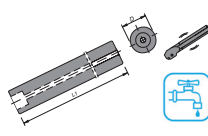
<p>AVB 7xØ</p>  <p>PAGE C - 669</p>	<p>AVB 10xØ</p>  <p>PAGE C - 670</p>
---	---

(D) DIMPLE LOCK ANTI VIBRATION FOR INTERNAL TURNING

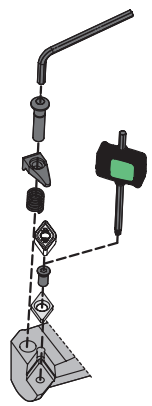

DCLN 85°



PAGE C - 671 CN.. 1204..

(S) CENTER SCREW ANTI VIBRATION FOR INTERNAL TURNING

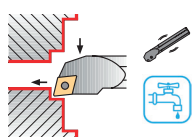
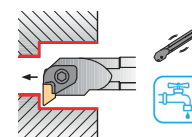
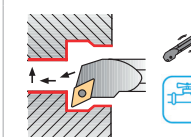
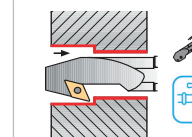
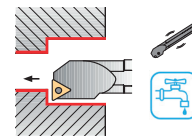
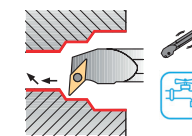

<p>SCLC 85°</p>  <p>PAGE C - 672 CC.. 0602.. CC.. 09T3.. CC.. 1204..</p>	<p>SDNC 62°30'</p>  <p>PAGE C - 673 DC.. 0702.. DC.. 11T3..</p>	<p>SDUC 87°</p>  <p>PAGE C - 674 DC.. 0702.. DC.. 11T3..</p>	<p>SDXC 93°</p>  <p>PAGE C - 675 DC.. 0702.. DC.. 11T3..</p>
<p>STFC 89°</p>  <p>PAGE C - 676 TC.. 1102.. TC.. 16T3..</p>	<p>SVUB 87°</p>  <p>PAGE C - 677 VB.. 1102.. VB.. 1604..</p>		

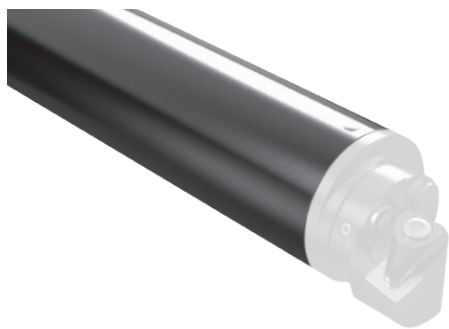

* Maximum depth of cut: 7x Diameter

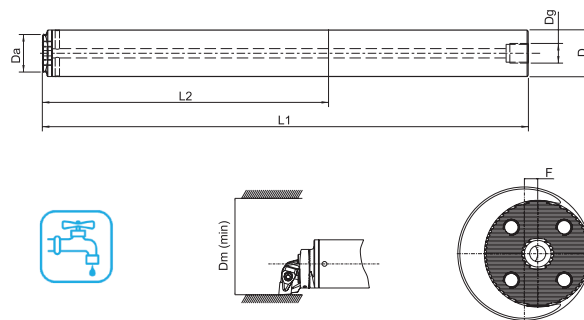

Order Code	Reference	Dimensions (mm)							Stock
		ØD	ØDa	Dm(min)	F	L1	L2	ØDg	
212454800	AVB16-16-7D	16	16	20	-	156	92	G1/8"	⊗
212454900	AVB20-20-7D	20	20	25	-	200	120	G1/4"	⊗
212455000	AVB25-25-7D	25	25	32	-	255	155	G1/4"	⊗
212455100	AVB32-32-7D	32	32	40	-	320	192	G3/8"	⊗
212455200	AVB40-40-7D	40	40	50	-	408	248	G1/2"	○
212455300	AVB50-40-7D	50	40	60	5	518	318	G1/2"	○
212455400	AVB60-40-7D	60	40	72	10	628	388	G3/4"	○

⊗ Stock Items | Itens de stock

○ Available under request | Disponível sob consulta | Disponible bajo consulta

Note: The toolholder is supplied without the cutting head.

SPARE PARTS || Complementos | Repuestos

Reference	Screw	Wrench
AVB16-16-7D	D0301101	SS25
AVB20-20-7D	D0301101	SS25
AVB25-25-7D	D0401200	SS25
AVB32-32-7D	D0501200	SS30
AVB40-40-7D	D0601600	SS40
AVB50-40-7D	D0602200	SS50
AVB60-40-7D	D0602200	SS50

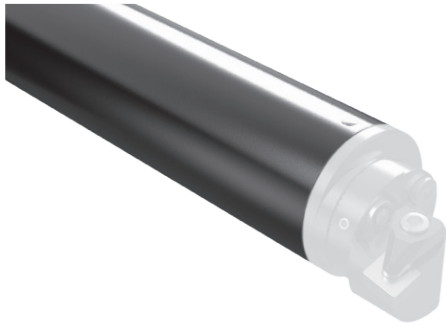

* Maximum depth of cut: 10x Diameter

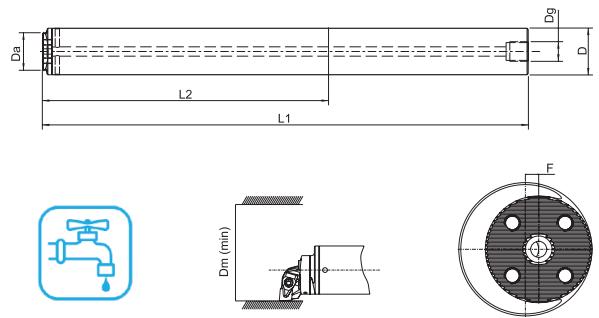

Order Code	Reference	Dimensions (mm)							Stock
		ØD	ØDa	ØDm(min)	F	L1	L2	ØDg	
212455500	AVB25-25-10D	25	25	32	-	330	230	G1/4"	⊗
212455600	AVB32-32-10D	32	32	40	-	416	288	G3/8"	⊗
212455700	AVB40-40-10D	40	40	50	-	528	368	G1/2"	○
212455800	AVB50-40-10D	50	40	60	5	668	468	G1/2"	○
212455900	AVB60-40-10D	60	40	72	10	808	568	G3/4"	○

⊗ Stock Items | Itens de stock

○ Available under request | Disponível sob consulta | Disponible bajo consulta

Note: The toolholder is supplied without the cutting head.

SPARE PARTS | Complementos | Repuestos

Reference	Screw	Wrench
AVB25-25-10D	D0401200	SS25
AVB32-32-10D	D0501200	SS30
AVB40-40-10D	D0601600	SS40
AVB50-40-10D	D0602200	SS50
AVB60-40-10D	D0602200	SS50

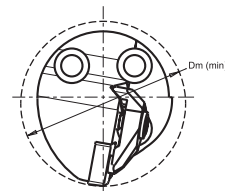
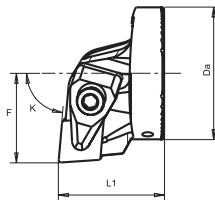







L	R	Reference	Dimensions (mm)						Stock	
			ØDa	ØDm	F	L1	L2	Insert	L	R
212459100	212456000	AVH32 DCLN R/L-12	32	40	22	38	-	CN.. 1204	○	⊗
212459200	212456100	AVH40 DCLN R/L-12	40	50	27	38	-	CN.. 1204	○	○

⊗ Stock Items | Itens de stock

○ Available under request | Disponível sob consulta | Disponible bajo consulta

SPARE PARTS || Complementos | Repuestos

Reference	Shim	Shim Screw	Spring	Clamp	Clamp Screw	Wrench
AVH32 DCLN R/L-12						
AVH40 DCLN R/L-12	CC120300	T06010000	M09513	GA07002	D0602900	SS40

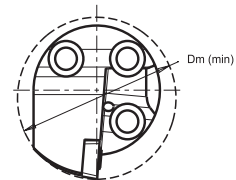
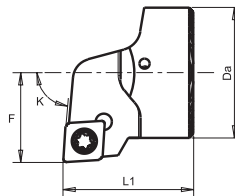

L	R	Reference	Dimensions (mm)						Stock	
			ØDa	ØDm	F	L1	L2	Insert	L	R
212459300	212456200	AVH16 SCLC R/L-06	16	20	11	20	-	CC.. 0602	⊗	⊗
212459400	212456300	AVH20 SCLC R/L-09	20	25	13	20	-	CC.. 09T3	⊗	⊗
212459500	212456400	AVH25 SCLC R/L-09	25	32	17	20	-	CC.. 09T3	⊗	⊗
212459600	212456500	AVH32 SCLC R/L-09	32	40	22	32	-	CC.. 09T3	⊗	⊗
212459700	212456600	AVH40 SCLC R/L-12	40	50	27	38	-	CC.. 1204	○	○

⊗ Stock Items | Itens de stock

○ Available under request | Disponível sob consulta | Disponible bajo consulta

SPARE PARTS || Complementos | Repuestos

Reference	Shim	Shim Screw	Screw	Wrench
AVH16 SCLC R/L-06	-	-	P0250700	XT07
AVH20 SCLC R/L-09	-	-	P0401100	XT15-S35
AVH25 SCLC R/L-09	-	-	P0401100	XT15-S35
AVH32 SCLC R/L-09	-	-	P0401100	XT15-S35
AVH40 SCLC R/L-12	CC120401	T06004000	P0401400	XT15-S40

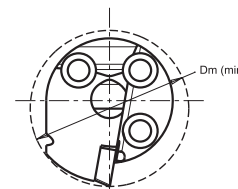
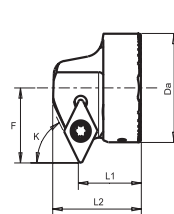
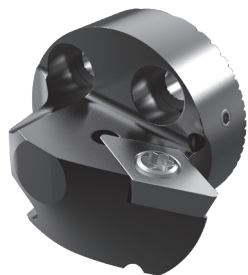

L	R	Reference	Dimensions (mm)						Stock	
			ØDa	ØDm	F	L1	L2	Insert	L	R
212460800	212457700	AVH16 SDNC R/L-07	16	22	13	15	19,5	DC.. 0702		
212460900	212457800	AVH20 SDNC R/L-07	20	27	15	15	19,5	DC.. 0702		
212461000	212457900	AVH25 SDNC R/L-07	25	33	18	15	19,5	DC.. 0702		
212461100	212458000	AVH32 SDNC R/L-11	32	40	22	20	28	DC.. 11T3		
212461200	212458100	AVH40 SDNC R/L-11	40	50	27	20	28	DC.. 11T3		

Stock Items | Itens de stock

Available under request | Disponível sob consulta | Disponible bajo consulta

SPARE PARTS || Complementos | Repuestos

Reference	Shim	Shim Screw	Screw	Wrench
AVH16 SDNC R/L-07				
AVH16 SDNC R/L-07	-	-	P0250700	XT07
AVH20 SDNC R/L-07	-	-	P0250700	XT07
AVH25 SDNC R/L-07	-	-	P0250700	XT07
AVH32 SDNC R/L-11	CD110301	T05003500	P0351500	XT15-S35
AVH40 SDNC R/L-11	CD110301	T05003500	P0351500	XT15-S35

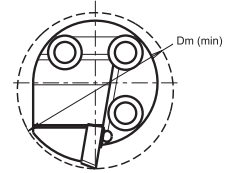
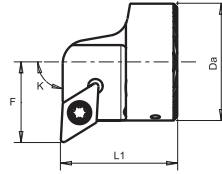

L	R	Reference	Dimensions (mm)						Stock	
			ØDa	ØDm	F	L1	L2	Insert	L	R
212459800	212456700	AVH16 SDUC R/L-07	16	20	11	20	-	DC.. 0702		
212459900	212456800	AVH20 SDUC R/L-07	20	25	13	20	-	DC.. 0702		
212460000	212456900	AVH25 SDUC R/L-11	25	32	17	20	-	DC.. 11T3		
212460100	212457000	AVH32 SDUC R/L-11	32	40	22	32	-	DC.. 11T3		
212460200	212457100	AVH40 SDUC R/L-11	40	50	27	32	-	DC.. 11T3		

Stock Items | Itens de stock

Available under request | Disponível sob consulta | Disponible bajo consulta

SPARE PARTS || Complementos | Repuestos

Reference	Shim	Shim Screw	Screw	Wrench
AVH16 SDUC R/L-07				
AVH16 SDUC R/L-07	-	-	P0250700	XT07
AVH20 SDUC R/L-07	-	-	P0250700	XT07
AVH25 SDUC R/L-11	-	-	P0401100	XT15-S35
AVH32 SDUC R/L-11	CD110301	T05003500	P0351500	XT15-S35
AVH40 SDUC R/L-11	CD110301	T05003500	P0351500	XT15-S35

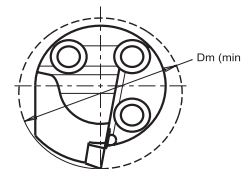
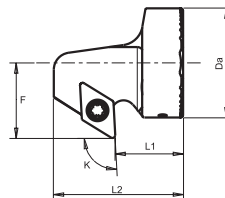

L	R	Reference	Dimensions (mm)						Stock	
			ØDa	ØDm	F	L1	L2	Insert	L	R
212460300	212457200	AVH16 SDXC R/L-07	16	22	13	15	26,5	DC.. 0702		
212460400	212457300	AVH20 SDXC R/L-07	20	27	15	15	26,5	DC.. 0702		
212460500	212457400	AVH25 SDXC R/L-07	25	33	18	15	26,5	DC.. 0702		
212460600	212457500	AVH32 SDXC R/L-11	32	40	22	20	38	DC.. 11T3		
212460700	212457600	AVH40 SDXC R/L-11	40	50	27	20	38	DC.. 11T3		

Stock items | Itens de stock

Available under request | Disponível sob consulta | Disponible bajo consulta

SPARE PARTS || Complementos | Repuestos

Reference	Shim	Shim Screw	Screw	Wrench
AVH16 SDXC R/L-07				
AVH16 SDXC R/L-07	-	-	P0250700	XT07
AVH20 SDXC R/L-07	-	-	P0250700	XT07
AVH25 SDXC R/L-07	-	-	P0250700	XT07
AVH32 SDXC R/L-11	CD110301	T05003500	P0351500	XT15-S35
AVH40 SDXC R/L-11	CD110301	T05003500	P0351500	XT15-S35

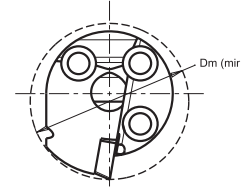
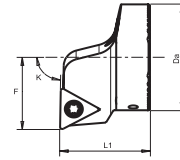





L	R	Reference	Dimensions (mm)						Stock	
			ØDa	ØDm	F	L1	L2	Insert	L	R
212461700	212458600	AVH16 STFC R/L-11	16	20	11	20	-	TC.. 1102	○	⊗
212461800	212458700	AVH20 STFC R/L-11	20	25	13	20	-	TC.. 1102	○	⊗
212461900	212458800	AVH25 STFC R/L-11	25	32	17	20	-	TC.. 1102	○	⊗
212462000	212458900	AVH32 STFC R/L-16	32	40	22	32	-	TC.. 16T3	○	○
212462100	212459000	AVH40 STFC R/L-16	40	50	27	32	-	TC.. 16T3	○	○

⊗ Stock Items | Itens de stock

○ Available under request | Disponível sob consulta | Disponible bajo consulta

SPARE PARTS || Complementos | Repuestos

Reference	Shim	Shim Screw	Screw	Wrench
AVH16 STFC R/L-11				
AVH16 STFC R/L-11	-	-	P0250700	XT07
AVH20 STFC R/L-11	-	-	P0250700	XT07
AVH25 STFC R/L-16	-	-	P0250700	XT07
AVH32 STFC R/L-16	CT160302	T05003500	P0351500	XT15-S35
AVH40 STFC R/L-16	CT160302	T05003500	P0351500	XT15-S35

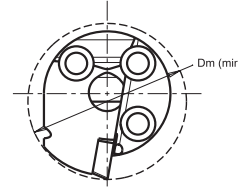
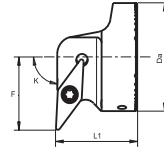
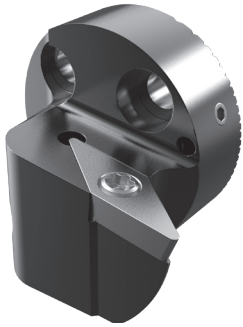





L	R	Reference	Dimensions (mm)						Stock	
			ØDa	ØDm	F	L1	L2	Insert	L	R
212461300	212458200	AVH20 SVUB R/L-11	20	27	16	20	-	VB.. 1102	○	⊗
212461400	212458300	AVH25 SVUB R/L-11	25	31	17	25	-	VB.. 1102	○	⊗
212461500	212458400	AVH32 SVUB R/L-16	32	40	22	32	-	VB.. 1604	○	⊗
212461600	212458500	AVH40 SVUB R/L-16	40	50	27	32	-	VB.. 1604	○	○

⊗ Stock Items | Itens de stock

○ Available under request | Disponível sob consulta | Disponible bajo consulta

SPARE PARTS || Complementos | Repuestos

Reference	Shim	Shim Screw	Screw	Wrench
AVH20 SVUB R/L-11				
AVH25 SVUB R/L-11	-	-	P0250700	XT07
AVH32 SVUB R/L-16	CV160300	T05003500	P0351500	XT15-S35
AVH40 SVUB R/L-16	CV160300	T05003500	P0351500	XT15-S35

Tooling solutions for Wind Energy Industry



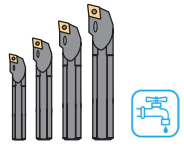
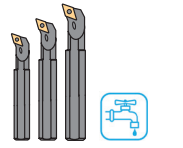
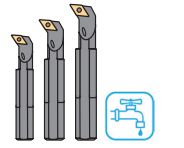
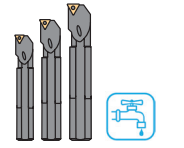









<p>PK SCLC 95°</p>  <p>PAGE C - 680 CC.. 0602..</p>	<p>PK SDQC 107°30'</p>  <p>PAGE C - 681 DC.. 0702..</p>	<p>PK SDUC 93°</p>  <p>PAGE C - 682 DC.. 0702..</p>	<p>PK STFC 90°</p>  <p>PAGE C - 683 TC.. 1102..</p>
---	---	---	--









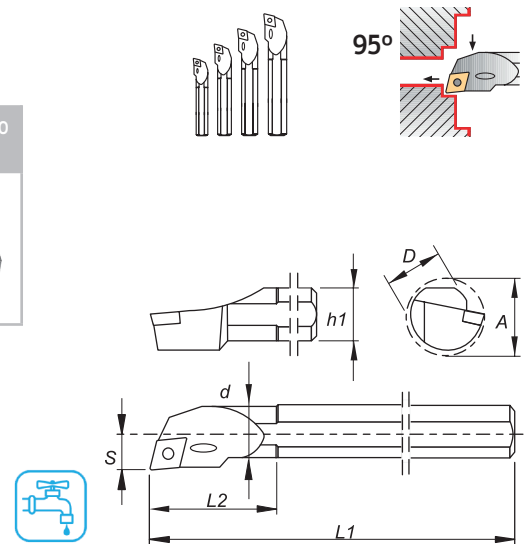



INTERNAL TOOLHOLDERS SET

Conjuntos de ferramentas de torneamento interno | Grupos de herramientas de torneado interno

Finishing	Finishing	Finishing	Finishing	Finishing	Finishing wiper	Medium to Finishing
Flat  (06)	FP  (06)	BO  (06)	FM  (06)	FK  (06)	FW  (06)	LM  (06)
Medium	Medium	Medium	Medium to Finishing wiper	Finishing to Fine finishing	Medium to Finishing	
MP  (06)	MM  (06)	MK  (06)	MW  (06)	FS  (06)	LN  (06)	





Order Code		Reference	Dimensions (mm)							Insert	Kg	Stock	
R Pack	R		D	d	L1	L2	S	A	h1			Pack	R
212359300	212250500	A0608H SCLC R 06	8	6	100	25	4	10	7	CC.. 0602..	0,400		
	212359400	A0810J SCLC R 06	10	8	110	32	6	12	9	CC.. 0602..			
	212250600	A1012K SCLC R 06	12	10	125	38	7	14	11	CC.. 0602..			
	212167900	A1216M SCLC R 06	16	12	150	50	9	18	15	CC.. 0602..			

Order Code		Reference	Dimensions (mm)							Insert	Kg	Stock	
L Pack	L		D	d	L1	L2	S	A	L1			Pack	L
212359500	212359600	A0608H SCLC L 06	8	6	100	25	4	10	7	CC.. 0602..	0,400		
	212359700	A0810J SCLC L 06	10	8	110	32	6	12	9	CC.. 0602..			
	212359800	A1012K SCLC L 06	12	10	125	38	7	14	11	CC.. 0602..			
	212359900	A1216M SCLC L 06	16	12	150	50	9	18	15	CC.. 0602..			

 Stock Items | Itens de stock

 Available under request | Disponível sob consulta | Disponible bajo consulta







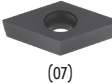
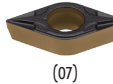

SPARE PARTS || Complementos | Repuestos

Cutter Reference	Screw 	Wrench 
A0608H SCLC R/L 06	P0200601	XT07
A0810J SCLC R/L 06	P0200601	XT07
A1012K SCLC R/L 06	P0250700	XT07
A1216M SCLC R/L 06	P0250700	XT07

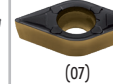
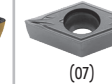

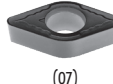

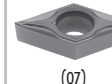
PK SDQC 107°30' || TOOLHOLDERS | Ferros de torno | Herramientas de torneado



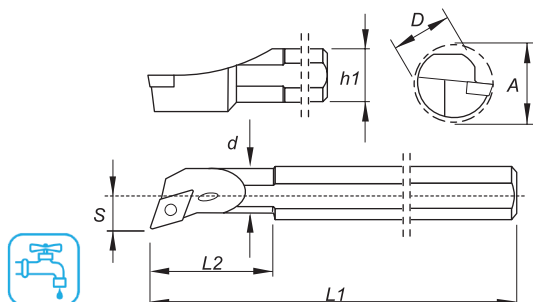
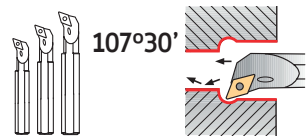

INTERNAL TOOLHOLDERS SET

Conjuntos de ferramentas de torneamento interno | Grupos de herramientas de torneado interno

Finishing	Finishing	Finishing	Finishing	Finishing wiper	Medium to Finishing
Flat	FP	FM	FK	FW	LM
 (07)	 (07)	 (07)	 (07)	 (07)	 (07)
Medium	Medium	Medium	Finishing to Fine Finishing	Finishing to Fine Finishing	
MP	MM	MK	FS	LN	
 (07)	 (07)	 (07)	 (07)	 (07)	



Order Code		Reference	Dimensions (mm)							Insert	Kg	Stock	
R Pack	R		D	d	L1	L2	S	A	h1			Pack	R
212360000	212360100	A0810J SDQC R 07	10	8	110	32	7	12,5	9	DC.. 0702..	0,350		
	212360200	A1012K SDQC R 07	12	10	125	38	9	15,5	11	DC.. 0702..			
	212360300	A1216M SDQC R 07	16	12	150	50	11	19,5	15	DC.. 0702..			

Order Code		Reference	Dimensions (mm)							Insert	Kg	Stock	
L Pack	L		D	d	L1	L2	S	A	L1			Pack	L
212360400	212360500	A0810J SDQC L 07	10	8	110	32	7	12,5	9	DC.. 0702..	0,350		
	212360600	A1012K SDQC L 07	12	10	125	38	9	15,5	11	DC.. 0702..			
	212360700	A1216M SDQC L 07	16	12	150	50	11	19,5	15	DC.. 0702..			

 Stock Items | Itens de stock

 Available under request | Disponível sob consulta | Disponible bajo consulta







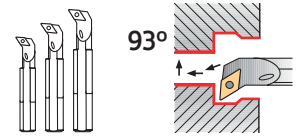

SPARE PARTS || Complementos | Repuestos

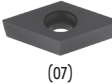
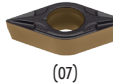
Cutter Reference	Screw	Wrench
		
A0810J SDQC R/L 07	P0200601	XT07
A1012K SDQC R/L 07	P0250700	XT07
A1216M SDQC R/L 07	P0250700	XT07

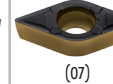
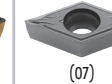

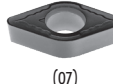

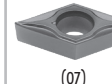
INTERNAL TOOLHOLDERS SET



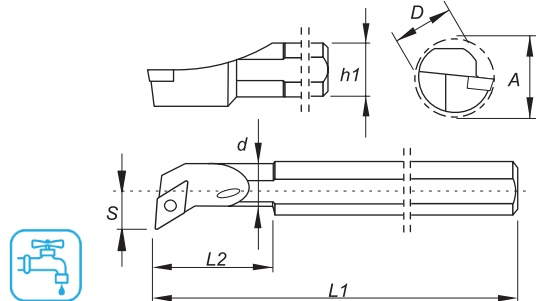

Conjuntos de ferramentas de torneamento interno | Grupos de herramientas de torneado interno





Finishing	Finishing	Finishing	Finishing	Finishing wiper	Medium to Finishing
Flat	FP	FM	FK	FW	LM
 (07)	 (07)	 (07)	 (07)	 (07)	 (07)
Medium	Medium	Medium	Finishing to Fine Finishing	Finishing to Fine Finishing	
MP	MM	MK	FS	LN	
 (07)	 (07)	 (07)	 (07)	 (07)	



Order Code		Reference	Dimensions (mm)							Insert	Kg	Stock	
R Pack	R		D	d	L1	L2	S	A	h1			Pack	R
212360800	212360900	A0810J SDUC R 07	10	8	110	32	7	12,5	9	DC.. 0702..	0,350		
	212361000	A1012K SDUC R 07	12	10	125	38	9	15,5	11	DC.. 0702..			
	212361100	A1216M SDUC R 07	16	12	150	50	11	19,5	15	DC.. 0702..			

Order Code		Reference	Dimensions (mm)							Insert	Kg	Stock	
L Pack	L		D	d	L1	L2	S	A	L1			Pack	L
212361200	212361300	A0810J SDUC L 07	10	8	110	32	7	12,5	9	DC.. 0702..	0,350		
	212361400	A1012K SDUC L 07	12	10	125	38	9	15,5	11	DC.. 0702..			
	212361500	A1216M SDUC L 07	16	12	150	50	11	19,5	15	DC.. 0702..			



 Stock Items | Itens de stock  Available under request | Disponível sob consulta | Disponible bajo consulta

SPARE PARTS || Complementos | Repuestos





Cutter Reference	Screw	Wrench
		
A0810J SDUC R/L 07	P0200601	XT07
A1012K SDUC R/L 07	P0250700	XT07
A1216M SDUC R/L 07	P0250700	XT07



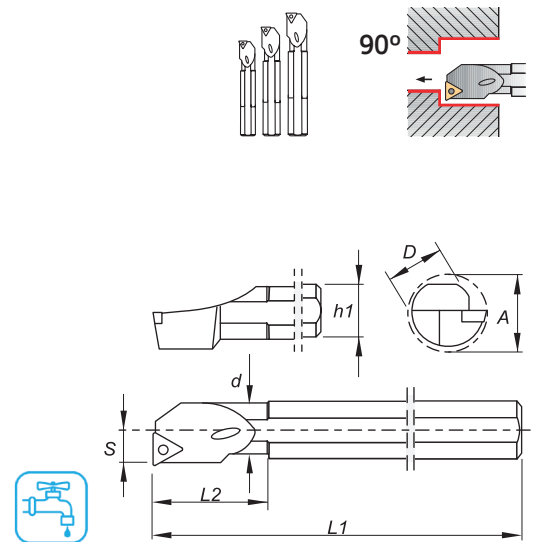

INTERNAL TOOLHOLDERS SET

Conjuntos de ferramentas de torneamento interno | Grupos de herramientas de torneado interno

Finishing	Finishing	Finishing	Finishing
Flat	FP	FM	FK
 (11)	 (11)	 (11)	 (11)
Medium	Medium	Medium	Medium to Finishing
MP	MM	MK	LN
 (11)	 (11)	 (11)	 (11)





Order Code		Reference	Dimensions (mm)							Insert	Kg	Stock	
R Pack	R		D	d	L1	L2	S	A	h1			Pack	R
212361600	212361700	A0810J STFC R 11	10	8	110	32	7	12,5	9	TC.. 1102..	0,350		
	212361800	A1012K STFC R 11	12	10	125	38	9	15,5	11	TC.. 1102..			
	212361900	A1216M STFC R 11	16	12	150	50	11	19,5	15	TC.. 1102..			

Order Code		Reference	Dimensions (mm)							Insert	Kg	Stock	
L Pack	L		D	d	L1	L2	S	A	L1			Pack	L
212362000	212362100	A0810J STFC L 11	10	8	110	32	7	12,5	9	TC.. 1102..	0,350		
	212362200	A1012K STFC L 11	12	10	125	38	9	15,5	11	TC.. 1102..			
	212362300	A1216M STFC L 11	16	12	150	50	11	19,5	15	TC.. 1102..			

 Stock Items | Itens de stock

 Available under request | Disponível sob consulta | Disponible bajo consulta

SPARE PARTS || Complementos | Repuestos

Cutter Reference	Screw	Wrench
		
A0810J STFC R/L 11	P0200601	XT07
A1012K STFC R/L 11	P0250700	XT07
A1216M STFC R/L 11	P0250700	XT07

CODE KEY FOR AUTOMATIC LATHES (ISO)

Sistema De Codificação Para Tornos Automáticos (Iso) | Codificación De Herramientas De Tornos Automáticos (Iso)

S	C	A	C	R	12	12	M	09
1	2	3	4	5	6	7	8	9

1 - Inserts Clamping System

2 - Insert Shape

80° C	55° D	75° E	55° K
R	90° S	60° T	35° V
80° W			

4 - Inserts Clearance Angle

5° B	7° C	0° N	11° P
----------------	----------------	----------------	-----------------

5 - Tool Hand

8 - Length of Holder (mm)

	D	60	P	170
	E	70	R	200
	F	80	S	250
	H	100	T	300
	K	125	U	350
	L	140	V	400
	M	150	X	Special

3 - Toolholder Leading Angle

90° A	75° B	90° C
45° D	60° E	90° F
90° G	107° 30' H	93° J
75° K	95° L	50° M
63° N	117° 30' Q	75° R
45° S	60° T	72° 30' V
113° X	100° Z	

6 - Height of Shank (mm)

7 - Width of Shank (mm)

9 - Length of Inserts Cutting Edge (mm)



C - 608 | Code Key

C - 610 | Overview

C - 611 | Center Screw Toolholders (S)

AUTOMATIC LATHES



TURNING

Insert selection

Overview

Negative inserts

Positive inserts

PCBN & PCD inserts

Heavy turning

External Toolholders

Internal Toolholders

Automatic Lathes

Spare Parts

Technical Data

CENTER SCREW TOOLHOLDERS

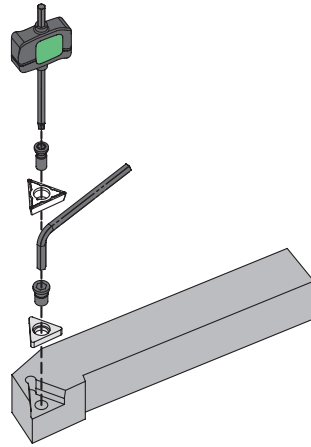

<p>SCAC 90°</p> <p>PAGE C - 687 CC.. 0602.. CC.. 09T3..</p>	<p>SCLC 95°</p> <p>PAGE C - 688 CC.. 0602.. CC.. 09T3..</p>	<p>SDAC 90°</p> <p>PAGE C - 689 DC.. 0702.. DC.. 11T3..</p>	<p>SDJC 93°</p> <p>PAGE C - 690 DC.. 0702.. DC.. 11T3..</p>	<p>SDNC 62°30'</p> <p>PAGE C - 691 DC.. 0702.. DC.. 11T3..</p>	<p>STJC 93°</p> <p>PAGE C - 692 TC.. 1102..</p>
<p>SVAC 90°</p> <p>PAGE C - 693 VC.. 1103.. VC.. 1604..</p>	<p>SVJC 93°</p> <p>PAGE C - 694 VC.. 1103.. VC.. 1604..</p>	<p>SVVC 72°30'</p> <p>PAGE C - 695 VC.. 1103..</p>			

CENTER SCREW TOOLHOLDERS

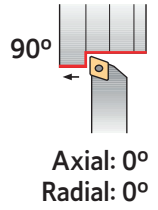

Finishing	Finishing	Finishing	Finishing	Finishing	Medium to Finishing
Flat	FP	BO	FM	FK	LM
(06-09)	(06-09)	(06-09)	(06-09)	(06-09)	(06-09)
Medium	Medium	Medium	Medium to Finishing wiper	Finishing to Fine finishing	Medium to Finishing
MP	MM	MK	MW	FS	LN
(06-09)	(06-09)	(06-09)	(06-09)	(06-09)	(06-09)

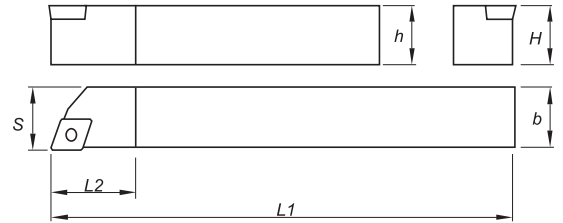

Order Code		Reference	Dimensions (mm)					Insert	Kg	Stock	
R	L		H=h	b	L1	L2	S			R	L
212251300	212251400	SCAC R/L 0808 M06	8	8	150	8	8	CC.. 0602..	0,070		
212251500	212251600	SCAC R/L 1010 M06	10	10	150	10	10	CC.. 0602..	0,110		
212251700	212251800	SCAC R/L 1212 M06	12	12	150	12	12	CC.. 0602..	0,150		
212251900	212252000	SCAC R/L 1616 M06	16	16	150	16	16	CC.. 0602..	0,280		
212252100	212252200	SCAC R/L 1212 M09	12	12	150	12	12	CC.. 09T3..	0,150		
212252300	212252400	SCAC R/L 1616 M09	16	16	150	16	16	CC.. 09T3..	0,280		

Stock Items | Itens de stock

Available under request | Disponível sob consulta | Disponible bajo consulta

SPARE PARTS || Complementos | Repuestos

Cutter Reference	Screw	Wrench
SCAC R/L 0808 M06	P0250700	XT07
SCAC R/L 1010 M06	P0250700	XT07
SCAC R/L 1212 M06	P0250700	XT07
SCAC R/L 1616 M06	P0250700	XT07
SCAC R/L 1212 M09	P0401100	XT15-S35
SCAC R/L 1616 M09	P0401100	XT15-S35

C
TURNING
Insert selection
Overview
Negative inserts
Positive inserts
PCBN & PCD inserts
Heavy turning
External Toolholders
Internal Toolholders
Automatic Lathes
Spare Parts
Technical Data

CENTER SCREW TOOLHOLDERS

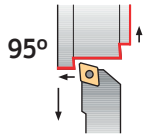

Axial: 0°
Radial: 0°

Finishing	Finishing	Finishing	Finishing	Finishing	Medium to Finishing
Flat	FP	BO	FM	FK	LM
(06-09)	(06-09)	(06-09)	(06-09)	(06-09)	(06-09)
Medium	Medium	Medium	Medium to Finishing wiper	Finishing to Fine finishing	Medium to Finishing
MP	MM	MK	MW	FS	LN
(06-09)	(06-09)	(06-09)	(06-09)	(06-09)	(06-09)

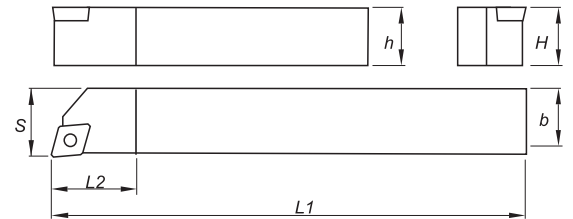

Order Code		Reference	Dimensions (mm)					Insert	Kg	Stock	
R	L		H=h	b	L1	L2	S			R	L
212252500	212252600	SCLC R/L 0808 M06	8	8	150	8	8	CC.. 0602..	0,070		
212252700	212252800	SCLC R/L 1010 M06	10	10	150	10	10	CC.. 0602..	0,110		
212252900	212253000	SCLC R/L 1212 M06	12	12	150	12	12	CC.. 0602..	0,150		
212253100	212253200	SCLC R/L 1616 M06	16	16	150	16	16	CC.. 0602..	0,280		
212253300	212253400	SCLC R/L 1212 M09	12	12	150	12	12	CC.. 09T3..	0,150		
212253500	212250400	SCLC R/L 1616 M09	16	16	150	16	16	CC.. 09T3..	0,280		

Stock Items | Itens de stock







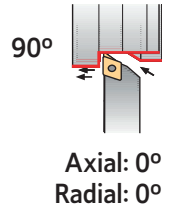

Available under request | Disponível sob consulta | Disponible bajo consulta

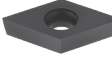
SPARE PARTS | Complementos | Repuestos







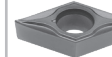
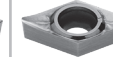

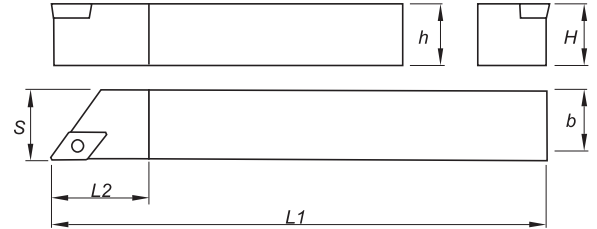



Cutter Reference	Screw	Wrench
SCLC R/L 0808 M06	P0250700	XT07
SCLC R/L 1010 M06	P0250700	XT07
SCLC R/L 1212 M06	P0250700	XT07
SCLC R/L 1616 M06	P0250700	XT07
SCLC R/L 1212 M09	P0401100	XT15-S35
SCLC R/L 1616 M09	P0401100	XT15-S35

CENTER SCREW TOOLHOLDERS



Finishing	Finishing	Finishing	Finishing	Medium to Finishing
Flat	FP	FM	FK	LM
 (07-11)	 (07-11)	 (07-11)	 (07-11)	 (07-11)
Medium	Medium	Medium	Finishing to Fine Finishing	Finishing to Fine Finishing
MP	MM	MK	FS	LN
 (07-11)	 (07-11)	 (07-11)	 (07-11)	 (07-11)





Order Code		Reference	Dimensions (mm)					Insert	Kg	Stock	
R	L		H=h	b	L1	L2	S			R	L
212253600	212253700	SDAC R/L 0808 M07	8	8	150	12,7	8	DC.. 0702..	0,070		
212253800	212253900	SDAC R/L 1010 M07	10	10	150	15,0	10	DC.. 0702..	0,110		
212254000	212254100	SDAC R/L 1212 M07	12	12	150	15,0	12	DC.. 0702..	0,150		
212254200	212254300	SDAC R/L 1616 M07	16	16	150	16,0	16	DC.. 0702..	0,280		
212254400	212254500	SDAC R/L 1212 M11	12	12	150	18,0	12	DC.. 11T3..	0,150		
212254600	212254700	SDAC R/L 1616 M11	16	16	150	20,0	16	DC.. 11T3..	0,280		

 Stock Items | Itens de stock

 Available under request | Disponível sob consulta | Disponible bajo consulta

SPARE PARTS | Complementos | Repuestos







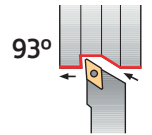

Cutter Reference	Screw	Wrench
		
SDAC R/L 0808 M07	P0250700	XT07
SDAC R/L 1010 M07	P0250700	XT07
SDAC R/L 1212 M07	P0250700	XT07
SDAC R/L 1616 M07	P0250700	XT07
SDAC R/L 1212 M11	P0401100	XT15-S35
SDAC R/L 1616 M11	P0401100	XT15-S35

C
TURNING
Insert selection
Overview
Negative inserts
Positive inserts
PCBN & PCD inserts
Heavy turning
External Toolholders
Internal Toolholders
Automatic Lathes
Spare Parts
Technical Data



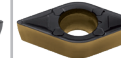
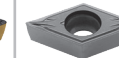



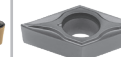
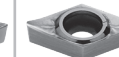

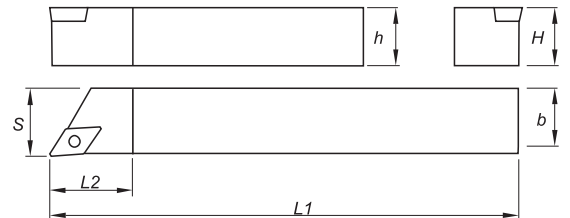



CENTER SCREW TOOLHOLDERS



Axial: 0°
Radial: 0°

Finishing	Finishing	Finishing	Finishing	Finishing wiper	Medium to Finishing
Flat	FP	FM	FK	FW	LM
 (07-11)	 (07-11)	 (07-11)	 (07-11)	 (07-11)	 (07-11)
Medium	Medium	Medium	Medium to Finishing wiper	Finishing to Fine Finishing	Finishing to Fine Finishing
MP	MM	MK	MW	FS	LN
 (07-11)	 (07-11)	 (07-11)	 (11)	 (07-11)	 (07-11)



Order Code		Reference	Dimensions (mm)					Insert	Kg	Stock	
R	L		H=h	b	L1	L2	S			R	L
212254800	212254900	SDJC R/L 0808 M07	8	8	150	8	8	DC.. 0702..	0,070		
212255000	212255100	SDJC R/L 1010 M07	10	10	150	10	10	DC.. 0702..	0,110		
212255200	212255300	SDJC R/L 1212 M07	12	12	150	12	12	DC.. 0702..	0,150		
212255400	212255500	SDJC R/L 1616 M07	16	16	150	16	16	DC.. 0702..	0,280		
212255600	212255700	SDJC R/L 1212 M11	12	12	150	12	12	DC.. 11T3..	0,150		
212255800	212255900	SDJC R/L 1616 M11	16	16	150	16	16	DC.. 11T3..	0,280		

 Stock Items | Itens de stock  Available under request | Disponível sob consulta | Disponible bajo consulta

SPARE PARTS | Complementos | Repuestos

Cutter Reference	Screw	Wrench
		
SDJC R/L 0808 M07	P0250700	XT07
SDJC R/L 1010 M07	P0250700	XT07
SDJC R/L 1212 M07	P0250700	XT07
SDJC R/L 1616 M07	P0250700	XT07
SDJC R/L 1212 M11	P0401100	XT15-S35
SDJC R/L 1616 M11	P0401100	XT15-S35

CENTER SCREW TOOLHOLDERS

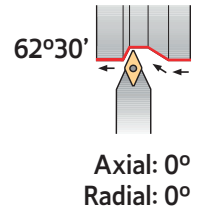

Finishing	Finishing	Finishing	Finishing	Medium to Finishing
Flat	FP	FM	FK	LM
(07-11)	(07-11)	(07-11)	(07-11)	(07-11)
Medium	Medium	Medium	Finishing to Fine Finishing	Finishing to Fine Finishing
MP	MM	MK	FS	LN
(07-11)	(07-11)	(07-11)	(07-11)	(07-11)

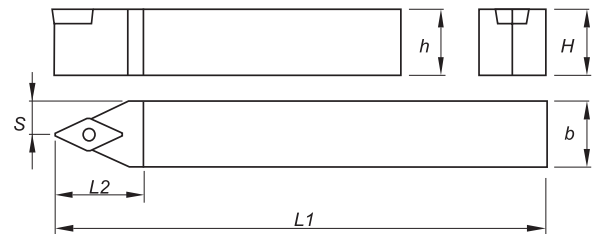

Order Code	Reference	Dimensions (mm)					Insert	Kg	Stock
		H=h	b	L1	L2	S			
212256000	SDNC N 1010 M07	10	10	150	15	5,2	DC.. 0702..	0,100	
212256100	SDNC N 1212 M11	12	12	150	21	6,2	DC.. 11T3..	0,140	
212256200	SDNC N 1616 M11	16	16	150	21	8,6	DC.. 11T3..	0,270	

Stock Items | Itens de stock







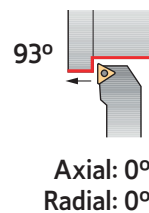

Available under request | Disponível sob consulta | Disponible bajo consulta

SPARE PARTS | Complementos | Repuestos





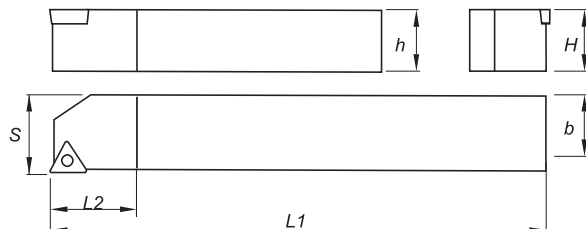

Cutter Reference	Screw	Wrench
SDNC N 1010 M07	P0250700	XT07
SDNC N 1212 M11	P0401100	XT15-S35
SDNC N 1616 M11	P0401100	XT15-S35

CENTER SCREW TOOLHOLDERS



Finishing	Finishing	Finishing	Finishing	Finishing wiper
Flat  (09-11-16)	FP  (09-11-16)	FM  (09-11-16)	FK  (09-11-16)	FW  (09-11-16)
Medium	Medium	Medium	Medium to Finishing	
MP  (09-11-16)	MM  (09-11-16)	MK  (09-11-16)	LN  (11-16)	





Order Code		Reference	Dimensions (mm)					Insert	Kg	Stock	
R	L		H=h	b	L1	L2	S			R	L
212256300	212256400	STJC R/L 1010 M11	10	10	150	16	10	TC.. 1102..	0,110		
212256500	212256600	STJC R/L 1212 M11	12	12	150	16	12	TC.. 1102..	0,150		
212256700	212256800	STJC R/L 1616 M11	16	16	150	16	16	TC.. 1102..	0,280		

 Stock Items | Itens de stock





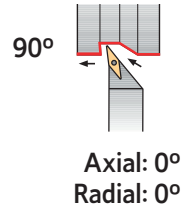

 Available under request | Disponível sob consulta | Disponible bajo consulta

SPARE PARTS | Complementos | Repuestos

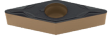







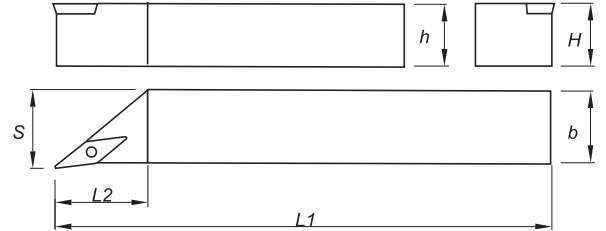



Cutter Reference	Screw 	Wrench 
STJC R/L 1010 M11	P0250700	XT07
STJC R/L 1212 M11	P0250700	XT07
STJC R/L 1616 M11	P0250700	XT07

CENTER SCREW TOOLHOLDERS



Finishing	Finishing	Finishing	Finishing
Flat	FP	FM	FK
 (11-16)	 (11-16)	 (11-16)	 (11-16)
Medium	Medium	Medium	Medium to Finishing
MP	MM	MK	LN
 (11-16)	 (11-16)	 (11-16)	 (11-16)



Order Code		Reference	Dimensions (mm)					Insert	Kg	Stock	
R	L		H=h	b	L1	L2	S			R	L
212256900	212257000	SVAC R/L 0808 M11	8	8	150	26	8	VC.. 1103..	0,070		
212257100	212257200	SVAC R/L 1010 M11	10	10	150	26	10	VC.. 1103..	0,100		
212257300	212257400	SVAC R/L 1212 M11	12	12	150	26	12	VC.. 1103..	0,140		
212257500	212257600	SVAC R/L 1616 M11	16	16	150	26	16	VC.. 1103..	0,270		
212257700	212257800	SVAC R/L 1212 M16	12	12	150	40	12	VC.. 1604..	0,140		
212257900	212258000	SVAC R/L 1616 M16	16	16	150	40	16	VC.. 1604..	0,270		

 Stock Items | Itens de stock

 Available under request | Disponível sob consulta | Disponible bajo consulta

SPARE PARTS | Complementos | Repuestos





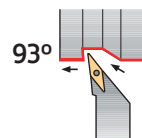

Cutter Reference	Screw	Wrench
		
SVAC R/L 0808 M11	P0250700	XT07
SVAC R/L 1010 M11	P0250700	XT07
SVAC R/L 1212 M11	P0250700	XT07
SVAC R/L 1616 M11	P0250700	XT07
SVAC R/L 1212 M16	P0401100	XT15-S35
SVAC R/L 1616 M16	P0401100	XT15-S35

C
TURNING
Insert selection
Overview
Negative inserts
Positive inserts
PCBN & PCD inserts
Heavy turning
External Toolholders
Internal Toolholders
Automatic Lathes
Spare Parts
Technical Data

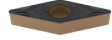







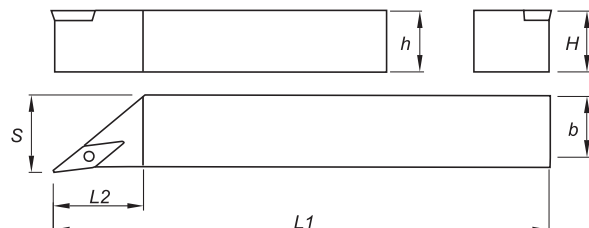



CENTER SCREW TOOLHOLDERS



Axial: 0°
Radial: 0°

Finishing	Finishing	Finishing	Finishing
Flat  (11-16)	FP  (11-16)	FM  (11-16)	FK  (11-16)
Medium	Medium	Medium	Medium to Finishing
MP  (11-16)	MM  (11-16)	MK  (11-16)	LN  (11-16)



Order Code		Reference	Dimensions (mm)					Insert	Kg	Stock	
R	L		H=h	b	L1	L2	S			R	L
212258100	212258200	SVJC R/L 0808 M11	8	8	150	26	8	VC.. 1103..	0,070		
212258300	212258400	SVJC R/L 1010 M11	10	10	150	26	10	VC.. 1103..	0,100		
212258500	212258600	SVJC R/L 1212 M11	12	12	150	26	12	VC.. 1103..	0,140		
212258700	212258800	SVJC R/L 1616 M11	16	16	150	26	16	VC.. 1103..	0,270		
212258900	212259000	SVJC R/L 1212 M16	12	12	150	40	12	VC.. 1604..	0,140		
212259100	212259200	SVJC R/L 1616 M16	16	16	150	40	16	VC.. 1604..	0,270		

 Stock Items | Itens de stock

Available under request | Disponível sob consulta | Disponible bajo consulta

SPARE PARTS | Complementos | Repuestos



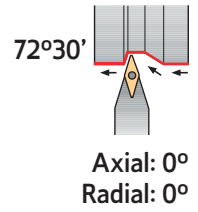

Cutter Reference	Screw	Wrench
		
SVJC R/L 0808 M11	P0250700	XT07
SVJC R/L 1010 M11	P0250700	XT07
SVJC R/L 1212 M11	P0250700	XT07
SVJC R/L 1616 M11	P0250700	XT07
SVJC R/L 1212 M16	P0401100	XT15-S35
SVJC R/L 1616 M16	P0401100	XT15-S35

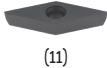
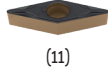
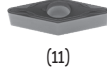
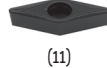
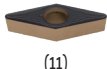
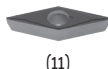
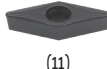
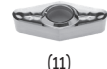
CENTER SCREW TOOLHOLDERS

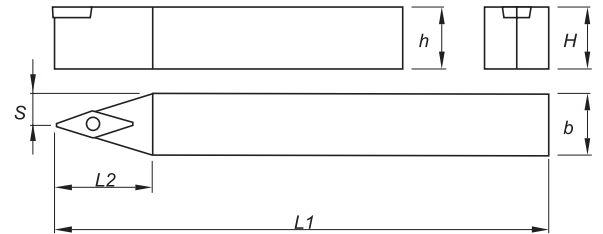

Finishing	Finishing	Finishing	Finishing
Flat	FP	FM	FK
 (11)	 (11)	 (11)	 (11)
Medium	Medium	Medium	Medium to Finishing
MP	MM	MK	LN
 (11)	 (11)	 (11)	 (11)



Order Code	Reference	Dimensions (mm)					Insert	Kg	Stock
		H=h	b	L1	L2	S			
212259300	SVVC N 0808 M11	8	8	150	21	4,3	VC.. 1103..	0,070	
212259400	SVVC N 1010 M11	10	10	150	21	5,3	VC.. 1103..	0,100	
212259500	SVVC N 1212 M11	12	12	150	21	6,3	VC.. 1103..	0,140	
212259600	SVVC N 1616 M11	16	16	150	21	8,3	VC.. 1103..	0,260	

 Stock Items | Itens de stock

 Available under request | Disponível sob consulta | Disponible bajo consulta

SPARE PARTS | Complementos | Repuestos

Cutter Reference	Screw	Wrench
		
SVVC N 0808 M11	P0250700	XT07
SVVC N 1010 M11	P0250700	XT07
SVVC N 1212 M11	P0250700	XT07
SVVC N 1616 M11	P0250700	XT07

SPARE PARTS

CHIP BREAKERS | Quebra Aparas | Rompevirutas

QCS0900 290071500 	QCS1200 290071700 	QCS1201 290072200 	QCS1900 290071900 	QCS1901 290072400 	QCS0901 290072600
QCS0902 290072900 	QCS1202 290072700 	QCT1100 290071600 	QCT1101 290072100 	QCT1600 290071800 	QCT1601 290072300
QCT2200 290072000 	QCT2201 290072500 				
GS03000 290065100 	GS04000 290009700 	GS05002 290065900 	GS05000 290055800 	GS05004 290066500 	GS05001 290065800
GS05003 290066000 	GS06001 290047700 	GS06002 290046300 	GS06003 290066200 	GS06000 290010500 	GS05005 290005900
GS08001 290066600 	GS08000 290030100 				

GA05001
290082000

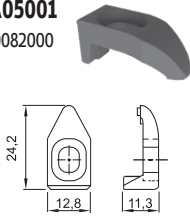

GA07002
290082100

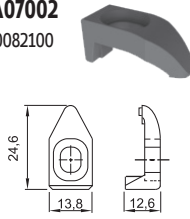

GA07001
290066300

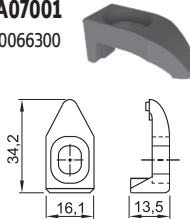

GA07003
290082200

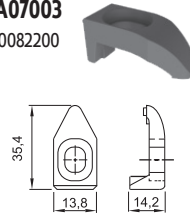

GAW1400
290031800

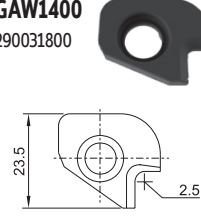

GAW1401
290066400

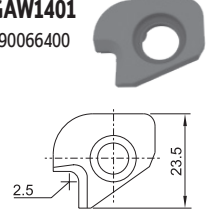

DIFFERENTIALS SCREWS | Parafusos Diferenciales | Tornillos Diferenciales

F0602100
290062700
Allen 3

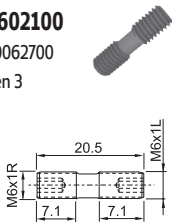

F0802900
290062300
Allen 4

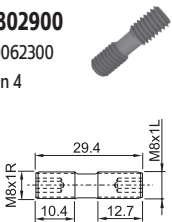

F0602100
290062700
Allen 3

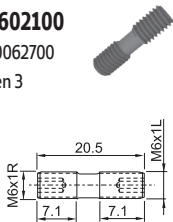

LEVERS | Alavanca | Palanca

AN07800
290048700

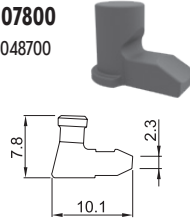

AN01200
290031200

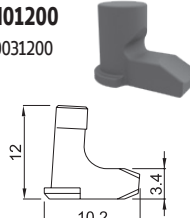

AN13100
290009000

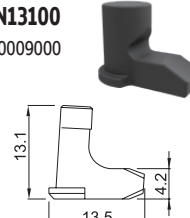

AN17100
290047200

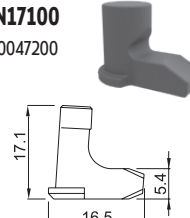

AN17200
290070500



AN20800
290047300



AN25200
290070600

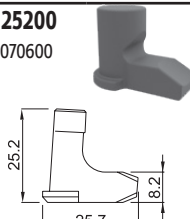

AN14700
290071400

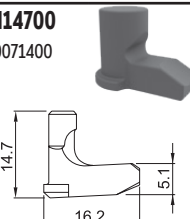

AN09500
290052800

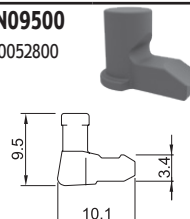

AC11700
290019200

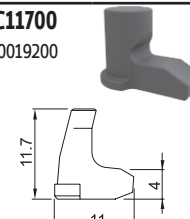

AC13300
290019300

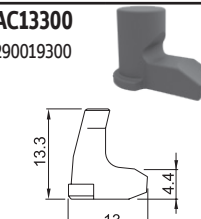

AC18700
290070800

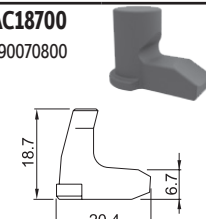

AC23000
290070900

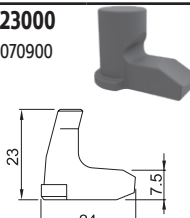

AC26700
290071000

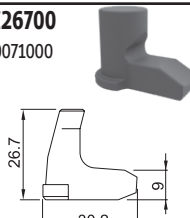

AC13200
290071300

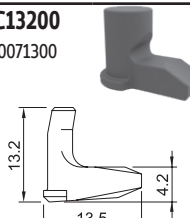

AC18000
290070700

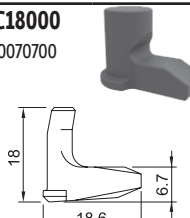

AN12100
290071100

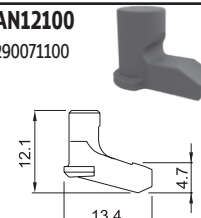

AN20200
290071200

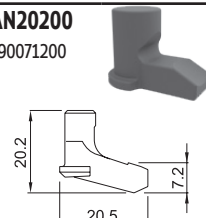

SPARE PARTS

LEVER SCREWS | Parafusos Para Alavanca | Tornillos De Palanca

PA0501000 290048800 Allen 2 	PA0501200 290063000 Allen 2 	PA0501400 290019000 Allen 2 	PA0601300 290063200 Allen 2,5 	PA0601700 290018900 Allen 2,5 	PA0602100 290064400 Allen 2,5
PA0801700 290063800 Allen 3 	PA0802100 290011900 Allen 3 	PA0802101 290063300 Allen 3 	PA0802300 290047100 Allen 3 	PA0802400 290064500 Allen 3 	PA1002700 290048600 Allen 4
PA1003000 290064600 Allen 4 	PA1203600 290063100 Allen 5 				

LOCK PINS | Cavilhas De Bloqueio | Pines De Bloqueo

BC04502 290063500 	BC04501 290063600 	BC04500 290063400 	BC06001 290063700 	BC06000 290053500 	BC08000 290064200
BS05000 290054400 Allen 2 	BS1-402 290064300 Allen 2,5 	BS1-400 290063900 Allen 2,5 	BS1-401 290064000 Allen 2,5 	BS3-800 290064100 Allen 4 	

SCREWS (ALLEN) | Parafusos (Allen) | Tornillos (Allen)

<p>D0300700 290012000 Allen 5</p>	<p>D0300691 290064800 Allen 2</p>	<p>D0301101 290094500 Allen 2.5</p>	<p>D0400691 290064900 Allen 2.5</p>	<p>D0400900 290053700 Allen 5</p>	<p>D0500801 290082700 Allen 5</p>
<p>D0601400 290062800 Allen 5</p>	<p>D0601600 290083000 Allen 4</p>	<p>D0602200 290062900 Allen 5</p>	<p>D0602900 290082900 Allen 4</p>	<p>D0702800 290048100 Allen 4</p>	<p>DW142600 290018200 Allen 4</p>
<p>T05003500 290020100 Allen 3.5</p>	<p>T05008000 290082300 Allen 2</p>	<p>T06010000 290082400 Allen 2.5</p>	<p>T06004000 290008700 Allen 4</p>	<p>T06015000 290082500 Allen 3</p>	<p>T1000875 290086000 Allen 5</p>
<p>H0600475 290085800 Allen 3</p>	<p>H1000875 290085900 Allen 5</p>				

SCREWS (TORX) | Parafusos (torx) | Tornillos (torx)

<p>P0220600 290026000 TorxT-6</p>	<p>P0250700 290013400 TorxT-7</p>	<p>P0200601 290010700 TorxT-7</p>	<p>P0300900 290007500 TorxT-8</p>	<p>P0351500 290020000 TorxT-15</p>	<p>P0401400 290031100 TorxT-15</p>
<p>P0400802 290006500 TorxT-15</p>	<p>P0401100 290007000 TorxT-15</p>	<p>P0501200 290026200 TorxT-20</p>	<p>P0801411 290062600 TorxT-25</p>		

SPARE PARTS

SHIM PINS | Pino calço | Pino cuña

BE02100 290020500 	BE03000 290038900 	BE04400 290007300 	BE05500 290069200 	BE03800 290019100 	BE05401 290069900
BE08300 290069700 	BE07000 290069300 	BE05400 290069400 	BE08301 290069800 	BE08500 290069500 	BE10500 290069600
BF04806 290070000 	BF04808 290070100 	BF04813 290018100 	BF04815 290070200 		

SHIM PIN PUNCHES | Calço | Cuña

BF40009 290033200 	BF47509 290020600 	BF65012 290061900 	BF80012 290062000 	BF12520 290062100
---------------------------------	---------------------------------	---------------------------------	---------------------------------	---------------------------------

SHIMS (C SHAPES) | Colchões (Pastilhas C) | Placas Base (Plaquetas C)

CC090300 290067800 	CC120301 212127000 	CC160500 290046400 	CC190500 212169300 	CC250700 290067900 	CC120401 212166800
CC120600 290083200 	CC120500 290055200 	CC120300 290083300 	CC190502 290073200 		

SHIMS (D SHAPES) | Colchões (Pastilhas D) | Placas Base (Plaquetas D)

<p>CD110300 290068000</p>	<p>CD110301 212166900</p>	<p>CD110302 290083400</p>	<p>CD150300 290068100</p>	<p>CD150500 290068200</p>	<p>CD150501 290073300</p>
<p>CD150502 116021623</p>	<p>CD150503 116021723</p>				

SHIMS (R SHAPES) | Colchões (Pastilhas R) | Placas Base (Plaquetas R)

<p>CR090300 290068700</p>	<p>CR100300 212054600</p>	<p>CR100301 212167100</p>	<p>CR120300 212054700</p>	<p>CR120301 212167200</p>	<p>CR120302 290068800</p>
<p>CR150500 290068900</p>	<p>CR160500 290068300</p>	<p>CR190500 290069000</p>	<p>CR200500 290068400</p>	<p>CR250600 290068500</p>	<p>CR250601 290069100</p>
<p>CR320600 290068600</p>					

SHIMS (S SHAPES) | Colchões (Pastilhas S) | Placas Base (Plaquetas S)

<p>CS090300 290067100</p>	<p>CS090301 290067500</p>	<p>CS120300 212056100</p>	<p>CS120400 212044300</p>	<p>CS120302 290067600</p>	<p>CS120500 290053800</p>
<p>CS120600 290083500</p>	<p>CS150400 290083900</p>	<p>CS190501 290083600</p>	<p>CS190300 290067200</p>	<p>CS190400 290084000</p>	<p>CS250600 290053000</p>

SPARE PARTS

SHIMS (T SHAPES) | Colchões (Pastilhas T) | Placas Base (Plaquetas T)

CT160301 212026000 	CT160303 212039600 	CT160302 212039900 	CT160304 290073400 	CT160600 290083700 	CT220301 212127500
CT220302 290061700 	CT220500 290052700 	CT220600 290083800 	CT270500 290061500 	CT330500 290067400 	

SHIMS (V SHAPES) | Colchões (Pastilhas V) | Placas Base (Plaquetas V)

CV160301 290054300 	CV160300 212044400 	CV220400 212167000
----------------------------------	----------------------------------	----------------------------------

SHIMS (W SHAPES) | Colchões (Pastilhas W) | Placas Base (Plaquetas W)

CW060301 212169100 	CW060300 290067000 	CW080300 212169200 	CW080500 290053400
----------------------------------	----------------------------------	----------------------------------	----------------------------------

SHIMS (KNUX SHAPES) | Colchões (Pastilhas Knux) | Placas Base (Plaquetas Knux)

CK160500 212127100 	CK160501 290067300
----------------------------------	----------------------------------

SPRINGS | Mola | Muelle

M06511 290070300 	M09513 290054100
--------------------------------	--------------------------------

WEDGE CLAMPS (M HOLDERS) | Grampos Cunhas (Suportes M) | Tornillos Para Cuñas (Soportes M)

<p>GW05000 290065200</p>	<p>GW08000 290053300</p>	<p>GW08001 290065300</p>	<p>GW08002 290009400</p>	<p>GW08003 290065700</p>
-------------------------------------	-------------------------------------	-------------------------------------	-------------------------------------	-------------------------------------

WEDGE CLAMPS (M-K HOLDERS) | Grampos Cunhas (Suportes M-K) | Tornillos Para Cuñas (Soportes M-K)

<p>GW05001 290065400</p>	<p>GW06000 290065500</p>	<p>GW06001 290065600</p>	<p>GA06000 290066700</p>	<p>GA06001 290066800</p>	<p>GA06002 290053600</p>
<p>GA06003 290066900</p>					

WRENCHES (ALLEN) | Chaves (Allen) | Llaves (Allen)

<p>SS15 290070400 Allen 1,5</p>	<p>SS20 290020300 Allen 2</p>	<p>SS25 290019800 Allen 2,5</p>	<p>SS30 290038400 Allen 3</p>	<p>SS40 290021200 Allen 4</p>	<p>SS50 290021300 Allen 5</p>
--	--	--	--	--	--

WRENCHES (TORX) | Chaves (Torx) | Llaves (Torx)

<p>XT07 290012900 Torx 7</p>	<p>XT08 290011700 Torx 8</p>	<p>XT15-S35 290012400 Torx 15 & Allen 3,5</p>	<p>XT15-S40 290046500 Torx 15 & Allen 4</p>	<p>XT20-S40 290013200 Torx 20 & Allen 4</p>
---	---	--	--	--