

# UC

BRAND NEW GOLD CHUCK  
AN EXCITING RESULT.

—  
一種全新感受的刀柄  
創造令人振奮的成績







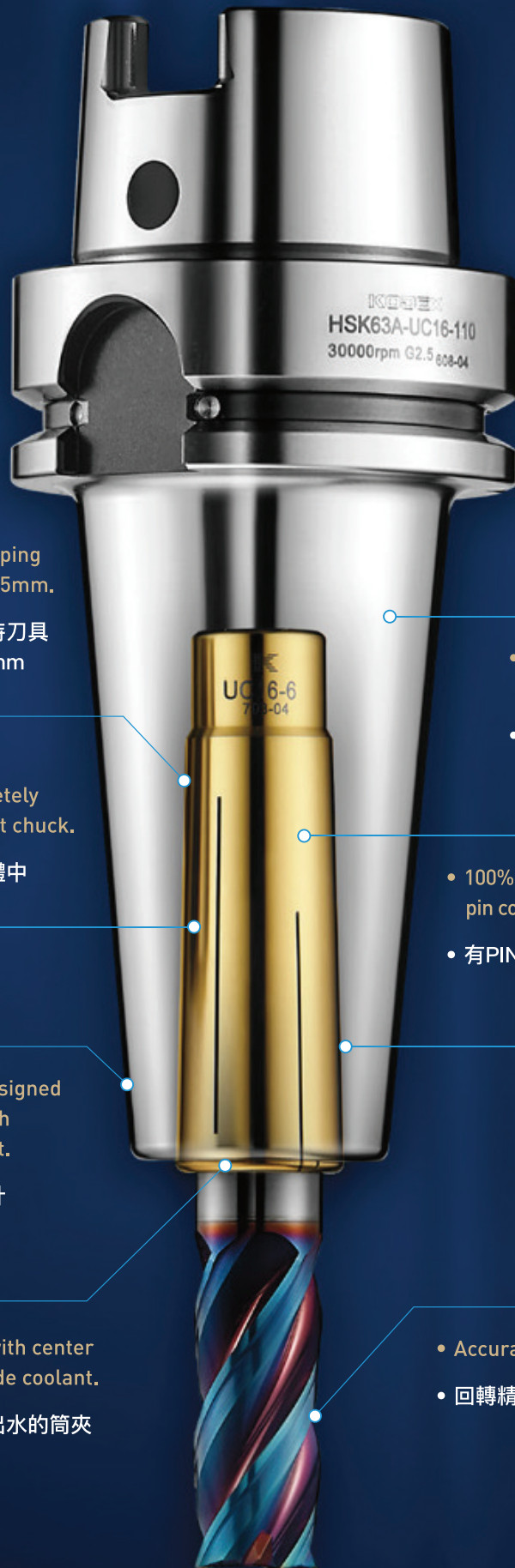

- Complete tool clamping range from 3mm~25mm.

- 規格種類齊全，夾持刀具的範圍：3mm~25mm

- The collet is completely covered in the collet chuck.

- 筒夾完全包覆在本體中

- The collet chuck designed without nut and with inner-holding collet.

- 沒有螺帽的刀柄設計

- Provide the collet with center coolant and with side coolant.

- 有中心出水及側面出水的筒夾可供選擇

- Excellent vibration damping of performance.

- 極佳的阻尼減震性能

- 100% never tool pull out for the pin collet.

- 有PIN的筒夾設計，100%不掉刀

- The inner-holding collet designed of small angle.

- 小角度的後拉式筒夾設計

- Accuracy < 0.005mm ( 4XD )

- 回轉精度在0.005mm以下 ( 4XD )

## RUN OUT

Accuracy within 0.005mm at 4 times length of cutter edge to ensure uniform an even cutting action, increasing cutting speed and tool life.

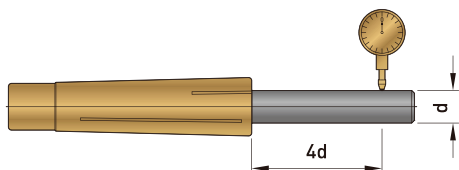

## 回轉精度

4倍刃長精度在0.005mm以內，確保切削時每刃刀口的均勻切削，可使切削速度提高及刀具壽命增加。

## CHOICE OF COOLING MODE

Provide the collet with center coolant and with side coolant.

### — 冷却方式的選擇

有中心出水及側面出水的筒夾，可供選擇。

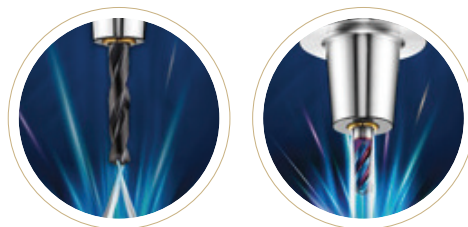

## EXCELLENT VIBRATION DAMPING OF PERFORMANCE

The inner-holding collet designed of small angle can completely covered in the collet chuck that can increasing clamping force and having the excellent vibration damping of performance for get the maximum benefit from the machine and tools.



### — 極佳的阻尼減震性能

小角度後拉式筒夾設計，筒夾完全包覆在本體內，鎖固力量大，具有極佳的阻尼減震性能，可使機床及刀具發揮到最大的效益。

## INNOVATION DESIGNED AND 100% NEVER TOOL PULL OUT

The collet designed with pin can be fixed the standard side lock tool (DIN6535HB) or grinded R groove at tools with excellent vibration damping and 100% never tool pull out.

### — 創新設計，100%不掉刀

有PIN的筒夾設計，可以固定標準側固刀具 [DIN6535HB] 或者自行在柄部研磨R型溝槽，具有極佳的阻尼減震及100%不掉刀的雙重效果。

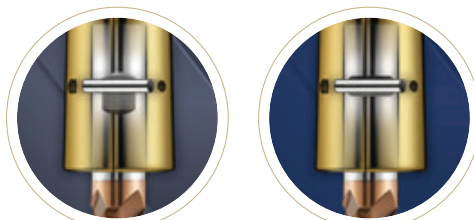

WELDON TYPE

R GROOVE

## KOJEX IS THE INITIATOR OF INNER-HOLDING COLLET CHUCKS

The simple structure can reduces interference and more stable when the cutting processing.

### — 廣傑獨創

沒有螺帽的筒夾設計  
沒有螺帽的筒夾設計，結構簡單減少干涉，切削時更為安定。



## COMPLETE VARIETY

Either the slim extension or the vibration damping tool holder has the clamping range from 3 mm to 25 mm.

### — 規格種類齊全

無論小徑加長型或減震阻尼型均有，刀具夾持範圍：  
3mm~25 mm



# UC GOLD CHUCK

UC 黃金夾頭刀柄

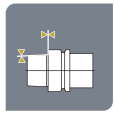
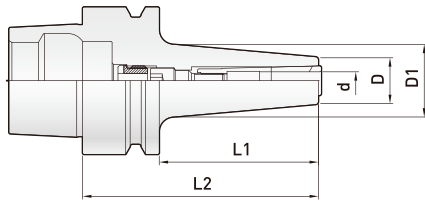

Dual face contact  
兩面接觸



Surface roughness  
表面粗度

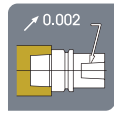

Run out accuracy  
內孔偏擺度



Surface hardness  
表面硬度

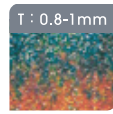

Carbonized depth  
滲碳深度

Order Code 訂購編號	Range(d) 夾持範圍	L	L1	D	D1	Min <sup>-1</sup> G2.5 動態平衡	Spanner 扳手規格	Recommended Torsion 推薦鎖固扭力	Fixed Torque Spanner 固定扭力扳手
HSK40E-UC6-80	3~6	80	60	16	26	42,000	M4	5Nm	30294-5144
UC10-90	3~10	90	90	24	32	42,000	M5	7Nm	30294-5152
HSK50E-UC6-80	3~6	80	54	16	25	36,000	M4	5Nm	30294-5144
UC10-90	3~10	90	64	24	35	36,000	M5	7Nm	30294-5152

- Collet chuck designed without nut and with inner-holding collet. This has strong rigidity and high stability.
- Torque wrench is recommended for chuck stability.
- Torque wrench must be ordered separately.
- The recommended torsion and correct torque wrench prevents deformation of the tool holder.

- 沒有螺帽的後拉式夾頭設計，鋼性強穩定性高。
- 為求使用上的穩定性，建議使用扭力扳手。
- 扭力扳手必須另外訂購。
- 鎖固扭力不要超過推薦值的30%以上，過高的鎖固扭力，可能導致刀柄的變形。



# UC GOLD CHUCK ( Slim Long Type )

UC 黃金夾頭刀柄 (小徑加長型)

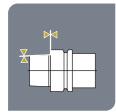
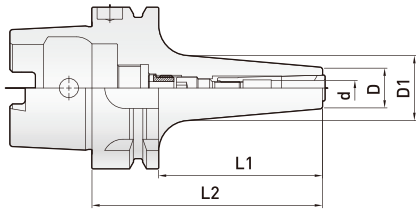

Dual face contact  
兩面接觸



Surface roughness  
表面粗度

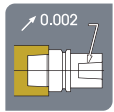

Run out accuracy  
內孔偏擺度



Surface hardness  
表面硬度

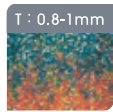

Carbonized depth  
滲碳深度

Order Code 訂購編號	Range(d) 夾持範圍	L	L1	D	D1	Min <sup>1</sup> G2.5 動態平衡	Spanner 扳手規格	Recommended Torsion 推薦鎖固扭力	Fixed Torque Spanner 固定扭力扳手
HSK63A-UC6-90	3~6	90	64	16	26	30,000	M4	5Nm	30294-5146
UC6-120	3~6	120	94	16	32	30,000	M4	5Nm	30294-5146
UC6-150	3~6	150	124	16	37	30,000	M4	5Nm	30294-5146
HSK63A-UC10-100	3~10	100	74	24	34	30,000	M5	7Nm	30294-5154
UC10-120	3~10	120	94	24	40	30,000	M5	7Nm	30294-5156
UC10-150	3~10	150	124	24	46	30,000	M5	7Nm	30294-5156

- Collet chuck designed without nut and with inner-holding collet. This has strong rigidity and high stability.
- Torque wrench is recommended for chuck stability.
- Torque wrench must be ordered separately.
- The recommended torsion and correct torque wrench prevents deformation of the tool holder.

- 沒有螺帽的後拉式夾頭設計，鋼性強穩定性高。
- 為求使用上的穩定性，建議使用扭力扳手。
- 扭力扳手必須另外訂購。
- 鎖固扭力不要超過推薦值的30%以上，過高的鎖固扭力，可能導致刀柄的變形。



UC

HSK

A63



# UC GOLD CHUCK ( UC16 ) High Vibration Damping Type

UC 黃金夾頭刀柄 (UC16) 高阻尼減震型

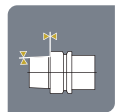
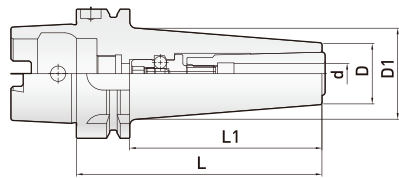

Dual face contact  
兩面接觸

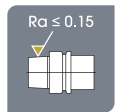

Surface roughness  
表面粗度

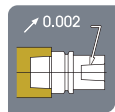

Run out accuracy  
內孔偏擺度



Surface hardness  
表面硬度

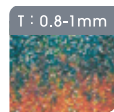

Carbonized depth  
滲碳深度



Order Code 訂購編號	Range(d) 夾持範圍	L	L1	D	D1	Min <sup>1</sup> G2.5 動態平衡	Spanner 扳手規格	Recommended Torsion 推薦鎖固扭力	Torque Wrench 扭力扳手	Center Coolant 中心出水	Side Coolant 側面出水	Pin Collet Pin 筒夾
HSK63A-UC16-120	6~16	120	94	32	47	30,000	M6	15Nm	TW30+M06100	✓	✓	X
HSK100A-UC16-150	6~16	150	121	32	49	20,000	M6	15Nm	TW30+M06160	✓	✓	X

- Provide the center coolant and the side coolant.
- Select the side coolant must use the collet with coolant slot, please check p.20
- Select the general collet for center coolant, please check p.19
- Coolant can be sprayed directly into the edge of tool for quick cooling and remove the steel chip.
- 可以選擇中心出水及側面出水的功能。
- 側面出水必須選用有水槽的夾頭，請參閱 p.20
- 中心出水選用一般的夾頭，請參閱 p.19
- 冷卻液可直接噴到刀尖位置，可快速冷卻及去除鐵屑。



# UC GOLD CHUCK ( UC20 ) High Vibration Damping Type

UC 黃金夾頭刀柄 (UC20) 高阻尼減震型

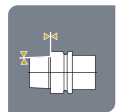
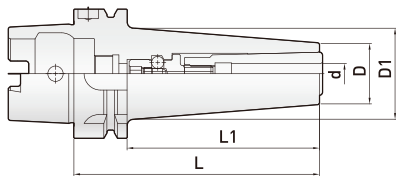

Dual face contact  
兩面接觸



Surface roughness  
表面粗度

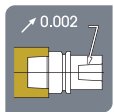

Run out accuracy  
內孔偏擺度



Surface hardness  
表面硬度

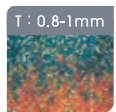

Carbonized depth  
滲碳深度

Order Code 訂購編號	Range(d) 夾持範圍	L	L1	D	D1	Min <sup>-1</sup> G2.5 動態平衡	Spanner 扳手規格	Recommended Torsion 推薦鎖固扭力	Torque Wrench 扭力扳手	Center Coolant 中心出水	Side Coolant 側面出水	Pin Collet Pin筒夾
HSK63A-UC20-130	6~20	130	104	45	53	30,000	M8	20Nm	TW30+M08100	✓	✓	✓
HSK100A-UC20-150	6~20	150	121	45	54	20,000	M8	20Nm	TW30+M08160	✓	✓	✓

- Provide the center coolant and the side coolant.
- Select the side coolant must use the collet with coolant slot, please check p.20
- Select the general collet for center coolant, please check p.19
- Select the PIN Collet, please check p.21
- Coolant can be sprayed directly into the edge of tool for quick cooling and remove the steel chip.

- 可以選擇中心出水及側面出水的功能。
- 側面出水必須選用有水槽的夾頭，請參閱 p.20
- 中心出水選用一般的夾頭，請參閱 p.19
- 可以選用PIN Collet，請參閱 p.21
- 冷卻液可直接噴到刀尖位置，可快速冷卻及去除鐵屑。



UC  
20

HSK  
A  
63  
/  
100



# UC PIN COLLET CHUCK ( UC25 ) High Vibration Damping Type

UC 安卡夾頭 (UC25) 高阻尼減震型

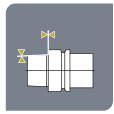
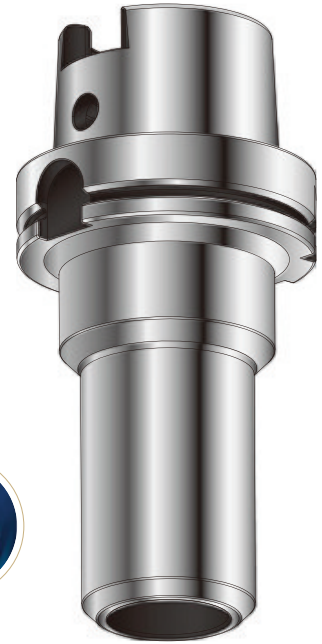
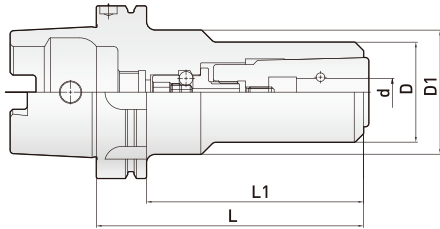

Dual face contact  
兩面接觸



Surface roughness  
表面粗度

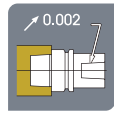

Run out accuracy  
內孔偏擺度



Surface hardness  
表面硬度

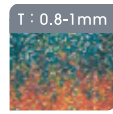

Carbonized depth  
滲碳深度

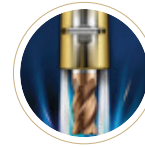

Order Code 訂購編號	Range(d) 夾持範圍	L	L1	D	D1	Min <sup>1</sup> G2.5 動態平衡	Spanner 扳手規格	Recommended Torsion 推薦鎖固扭力	Torque Wrench 扭力扳手
HSK100A-UC25-160	12-25	160	136	58	72	20,000	M10	25Nm	TW30+M10100

- The collet designed with PIN, 100% never tool pull out.
- Must be used R groove tool or standard specifications DIN 6535 HB for side lock tool.
- Must to choose the Pin collet, please check p.21

- 有PIN的夾頭設計，100%不掉刀。
- 必須使用R型溝槽刀具或標準規範DIN 6535 HB的側固刀具。
- 必須選用有PIN的筒夾，請參閱 p.21



CENTER COOLANT  
| 中心出水 |

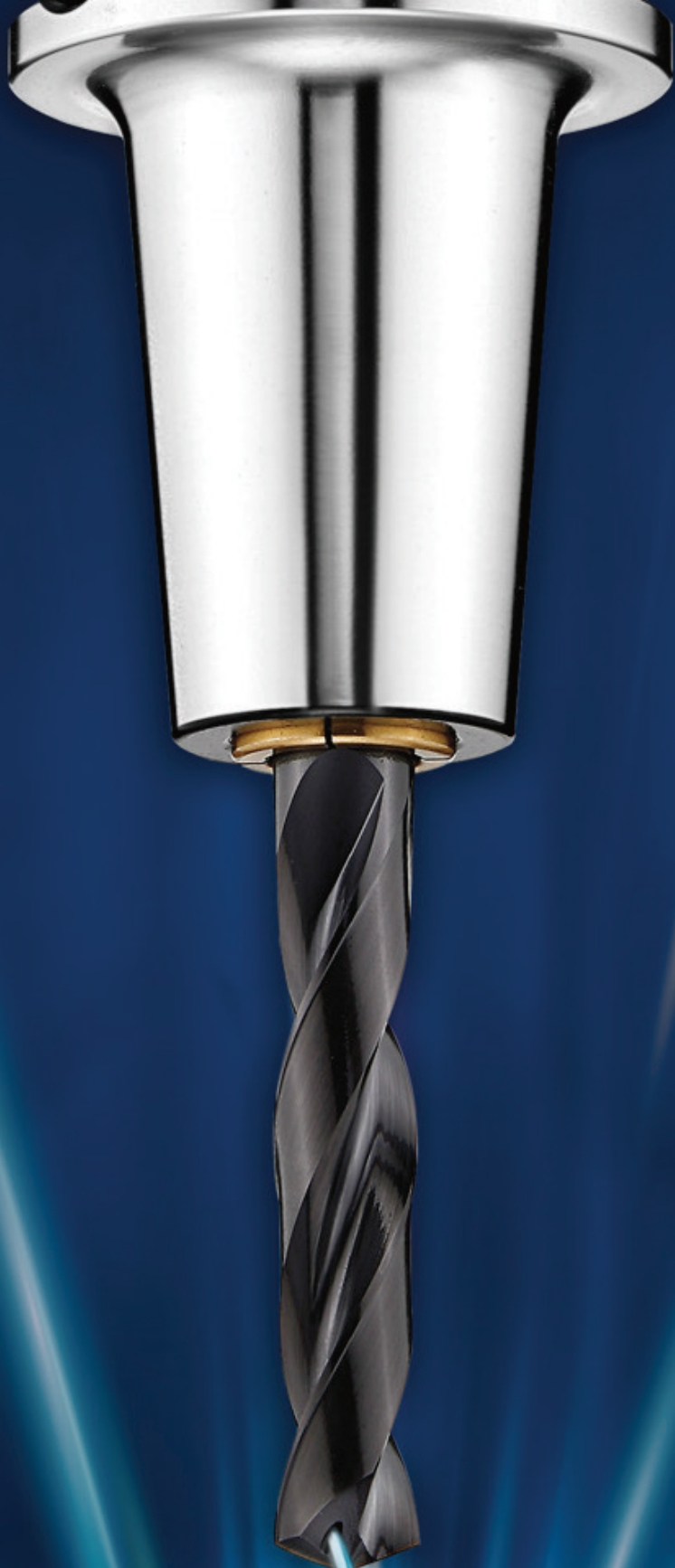

## UC GOLD CHUCK (UC6) Slim Long Type

UC 黃金夾頭刀柄 (UC6) 小徑加長型

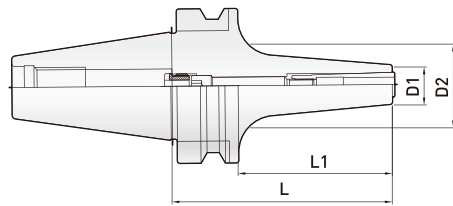
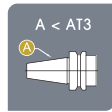
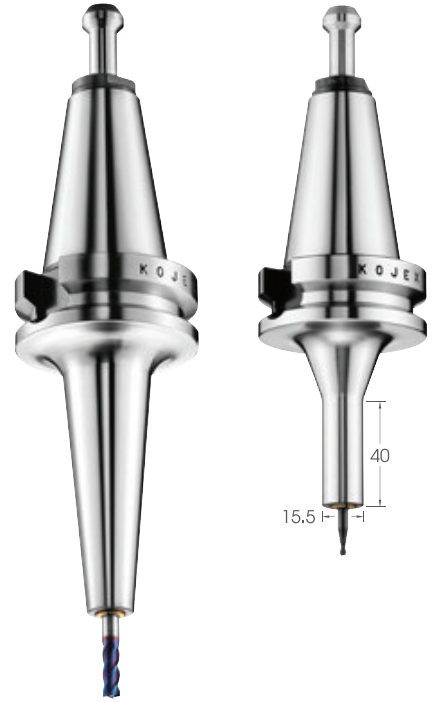
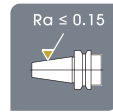

Fig 1 / 圖號 1

Fig 2 / 圖號 2



Taper tolerance  
錐度公差



Surface roughness  
表面粗度

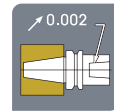

Run out accuracy  
內孔偏擺度



Surface hardness  
表面硬度

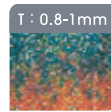

Carbonized depth  
滲碳深度

Order Code 訂購編號	L	L1	D1	D2	Fig 圖號	Min <sup>-1</sup> G2.5 動態平衡	Spanner 扳手規格	Recommended Torsion 推薦鎖固扭力	Fixed Torque Spanner 固定扭力扳手
BT30-UC6-70	70	48	16	24	1	30,000	M4	5Nm	30294-5144
UC6-90	90	68	16	29	1	30,000	M4	5Nm	30294-5144
UC6-120	120	98	16	33	1	30,000	M4	5Nm	30294-5144
BT40-UC6-90	90	63	16	27	1	30,000	M4	5Nm	30294-5144
UC6-90T	90	63	15.5	32	2	30,000	M4	5Nm	30294-5144
UC6-120	120	93	16	32	1	30,000	M4	5Nm	30294-5146
UC6-150	150	123	16	38	1	30,000	M4	5Nm	30294-5146

- Collet chuck designed without nut and with inner-holding collet. This has strong rigidity and high stability.
- Torque wrench is recommended for chuck stability.
- Torque wrench must be ordered separately.
- The recommended torsion and correct torque wrench prevents deformation of the tool holder.

- 沒有螺帽的後拉式夾頭設計，鋼性強穩定性高。
- 為求使用上的穩定性，建議使用扭力扳手。
- 扭力扳手必須另外訂購。
- 鎖固扭力不要超過推薦值的30%以上，過高的鎖固扭力，可能導致刀柄的變形。



# UC GOLD CHUCK (UC10)

## UC 黃金夾頭刀柄 (UC10)

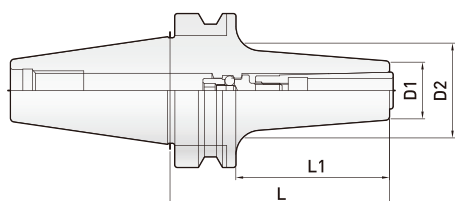
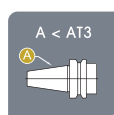

Fig 1 / 圖號 1



Fig 2 / 圖號 2



Taper tolerance  
錐度公差

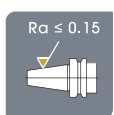

Surface roughness  
表面粗度

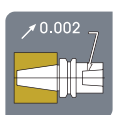

Run out accuracy  
內孔偏擺度



Surface hardness  
表面硬度

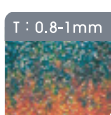

Carbonized depth  
滲碳深度

### Slim Long Type 小徑加長型

Order Code 訂購編號	L	L1	D1	D2	Fig 圖號	Min <sup>-1</sup> G2.5 動態平衡	Spanner 扳手規格	Recommended Torsion 推薦鎖固扭力	Fixed Torque Spanner 固定扭力扳手
BT30-UC10-70	70	48	24	32	1	30,000	M5	7Nm	30294-5152
BT40-UC10-90	90	63	24	35	1	30,000	M5	7Nm	30294-5154
UC10-120	120	93	24	40	1	30,000	M5	7Nm	30294-5156
UC10-150	150	123	24	46	1	30,000	M5	7Nm	30294-5156
BT50-UC10-110	110	72	24	36	1	20,000	M5	7Nm	30294-5156
UC10-150	150	112	24	43	1	20,000	M5	7Nm	30294-5158
UC10-200	200	162	24	52	1	20,000	M5	7Nm	30294-5159

### High Vibration Damping Type 高阻尼減震型

BT40-UC10-70	70	38	30	37.5	2	30,000	M5	7Nm	30294-5152
--------------	----	----	----	------	---	--------	----	-----	------------

- Collet chuck designed without nut and with inner-holding collet. This has strong rigidity and high stability.
- Torque wrench is recommended for chuck stability.
- Torque wrench must be ordered separately.
- The recommended torsion and correct torque wrench prevents deformation of the tool holder.

- 沒有螺帽的後拉式夾頭設計，鋼性強穩定性高。
- 為求使用上的穩定性，建議使用扭力扳手。
- 扭力扳手必須另外訂購。
- 鎖固扭力不要超過推薦值的30%以上，過高的鎖固扭力，可能導致刀柄的變形。





# UC GOLD CHUCK ( UC16 ) High Vibration Damping Type

UC 黃金夾頭刀柄 (UC16) 高阻尼減震型

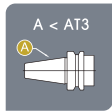
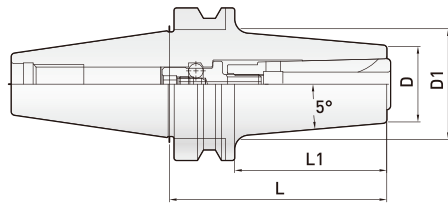

Taper tolerance  
錐度公差



Surface roughness  
表面粗度

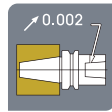

Run out accuracy  
內孔偏擺度

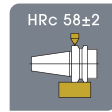

Surface hardness  
表面硬度

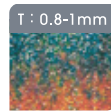

Carbonized depth  
滲碳深度

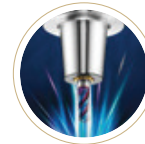
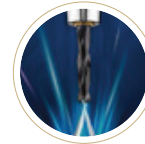

Order Code 訂購編號	L	L1	D	D1	Min-1G2.5 動態平衡	Spanner 扳手規格	Recommended Torsion 推薦鎖固扭力	Torque Wrench 扭力扳手	Center Coolant 中心出水	Side Coolant 側面出水	Pin Collet Pin筒夾
BT30-UC16-70	70	48	32	40	30,000	M6	15Nm	TW30+M06100	✓	✓	X
BT40-UC16-70	70	43	40	47	30,000	M6	15Nm	TW30+M06100	✓	✓	X
UC16-90	90	63	32	40	30,000	M6	15Nm	TW30+M06100	✓	✓	X
UC16-120	120	93	32	-	30,000	M6	15Nm	TW30+M06160	✓	✓	X
BT50-UC16-120	120	78	32	42	20,000	M6	15Nm	TW30+M06160	✓	✓	X
UC16-150	150	108	32	52	20,000	M6	15Nm	TW30+M06200	✓	✓	X

- Provide the center coolant and the side coolant.
- Select the side coolant must to use the collet with coolant slot, please check p.20
- Select the general collet for center coolant, please check p.19
- Coolant can be sprayed directly into the edge of tool for quick cooling and remove the steel chip.

- 可以選擇中心出水及側面出水的功能。
- 側面出水必須選用有水槽的夾頭，請參閱 p.20
- 中心出水選用一般的夾頭，請參閱 p.19
- 冷却液可直接噴到刀尖位置，可快速冷却及去除鐵屑。



# UC GOLD CHUCK ( UC20 ) High Vibration Damping Type

UC 黃金夾頭刀柄 (UC20) 高阻尼減震型

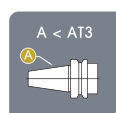
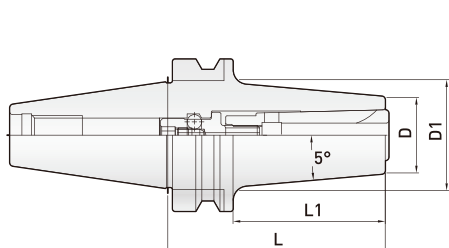

Taper tolerance  
錐度公差

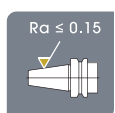

Surface roughness  
表面粗度

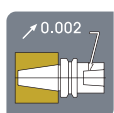

Run out accuracy  
內孔偏擺度



Surface hardness  
表面硬度

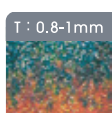

Carbonized depth  
滲碳深度

Order Code 訂購編號	L	L1	D	D1	Min <sup>-1</sup> G2.5 動態平衡	Spanner 扳手規格	Recommended Torsion 推薦鎖固扭力	Torque Wrench 扭力扳手	Center Coolant 中心出水	Side Coolant 側面出水	Pin Collet Pin筒夾
BT40-UC20-70	70	43	45	-	30,000	M8	20Nm	TW30+M08100	✓	✓	✓
BT50-UC20-100	100	62	45	58	20,000	M8	20Nm	TW30+M08160	✓	✓	✓
UC20-150	150	112	45	58	20,000	M8	20Nm	TW30+M08160	✓	✓	✓

- Provide the center coolant and the side coolant.
- Select the side coolant must to use the collet with coolant slot, please check p.20
- Select the general collet for center coolant, please check p.19
- Select the PIN Collet, please check p.21
- Coolant can be sprayed directly into the edge of tool for quick cooling and remove the steel chip.

- 可以選擇中心出水及側面出水的功能。
- 側面出水必須選用有水槽的夾頭，請參閱 p.20
- 中心出水選用一般的夾頭，請參閱 p.19
- 可以選用PIN Collet，請參閱 p.21
- 冷却液可直接噴到刀尖位置，可快速冷却及去除鐵屑。



# UC PIN COLLET CHUCK ( UC25 ) High Vibration Damping Type

UC 安卡夾頭 (UC25) 高阻尼減震型

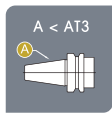
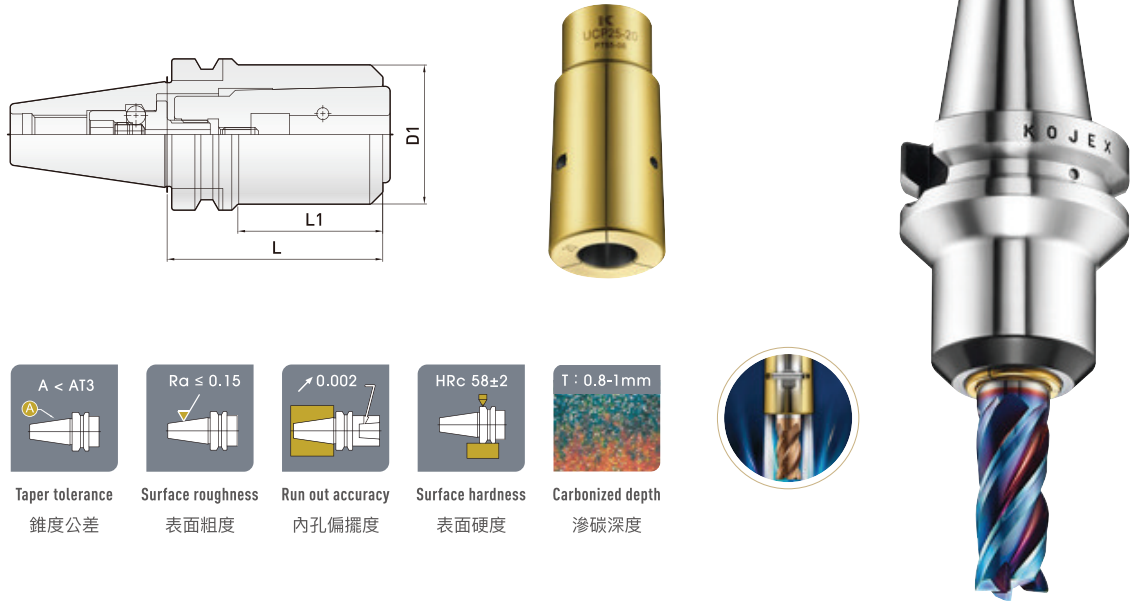

Taper tolerance  
錐度公差



Surface roughness  
表面粗度

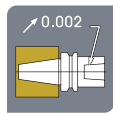

Run out accuracy  
內孔偏擺度



Surface hardness  
表面硬度

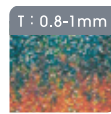

Carbonized depth  
滲碳深度



Order Code 訂購編號	L	L1	D1	D2	Min <sup>1</sup> G2.5 動態平衡	Spanner 扳手規格	Recommended Torsion 推薦鎖固扭力	Torque Wrench 扭力扳手
BT40-UC25-90	90	63	58	-	30,000	M10	25Nm	TW30+M10100
BT50-UC25-100	100	62	58	-	20,000	M10	25Nm	TW30+M10160
UC25-150	150	112	58	72	20,000	M10	25Nm	TW30+M10160

- The collet designed with PIN, 100% never tool pull out.
- Must be used R groove tool or standard specifications DIN 6535 HB for side lock tool.
- Must to choose the Pin collet, please check p.21
- 有PIN的夾頭設計，100%不掉刀。
- 必須使用R型溝槽刀具或標準規範DIN 6535 HB的側固刀具。
- 必須選用有PIN的筒夾，請參閱 p.21



— 側面出水 —  
SIDE COOLANT





## UC GOLD CHUCK (UC10) Slim Long Type

UC 黃金夾頭刀柄 (UC10) 小徑加長型

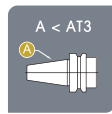
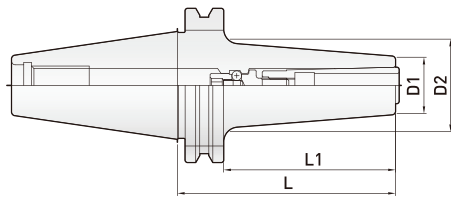

Taper tolerance  
錐度公差

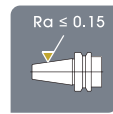

Surface roughness  
表面粗度

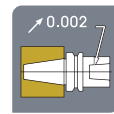

Run out accuracy  
內孔偏擺度



Surface hardness  
表面硬度

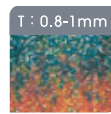

Carbonized depth  
滲碳深度

Order Code 訂購編號	L	L1	D1	D2	Min <sup>-1</sup> G6.3 動態平衡	Spanner 扳手規格	Recommended Torsion 推薦鎖固扭力	Fixed Torque Spanner 固定扭力扳手
SK40-UC10-90	90	71	24	36	20,000	M5	7Nm	30294-5154
UC10-120	120	101	24	41	20,000	M5	7Nm	30294-5156
UC10-150	150	131	24	47	20,000	M5	7Nm	30294-5156

- Collet chuck designed without nut and with inner-holding collet. This has strong rigidity and high stability.
- Torque wrench is recommended for chuck stability.
- Torque wrench must be ordered separately.
- The recommended torsion and correct torque wrench prevents deformation of the tool holder.

- 沒有螺帽的後拉式夾頭設計，鋼性強穩定性高。
- 為求使用上的穩定性，建議使用扭力扳手。
- 扭力扳手必須另外訂購。
- 鎖固扭力不要超過推薦值的30%以上，過高的鎖固扭力，可能導致刀柄的變形。



# UC GOLD CHUCK ( UC16 ) High Vibration Damping Type

UC 黃金夾頭刀柄 (UC16) 高阻尼減震型

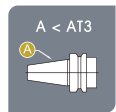
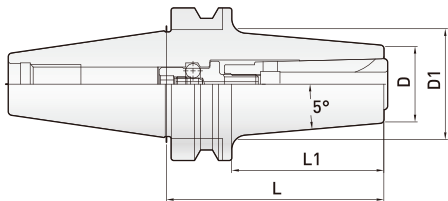

Taper tolerance  
錐度公差

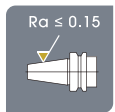

Surface roughness  
表面粗度

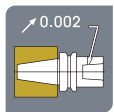

Run out accuracy  
內孔偏擺度



Surface hardness  
表面硬度

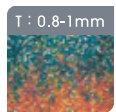

Carbonized depth  
滲碳深度

Order Code 訂購編號	L	L1	D	D1	Min <sup>-1</sup> G6.3 動態平衡	Spanner 扳手規格	Recommended Torsion 推薦鎖固扭力	Torque Wrench 扭力扳手	Center Coolant 中心出水	Side Coolant 側面出水	Pin Collet Pin筒夾
SK40-UC16-90	90	71	32	40	20,000	M6	15Nm	TW30+M06100	✓	✓	X

- Provide the center coolant and the side coolant.
- Select the side coolant must use the collet with coolant slot, please check p.20
- Select the general collet for center coolant, please check p.19
- Coolant can be sprayed directly into the edge of tool for quick cooling and remove the steel chip.

- 可以選擇中心出水及側面出水的功能。
- 側面出水必須選用有水槽的夾頭，請參閱 p.20
- 中心出水選用一般的夾頭，請參閱 p.19
- 冷却液可直接噴到刀尖位置，可快速冷却及去除鐵屑。



## UC GOLD CHUCK ( UC20 ) High Vibration Damping Type

UC 黃金夾頭刀柄 (UC20) 高阻尼減震型

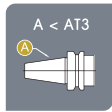
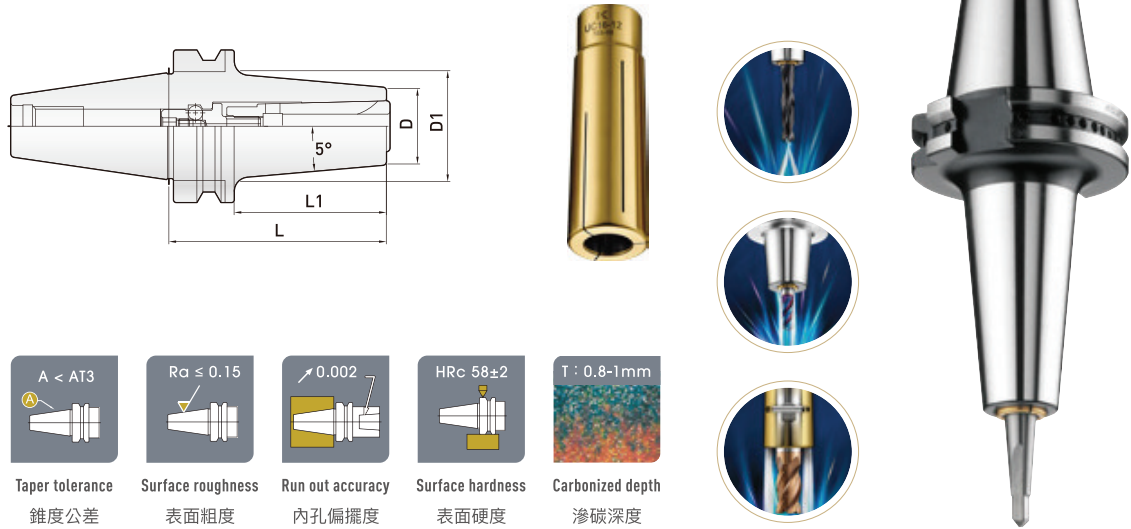

A < AT3

Taper tolerance  
錐度公差



Ra ≤ 0.15

Surface roughness  
表面粗度

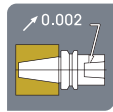

0.002

Run out accuracy  
內孔偏擺度



HRC 58±2

Surface hardness  
表面硬度

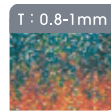

T: 0.8-1mm

Carbonized depth  
滲碳深度

Order Code 訂購編號	L	L1	D	D1	Min <sup>-1</sup> G6.3 動態平衡	Spanner 扳手規格	Recommended Torsion 推薦鎖固扭力	Torque Wrench 扭力扳手	Center Coolant 中心出水	Side Coolant 側面出水	Pin Collet Pin筒夾
SK40-UC20-70	70	43	45	-	20,000	M8	20Nm	TW30+M08100	✓	✓	✓

- Provide the center coolant and the side coolant.
- Select the side coolant must use the collet with coolant slot, please check p.20
- Select the general collet for center coolant, please check p.19
- Select the PIN Collet, please check p.21
- Coolant can be sprayed directly into the edge of tool for quick cooling and remove the steel chip.

- 可以選擇中心出水及側面出水的功能。
- 側面出水必須選用有水槽的夾頭，請參閱 p.20
- 中心出水選用一般的夾頭，請參閱 p.19
- 可以選用PIN Collet，請參閱 p.21
- 冷却液可直接噴到刀尖位置，可快速冷却及去除鐵屑。



# PIN COLLET COOLANT

— 安卡夾頭 —

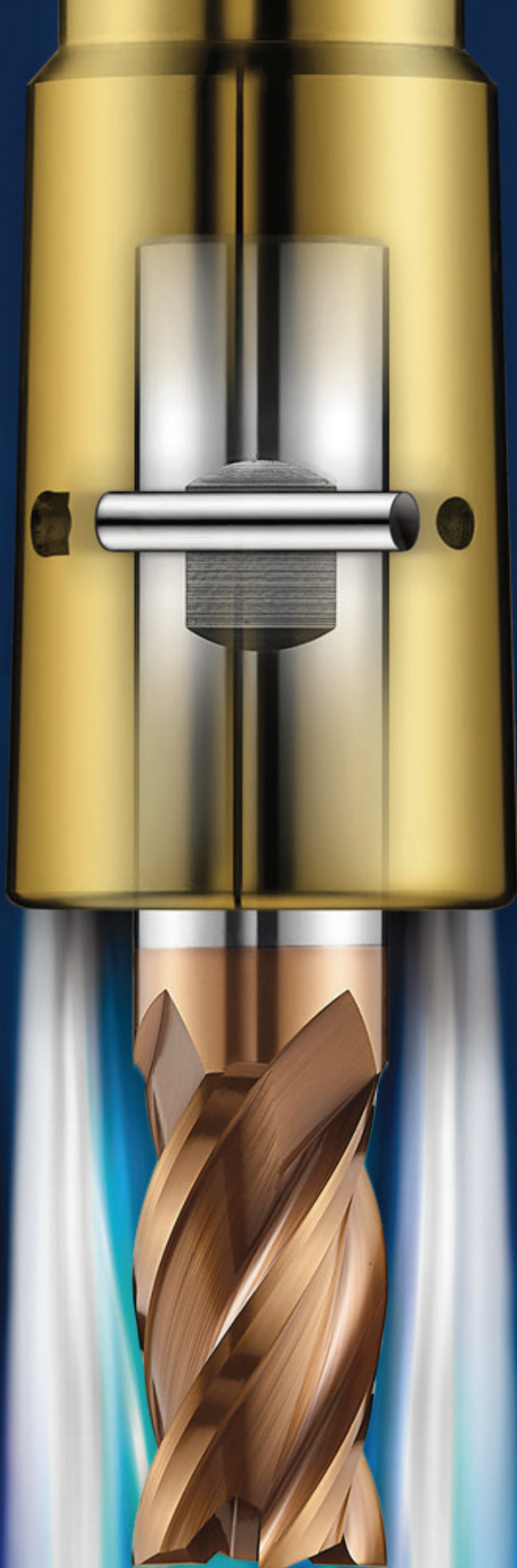



## UC COLLET

UC 黃金夾頭

- Runout <math>< 5\mu\text{m}</math> (4×D)
- 跳動精度 <math>< 5\mu\text{m}</math> (4×D)

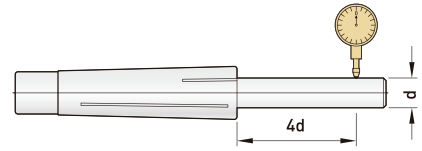

## UC 6

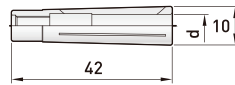

Order Code 訂購編號	(d) 夾持徑
UC6-3	3
4	4
5	5
6	6



## UC 10



Order Code 訂購編號	(d) 夾持徑
UC10-3	3
4	4
5	5
6	6
8	8
10	10



## UC 16 Center Coolant (中心出水)

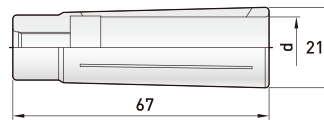

Order Code 訂購編號	(d) 夾持徑
UC16-6	6
8	8
10	10
12	12
14	14
16	16



## UC 20 Center Coolant (中心出水)

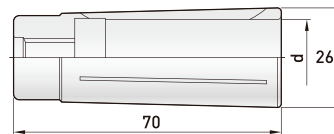

Order Code 訂購編號	(d) 夾持徑
UC20-6	6
8	8
10	10
12	12
16	16
20	20

## UC COLLET ( Side Coolant )

UC 黃金夾頭 (側邊出水)

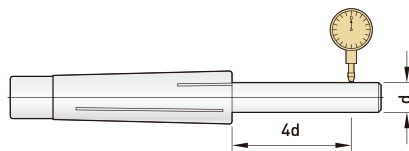

- Runout <math>< 5\mu\text{m}</math> (  $4 \times D$  )
- 跳動精度 <math>< 5\mu\text{m}</math> (  $4 \times D$  )

- Coolant can be sprayed directly into the edge of tool, for quick cooling and remove the steel chip.
- 冷却液可直接噴到刀尖位置，可快速冷却及去除鐵屑。

## UC 16F / UC 20F

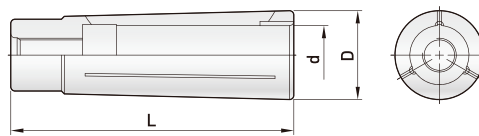

Order Code 訂購編號	(d) 夾持徑	L	D
UC16- 6F	6	67	21
8F	8		
10F	10		
12F	12		
14F	14		
16F	16		
UC20- 6F	6	70	26
8F	8		
10F	10		
12F	12		
16F	16		
20F	20		

# UC PIN COLLET

UC 安卡夾頭

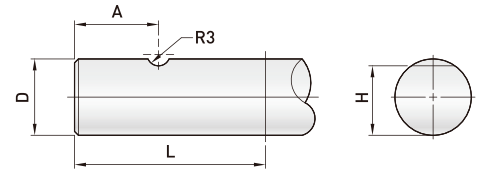
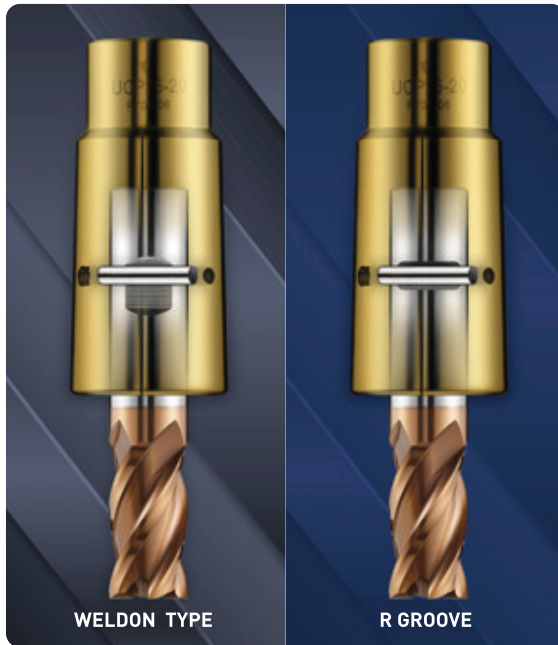

Tool shark Dia.				
D mm	L mm	A mm	H mm	R groove R 型溝槽
6	36	17 ± 2	4.8 <sup>0</sup> <sub>-0.4</sub>	R3
8	40	17 ± 2	6.6 <sup>0</sup> <sub>-0.4</sub>	
10	40	19 ± 2	8.4 <sup>0</sup> <sub>-0.4</sub>	
12	45	21 ± 2	10.4 <sup>0</sup> <sub>-0.4</sub>	
16	48	21 ± 2	14.2 <sup>0</sup> <sub>-0.4</sub>	
20	50	22 ± 2	18.2 <sup>0</sup> <sub>-0.4</sub>	
25	56	29 ± 2	23 <sup>0</sup> <sub>-0.4</sub>	

- Provide the Pin collet for UC20 and UC25. The tools can choose the standard side lock tool (DIN6535HB) or grinded the R groove at tools.
- UC PIN夾頭有UC20及UC25兩個系列可以選擇，刀具必須自行在柄部研磨R型溝槽或者選用標準側固的刀柄 (DIN6535HB)。

## UC 20P / UC 25P

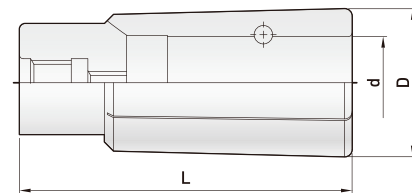
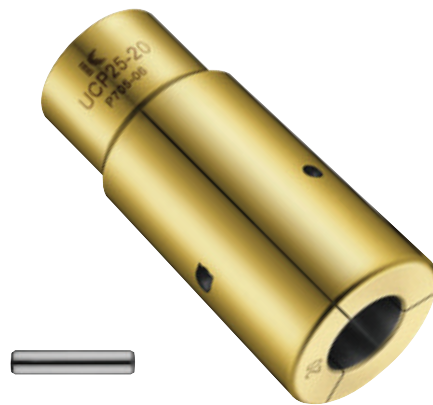

Order Code 訂購編號	(d) 夾持徑	L	D
UC20- 6P	6	70	26
8P	8		
10P	10		
12P	12		
16P	16		
UC25- 12P	12	90	40
16P	16		
20P	20		
25P	25		

## FIXED TORQUE SPANNER

固定扭力扳手



Order Code 訂購編號	Torque 扭力值	⊙	L	Tool Item 適用規格
30294-5144	5Nm	4	70	UC6
5146	5Nm	4	115	
5152	7Nm	5	55	UC10
5154	7Nm	5	90	
5156	7Nm	5	140	
5158	7Nm	5	180	
5159	7Nm	5	240	

## TORQUE WRENCH

扭力扳手



Order Code 訂購編號	Torque Nm 扭力值	Square Drive 接頭	Length (mm) 長度
TW30	5-30	3 / 8"	300



Order Code 訂購編號	⊙	Length (mm)	Tool Item 適用規格
M06100	6	100	UC16
M06160	6	160	UC16
M06200	6	200	UC16
M08100	8	100	UC20
M08160	8	160	UC20
M10100	10	100	UC25
M10160	10	160	UC25